

Functional
Safety
Type
Approved

www.tuv.com
ID 0600000000

Operating and assembly instructions

Incremental hollow shaft encoder with functional safety

FGH 41 in hollow shaft design

certified according to EN 61508 part 1-7:2010 / IEC 62061:2015 SIL CL2 and
EN ISO 13849-1: PL d

and according to EN 61508 Part 1-7:2010 / IEC62061:2015 SIL CL3 and
EN ISO 13849-1: PL e

**Read the operating and assembly instructions prior to
assembly, starting installation and handling!
Keep for future reference!**

Manufacturer / Publisher

Johannes Hübner

Fabrik elektrischer Maschinen GmbH

Siemensstr. 7

35394 Giessen / Germany

Phone: +49 641 7969 0

Fax: +49 641 73645

Internet: www.huebner-giessen.com

E-mail: info@huebner-giessen.com

Further current information on this product series can be found online in our Service Point.

Simply scan the QR Code and open the link in your browser.



Trademarks

Loctite® is a registered trademark of Henkel AG & Co. KG, Düsseldorf. Brand names and product names are trademarks or registered trademarks of their respective owner. Protected trademarks bearing a TM or ® symbol are not always depicted as such in the manual. However, the statutory rights of the respective owners remain unaffected.

Copyright

It is strictly forbidden to reproduce this publication or parts of this publication in any form or by any means without the prior written permission of Johannes Hübner Fabrik elektrischer Maschinen GmbH. Content information, text, drawings, graphics, and other representations are protected by copyright and are subject to commercial property rights. Duplications of any kind that are not combined with use of the machine are prohibited without manufacturer's written consent. Actions to the contrary make damage compensation mandatory.

Copyright© Johannes Hübner Fabrik elektrischer Maschinen GmbH

Change reservation

The manual has been drawn up with the utmost care and attention. Nevertheless, we cannot exclude the possibility of errors in form and content.

All rights, subject to errors and changes due to technical improvements reserved.

Font styles

Italic or **bold** font styles are used for the title of a document or are used for highlighting.

`Courier-New` font displays text, which is visible on the screen and software/software menu selections.

Contents

1 General Information.....	6
1.1 Applicability.....	6
1.2 Abbreviations and terms used.....	6
1.3 General functional description.....	7
1.3.1 Main Features.....	9
1.3.1.1 Variant 1 (FGH 41 SIN/COS).....	9
1.3.1.2 Variant 2 (FGH 41 TTL/HTL).....	9
1.3.2 Principle of the safety function.....	9
2 Basic safety instructions.....	10
2.1 Explanation of symbols and notes.....	10
2.2 General risks when using the product.....	11
2.3 Intended use.....	11
2.4 Non-intended use.....	12
2.5 Safety functions of the fail-safe processing unit.....	12
2.5.1 Mandatory safety checks / measures.....	13
2.6 Warranty and liability.....	14
2.7 Organizational measures.....	14
2.8 Personnel selection and qualification; basic obligations.....	14
2.9 Safety information.....	15
3 Transport, packaging and storage.....	16
3.1 Safety instructions for transport.....	16
3.2 Incoming goods inspection.....	16
3.3 Packaging / disposal.....	16
3.4 Storage of packages (devices).....	17
4 Technical Data.....	18
4.1 Safety.....	18
4.2 Electrical characteristics.....	19
4.2.1 General.....	19
4.2.2 Device-specific.....	20
4.3 Ambient conditions.....	21
4.4 Mechanical characteristics FGH 41.....	22
4.5 Type code.....	23
4.6 Type plate.....	23
5 Assembly.....	24
5.1 Safety instructions.....	24
5.2 Technical notes.....	25
5.3 Required tools.....	25
5.4 Mounting preparations.....	25
5.5 Mounting of FGH 41, (hollow shaft design).....	26
5.6 Dismantling the FGH 41.....	28
6 Installation / Preparation for Commissioning.....	29
6.1 Electrical connection Terminal box connection.....	29
6.2 EMC requirements.....	30
6.3 EMC conform wiring schemes.....	31
6.3.1 Connection scheme 1.....	31
6.3.2 Connection scheme 2.....	31
6.3.3 Connection scheme 3.....	32

6.4 Ground connection – measuring system	33
6.5 Cable specification	33
6.6 Permitted cable length.....	34
6.6.2 Square wave incremental-signals (TTL/HTL)	35
6.7 Connection instructions for plug connection	36
7 Incremental interface.....	36
7.1 Variant 1, analog incremental signals (SIN/COS)	37
7.2 Variant 2, square - wave incremental signals (TTL/HTL)	38
8 Connection diagram	39
9 Replacing the Measuring System	40
10 Checklist.....	41
11 Maintenance.....	42
12 Accessories	43
12.1 Draw-off-tool.....	43
12.2 Mating connector	43
13 Dimension drawings	44
13.1 FGH 41 T (hollow shaft design)	44
13.2 FGH 41 K (hollow shaft design)	45
13.3 FGH 41 K (with torque bracket)	46

1 General Information

These operating and assembly instructions contain the following topics:

- General functional description
- Basic safety instructions with declaration of the intended use
- Characteristics
- Assembly
- Installation/Commissioning
- Error causes and remedies

These operating and assembly instructions are supplemented by other documentation such as product data sheets, dimension drawings, connection diagrams, prospects, etc.

The scope of delivery includes the incremental hollow shaft encoder FGH 41 and the operating and assembly instructions.

The operating and assembly instructions may be requested separately.

1.1 Applicability

These operating and assembly instructions apply exclusively for the following measuring system series with **incremental-interface** and **functional safety**:

- FGH 41

The measuring system stands out due to 2 variants which are distinguished in the chapter “Main features” on page 9.

The products are labelled with affixed nameplates and are components of a system.

The following documentation therefore also applies:

- operator’s operating instructions specific to the system
- these operating and assembly instructions

1.2 Abbreviations and terms used

FGH 41	Incremental hollow shaft encoder
DCavg	D iagnostic C overage Average diagnostic coverage
ESD	E lectro S tatic D ischarge
EU	E uropean U nion
EMC	E lectro M agnetic C ompatibility
Functional safety (FS)	Part of the overall system safety, which depends on the correct functioning of safety-related systems for risk reduction. Functional safety is ensured when each safety function is executed as specified.
Fault exclusion	Compromise between the technical safety requirements and the theoretical possibility of an error occurring
HTL	H igh- T hreshold- L ogic
IEC	International Electrotechnical Commission
IEEE	I nstitute of E lectrical and E lectronics E ngineers
ISO	I nternational S tandard O rganisation
MTTFd	M ean T ime T o F ailure (d angerous) Mean time until dangerous failure

PFD _{av}	Average Probability of Failure on Demand Average probability of failure of a safety function with low demand
PFH	Probability of Failure per Hour Operating mode with high requirement rate or continuous demand. Probability of dangerous failure per hour.
PFH _D	Probability of a dangerous Failure per Hour Average probability of a dangerous failure per hour according to ISO 13849-1.
PL	Performance Level , according to ISO 13849-1: Discrete level, which specifies the capability of safety-related parts of a control to execute a safety function under foreseeable conditions.
SIL	Safety Integrity Level , according to IEC 62061: Four discrete levels (SIL1 to SIL4). The higher the SIL of a safety-related system, the lower the probability that the system cannot execute the required safety functions.
SIS	Safety Instrumented System : is used to protect a dangerous process and reduce the risk of an accident. Process instruments are a constituent of a Safety Instrumented System. This comprises the essential components of a complete safety-relevant process unit: Sensor, fail-safe processing unit (control) and actuator
SCS	Safety Computer System with control function
STP	Shielded Twisted Pair
TTL	Transistor-Transistor-Logik (RS422)
VDE	Verband der Elektrotechnik, Elektronik und Informationstechnik (Association for Electrical, Electronic and Information Technologies)
Repeat test (proof test)	Repetitive test to detect hidden dangerous failures in a safety-related system.

1.3 General functional description

The rotary measuring system FGH 41 is a safe and incremental position measuring system.

The measuring system has been designed so that it can be used in systems which require the following safety functions according to EN 61800-5-2:

- Safe Direction (SDI)
- Safe Stop 1 (SS1)
- Safe Stop 2 (SS2)
- Safe Operating Stop (SOS)
- Safely Limited Speed (SLS)
- Safe Speed Range (SSR)
- Safe Speed Monitor (SSM)
- Safely-Limited Acceleration (SLA)
- Safe Acceleration Range (SAR)
- Safely-Limited Position (SLP)
- Safely-Limited Increment (SLI)
- Safe Cam (SCA)

The measuring system as a sensor is always part of a safety chain.

The following shaft designs can be used for the mechanical coupling:

- Hollow shaft

Depending on the safety functions safety-related differences arise:

- SIL3/PLe/Kat.3,
in conjunction with velocity oriented safety functions

- SIL2/PLd/Kat.3,
in conjunction with positioning oriented safety functions

see chapter „**Fehler! Verweisquelle konnte nicht gefunden werden.**“ -> „functional safety“ on page 18.

1.3.1 Main Features

The entire system electronics has a discrete design. Neither microcontrollers nor programmable logic elements are contained in the system electronics. There is no interpolation or signal multiplexing. All signal lines are led separately within the electronics.

1.3.1.1 Variant 1 (FGH 41 SIN/COS)

Incremental interface with analog output signals SIN_{\pm} , COS_{\pm} and Ref_{\pm} ; output level 1 V_{ss}.

The safety-evaluated measuring system is designed for the implementation of safety-related functions in relation to speed and direction of rotation. In the downstream fail-safe processing unit an ideal error detection also occurs through evaluation of the annulus relationship " $SIN(x)^2 + COS(x)^2 = 1$ ".

The reference signals N , \bar{N} are not evaluated from a safety viewpoint and may not be used for safety-oriented purposes.

1.3.1.2 Variant 2 (FGH 41 TTL/HTL)

Incremental interface with digital square-wave output signals 0° , $\overline{0^{\circ}}$, 90° , $\overline{90^{\circ}}$ und N , \bar{N} , output level in TTL or HTL logic.

The safety-evaluated measuring system is designed for the implementation of safety-related functions in relation to speed and direction of rotation.

An internal signal monitor constantly checks the annulus relationship " $SIN(x)^2 + COS(x)^2 = 1$ ". Safety-relevant errors are indicated by switching of the signal outputs to tri-state. The reference signals N , \bar{N} are not evaluated from a safety viewpoint and may not be used for safety-oriented purposes.

1.3.2 Principle of the safety function

System safety results when:

- the scanning channel is single fault safe thanks to its own diagnostic measures and circuit measures
- the control checks that the received incremental data meet the expected tolerance window according to the application.
- for variant 1, the control also checks the annulus relationship $SIN(x)^2 + COS(x)^2 = 1$; if the result is outside the tolerance range, the incremental data must be evaluated as unsafe. In this way the control achieves an ideal error detection.
- when errors are detected the control introduces appropriate safety measures defined by the system manufacturer
- the system manufacturer ensures, through correct mounting of the measuring system, that the measuring system is always driven by the axis to be measured and is not overloaded. A fault exclusion is required for mounting the measuring system to the drive function.
- the system manufacturer carries out a proven test during commissioning
- the downstream fail-safe processing unit evaluates the measuring system differentially

2 Basic safety instructions

2.1 Explanation of symbols and notes

Warnings are indicated by symbols in these operating and assembly instructions. The warnings are introduced by signal words that express the scope of the hazard.

The warnings must be strictly heeded; you must act prudently to prevent accidents, personal injury, and property damage.



DANGER!

Means that death or serious injury will occur if the required precautions are not met.



WARNING!

Means that death or serious injury can occur if the required precautions are not met.



CAUTION!

Means that minor injuries can occur if the required precautions are not met.



NOTICE!

Indicates a possibly dangerous situation that can result in material damage if it is not avoided.



NOTES!

Indicates important information or features and application tips for the product used.



NOTES!

Means that appropriate ESD-protective measures are to be considered according to EN 61340-5-1 supplementary sheet 1.



NOTES!

Do not use a hammer or similar tool when installing the device due to the risk of damage occurring to the bearings or coupling!

2.2 General risks when using the product

The product, hereinafter referred to as *the measuring system*, is manufactured according to state-of-the-art technology and accepted safety rules. **Nevertheless, non-intended use can pose a danger to life and limb of the user or third parties, or lead to impairment of the measuring system or other property!**

Only use the measuring system in perfect technical condition, and only for its intended use, paying attention to safety and dangers, and in compliance with the **operating and assembly instructions!** Faults which could threaten safety should be eliminated without delay!

2.3 Intended use

The safety measuring system can be used for the detection of angular movement and processing of measured data for a downstream safety computer system in systems in which the **protection goals** of "**Protection of speed**" and "**Protection of direction of movement**" must be safely achieved. The complete processing chain of the safety function must then satisfy the requirements of the applied safety standard.

The safety measuring system may only be used in safety applications in conjunction with a control certified according to the applied safety standard.

The system manufacturer must check that the characteristics of the measuring system satisfy his application-specific safety requirements. The responsibility or decision regarding the use of the measuring system lies with the system manufacturer.

Intended use also includes:

- observing all instructions in this operating and assembly instructions,
- observing the nameplate and any prohibition or instruction symbols on the measuring system,
- observing the operating instructions from the machine/system manufacturer,
- operating the measuring system within the limit values specified in the technical data,
- ensuring that the fail-safe processing unit (F-Host) fulfils all required safety functions,
- observing and using the checklist in the Appendix,
- safe mounting (form-closed) of the measuring system to the driving axis, also see chapter "Assembly" from page 24.

2.4 Non-intended use



WARNING! NOTICE!

Danger of death, physical injury and damage to property in case of non-intended use of the measuring system!

The following areas of use are especially forbidden:

- in environments where there is an explosive atmosphere
- for medical purposes
- fastening transport or lifting tackle to the device
for example a crane hook to lift a motor
- fastening packaging components to the device
for example ratchet straps, tarpaulins etc.
- using the device as a step
for example by people to climb onto a motor

2.5 Safety functions of the fail-safe processing unit

The **Safety Computer System (SCS)**, to which the measuring system is connected, must perform the following safety checks.

With regard to "Single fault safety" and "Ideal error detection" please see IFA directive "GS-IFA-M21".



NOTES!

To enable the correct measures to be taken in the case of an error, the following applies:

- **Safe state – passive, only for measuring system variant 1**

In passive safe state the measuring system does not output any valid $SIN\pm/COS\pm$ – signals to the downstream fail-safe processing unit. The processing unit detects the error through evaluation of the annulus relationship $SIN(x)^2 + COS(x)^2 = 1$. If the result is outside the tolerance range, the incremental data are evaluated as unsafe. The downstream fail-safe processing unit has an ideal error detection.

- **Safe state – active, only for measuring system variant 2**

In active safe state the signal outputs are switched to tri-state. The processing unit detects the error via an implemented cable breakage detection.

2.5.1 Mandatory safety checks / measures

Measures for commissioning, changes	SCS error reaction
Check that the desired automation task is executed as required.	STOP
Check by the SCS	SCS error reaction
Check of incremental data according to the present automation task and safety function.	STOP
Two-channel monitoring of incremental outputs for cable breakage.	For tri-state state -> STOP
Only for variant 1 Evaluation of the condition $\text{SIN}(x)^2 + \text{COS}(x)^2 = 1$. The number of checks / revolution corresponds to the number of periods/revolution: 1024, 2048 or 4096 For the safety functions SDI, SS1, SS2, SOS, SSR, SSM an annulus monitoring with DC = 90 % is required. For the SLS safety function a two-channel evaluation of the frequency from (SIN/COS) with a DC of 90 % is required.	If outside tolerance -> STOP
Only for variant 2 A cable break detection is required for the evaluation of the square pulse signals. In the safe state, the output drivers are in tri-state (high-resistance state).	If a cable break is detected -> STOP
Only for variant 2 Evaluation of the incremental data in differential mode and verification with respect to antivalence, quadrature and against phase equivalence between channels A and B	If outside tolerance -> STOP

2.6 Warranty and liability

In principle the "General Terms and Conditions" of Johannes Hübner - Fabrik elektrischer Maschinen GmbH apply. These are available to the operator with the Order Confirmation or when the contract is concluded at the latest. Warranty and liability claims in the case of personal injury or damage to property are excluded if they result from one or more of the following causes:

- Non-observance of these operating and assembly instructions
- Non-intended use of the measuring system
- Improper assembly, installation and start-up of the measuring system
- Work carried out incorrectly on the measuring system
- Operation of the measuring system with technical defects
- Mechanical or electrical modifications to the measuring systems undertaken autonomously
- Repairs carried out autonomously
- Third party interference and Acts of God
- Deployment of non-qualified personnel
- Opening of the measuring system or modifying it

2.7 Organizational measures

- The operating and assembly instructions must always be kept ready-to-hand at the place of use of the measuring system.
- In addition to the operating and assembly instructions, generally valid legal and other binding regulations on accident prevention and environmental protection must be observed and communicated.
- The respective applicable national, local and system-specific provisions and requirements must be observed and communicated.
- The operator is obliged to inform personnel on special operating features and requirements.
- Prior to commencing work, personnel working with the measuring system must have read and understood the **chapter 2 "Basic safety instructions" on page 10**.
- The nameplate and any prohibition or instruction symbols applied on the measuring system must always be maintained in a legible state.
- Do not undertake any mechanical or electrical modifications to the measuring system, except for those expressly described in this operating and assembly instructions.
- Repairs may only be undertaken by the manufacturer or a center or person authorized by the manufacturer.

2.8 Personnel selection and qualification; basic obligations

- All work on the measuring system must only be carried out by qualified personnel.
- Qualified personnel includes persons, who, through their training, experience and instruction, as well as their knowledge of the relevant standards, provisions, accident prevention regulations and operating conditions, have been authorized by the persons responsible for the system to carry out the required work and are able to recognize and avoid potential hazards. They are capable of identifying and avoiding potential hazards.
- The definition of "qualified personnel" also includes an understanding of the standards VDE 0105-100 and IEC 364 (source: e.g. Beuth Verlag GmbH, VDE-Verlag GmbH).
- The responsibility for assembly, installation, commissioning and operation must be clearly defined. The obligation exists to provide supervision for trainee personnel.

2.9 Safety information



WARNING! NOTICE! NOTES!

Destruction, damage and malfunction of the measuring system!

- Only carry out wiring work or opening and closing of electrical connections with the system de-energized.
- Do not undertake any welding work if the measuring system is already wired or switched on.
- Falling below or exceeding the permissible operating temperature limit values must be prevented through an appropriate heating/cooling measure at the place of installation.
- The measuring system must be installed so that no direct moisture can affect the measuring system.
- Suitable aeration/ventilation and heating/cooling measures must be provided at the place of installation to prevent the temperature falling below the dew point (condensation).
- The power supply must be protected with a fuse suitable for the supply lead cross-section.
- Cables used must be suitable for the temperature range.
- A defective measuring system must not be operated.
- Make sure that the installation environment is protected from aggressive media (acids etc.).
- Avoid shocks (e.g. hammer blows) to the shaft during installation.
- The use of the devices as a step, etc. is not intended use.
- Opening the measuring system is forbidden.
- The type plate specifies the technical characteristics of the measuring system. If the type plate is no longer legible or if the type plate is completely missing, the measuring system must not be operated.
- In case of storage as well as in the operation of the measuring system unused connecting plugs have to be provided either with a mating connector or with a protective cap. The IP protection class is to be selected according to the requirements.

**NOTES!**

The measuring system contains components and assemblies susceptible to electrical discharge, which can be destroyed if incorrectly handled.

Touching the measuring system connection contacts with the fingers must be avoided or the relevant ESD protective measures must be applied.

**NOTES!****Disposal**

If disposal has to be undertaken after the lifespan of the device, the respective applicable country-specific regulations are to be observed.

3 Transport, packaging and storage**NOTES!****Shipping information**

- Do not drop the device or subject it to heavy impacts!
The device contains an optical system.
- Use only the original packaging.
Inappropriate packaging material may cause damage to the unit in transit.
- Storage temperature: -40 °C...+85 °C
- Store in a dry place.

3.1 Safety instructions for transport**NOTICE!**

Material damage caused by improper transport!

Observe the symbols and information on the packaging:

- Do not throw – risk of breakage
- Keep dry
- Do not expose to heat above 40°C or direct sunlight.

3.2 Incoming goods inspection

Check delivery immediately upon receipt for completeness and possible transport damage. Inform the forwarder directly on receipt of the goods about existing transport damages (prepare pictures for evidence).

3.3 Packaging (disposal)

The packaging is not taken back and must be disposed of in accordance with the respective statutory regulations and local guidelines.

3.4 Storage of packages (devices)



Keep dry

Keep packages dry and free from dust; protect from moisture



Protect against heat

Protect packages from heat above 40° C and direct sunlight

If you intend to store the device for a longer period of time (> 6 months) we recommend you use protective packaging (with desiccant).



NOTES!

Turn the shaft of the device every 6 month to prevent the bearing grease solidifying!

4 Technical Data

4.1 Safety

Functional safety	
EN 61508 Part 1-7	Safety Integrity Level (SIL)
⁽¹⁾ SDI, SS1, SS2, SOS, SLP, SLI, SCA	-2
⁽¹⁾ SLS, SSR, SSM, SLA, SAR	-3
EN ISO 13849-1	Performance Level (PL)
⁽¹⁾ SDI, SS1, SS2, SOS, SLP, SLI, SCA	- PLd / Kat. 3
⁽¹⁾ SLS, SSR, SSM, SLA, SAR	- PLe / Kat. 3
Startup time	Time between POWER-UP and safe incremental output
Variant 1	≤ 30 ms
Variant 2	≤ 50 ms
PFH / PFHD, "High demand" operating mode	
Variant 1	5,34 * 10 ⁻⁹ 1/h
Variant 2	6,57 * 10 ⁻⁹ 1/h
Notice	Measuring system is used only in applications with high or continuous demand rate
MTTF_d	high
Variant 1	1558 a
Variant 2	622 a
⁽²⁾ DC_{avg}	Medium (90 %)
Internal process safety time	Time between occurrence of an F-Error and alarm indication
Overall system	≤ 1 ms
Process safety angle	Angle between error occurrence and alarm indication
Through channel-internal self-diagnosis	± 0.3510°, at 1024 periods; ± 0.1760°, at 2048 periods; ± 0.0879°, at 4096 periods; in relation to the measuring system shaft
T₁ repeat test (proof test)	20 years

⁽¹⁾ according to EN 61800-5-2

⁽²⁾ The assessment occurred in accordance with Note 2 on Table 6 of EN ISO 13849-1

4.2 Electrical characteristics

4.2.1 General

Supply voltage	12...30 V DC acc. to IEC 60364-4-41, SELV/PELV
Reverse polarity protection	Yes
Short-circuit protection	Yes, by internal 1 A safety fuse
Overvoltage protection	Yes, up to ≤ 60 V DC
Current consumption without load	at 24 V DC
Analog output signals	< 20 mA
Square-wave output signals	< 40 mA

4.2.2 Device-specific

Accuracy	
Usable resolution	10 bit, 11 bit, 12 bit; depending on the device configuration
Safety-related	+ 2 bit interpolated
Functional	+ 8 bit interpolated
Variant 1	
Incremental analog output signals	
Periods / revolution	1024, 2048, 4096 acc. to device variant
Incremental signals	SIN, $\overline{\text{SIN}}$, COS, $\overline{\text{COS}}$
Track position, electrical	90 °
Reference signals	N, $\overline{\text{N}}$, once per revolution
Output level	1 V _{SS} ± 0.2 V at 100 Ω, differential
Output current	20 mA
Output frequency	≤ 500 KHz
Short-circuit proof	Yes
Cable specification	see page 33
Variant 2	
Pulses / revolution	1024, 2048, 4096 acc. to device variant
Incremental signals	0°, $\overline{0^\circ}$, 90°, $\overline{90^\circ}$
Track position, electrical	90 °
Zero pulse	N, $\overline{\text{N}}$, once per revolution
Output level TTL	EIA standard RS422 (2-wire)
Output level HTL	Push-pull, supply voltage
Output current	50 mA, per channel
Output frequency	≤ 100 KHz
Short-circuit proof	Yes
Cable specification	see page 33

4.3 Ambient conditions

Vibration	
EN 60068-2-6	≤ 100 m/s ² , sine 55-500 Hz
Shock	
EN 60068-2-27	≤ 1000 m/s ² , half-sine 11 ms
EMC	
Immunity to disturbance	EN 61000-6-2
Transient emissions	EN 61000-6-3
Working temperature	
Derating hollow shaft, 3000 rpm	$T_a = 85 - (0,008 * n)$ in °C n = speed in rpm
Storage temperature	
	-40 °C...+85 °C, dry
Relative air humidity, EN 60068-3-4	
	98 %, non-condensing
Degree of protection EN 60529 (valid with screwed-on mating connectors or blind plugs and captive screw plug NDE)	
	IP66
Corrosion resistance	
	Seawater resistant

4.4 Mechanical characteristics FGH 41

Mechanically permissible speed	
– Degree of protection IP66	≤ 3000 rpm
– Note	Observe derating for permissible working temperature
Electrically permissible speed	
nelectric [rpm] = (output frequency [Hz] / no. of pulses per rev.) * 60 rpm	
Shaft load axial/radial	
Shaft load, axial/radial	Own mass
Bearing life time	≥ 3,9 * 10 ¹⁰ revolutions (*)
Permissible angular acceleration	≤ 10 ⁴ rad/s ²
Moment of inertia	
Degree of protection IP66	approx. 1870 gcm ²
Breakaway torque	
Degree of protection IP66	4.0 Ncm
Mass	approx. 3.1 kg

4.5 Type code

FGH 41	FG	41	G-90G-NG	/
Incremental encoder				
Construction type				
H = hollow shaft				
Series				
Connections				
T = 12-pole round plug M23				
K = Terminal strip in terminal box				
Pulses per rotation				
1024, 2048, 4096				
Signalamplitude				
H = HTL				
T = TTL				
S = Sin/Cos				
Signal-output				
= Basic version 0°, 90°, each with inverted signals (zero pulse not safety certified)				
Shaft with feather key				
20 P = hollow shaft Ø 20 H7 mm				

4.6 Type plate

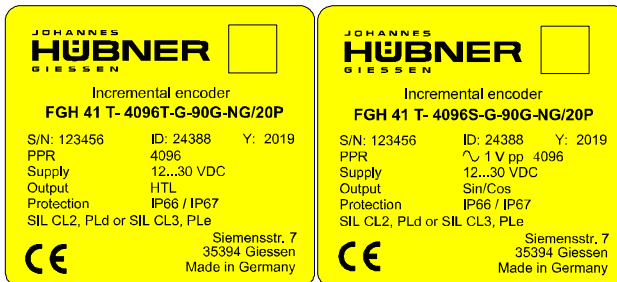

The type plate is located on the outside of the housing and contains the following information:

General information

Manufacturer, Address, CE marking
Type
Serial number (S/N)
Date of manufacturing
Order number (ID)
Supply voltage
Certification
QR-Code

Incremental encoder

Degree of protection IP
Pulse rate
Outputs
Signal level

5 Assembly

5.1 Safety instructions



WARNING!

At assembly, dismantling and other work to the device the basic safety instructions to chapter 2 must be observed.

The assembly, dismantling and other work of the measuring system must only be carried out by qualified personnel!



DANGER! NOTICE!

Danger of death, serious physical injury and/or damage to property due to deactivation of safety functions, caused by an unstable shaft drive!

- The system manufacturer must implement suitable design measures, so that the drive of the measuring system is ensured at all times through the shaft and mounting of the measuring system (fault exclusion). The specifications of **DIN EN 61800-5-2:2017-11** Adjustable speed electrical power drive systems, Safety requirements, Table D.8 – Motion and position sensors" must be observed.
- In general, the requirements and acceptance conditions for the complete system must be taken into account for mounting.
- The measuring system must be inspected on a regular basis (see below). Inspections must be recorded in a log book.

As the installation situation is application-dependent, the following notes are not exhaustive.

- All fastening screws must be secured against unintentional loosening. All screwed connections must be inspected once a year.
- In case of applications with low operating temperatures, increased values for the start-up torque result. This fact is to be considered when the assembling and shaft drive is performed.
- After approx. 16 000 - 20 000 hours of operation or higher levels of continuous load:
Check deep groove ball bearings for noise, running smoothly. Bearings must be replaced by the manufacturer only.
- **FGH 41(hollow shaft version):**
- the measuring system must be installed on a grease-free shaft by means of form-closure, using a parallel key/groove combination,
- Axial slipping of the measuring system on the drive shaft must be prevented through fixing by means of the axial tensioning disc.
- The torque bracket must be inspected once a year:
check link heads can move freely. You must be able to move the link rod manually. If it proves difficult to move, lightly oil the link rod heads or apply lubricant spray.

5.2 Technical notes



NOTES!

The use of a hammer or similar tool during assembly, disassembly and other work on the device is not permitted due to the risk of damage to ball bearings and coupling!

Ambient temperature

The max. permissible ambient temperature depends on the speed and degree of protection of the device and the place of installation.

Degree of protection

The device complies with the specified degree of protection (see chapter 4.3 "Ambient conditions" on page 21) only with screwed-on mating connectors or blind plugs!

Deep groove ball bearings

Incremental hollow shaft encoders FGH 41 are fitted with maintenance-free, greased "for-life" deep groove bearings. Bearings must be changed by the manufacturer only.

Opening the encoder renders the guarantee null and void.

Screw retention

All fastening screws must be secured against unintentional loosening. We recommend using Loctite® 243 (thread locker medium strength).

5.3 Required tools

- Spanners: 10, 13, 14, 24 mm, Allen key: 5 mm
- Flat-blade screwdriver, assembly grease, Loctite® 243 (medium strength thread locker)

5.4 Mounting preparations

Ensure all accessories are available.



NOTES!

Fastening screws and earth cable are not included in the scope of delivery.

- Preparing the place of attachment: Clean the (motor) shaft, centering, bolting surfaces and fastening threads; check for damage. Repair any damage!

5.5 Mounting of FGH 41, (hollow shaft design)

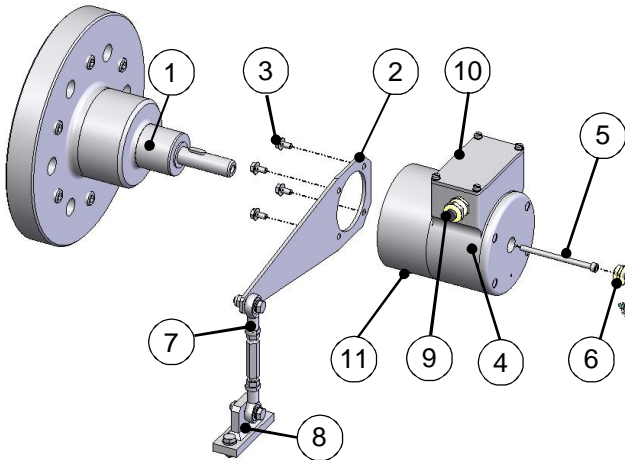

41 (mounting example)

Fig. 1: FGH

1. Mount the adapter shaft (1) and align using a dial gauge.



NOTES!

The maximum radial run-out of the adapter shaft is 0.05 mm.
If necessary, use the ball thrust adjustment screws to align the adapter shaft. Secure ball thrust screws with Loctite® 243. Remove unused ball thrust screws or secure with Loctite® 243. Max. tightening torque for M12 approx. 25 Nm, for M16 approx. 35 Nm. Use parallel keys to DIN 6885.
Observe the installation instructions supplied with the adapter shaft when installing!

2. Secure the torque bracket (2) to the hollow shaft encoder (4) using the 4 supplied Tensilock screws (3)! Tightening torque: 16 Nm.



NOTES!

When fitting the device, it is possible to align the torque bracket (2) in four different directions.

3. Mount the hollow shaft device (4) to the adapter shaft (1).



NOTES!

The hollow shaft device must slide easily onto the adapter shaft. Never use excessive force; otherwise the bearings may be damaged. If necessary, use emery cloth or a file to rework the adapter shaft and the feather key. Do not allow the device to hit hard against the collar of the shaft.

4. Secure the hollow-shaft device with the aid of the supplied hexagon socket head cap screw (5) (property class: 8.8)!



NOTES!

The hexagon head socket cap screws(5) are coated with a microencapsulated adhesive as locking agent.

5. Close hollow shaft device with captive screw plug (6).
6. Fastening the torque bracket:

Fastening without base plate:

Secure the link rod head of the link rod (7) to a fixed point (for example on the motor housing).

Fastening with base plate:

Secure the base plate (8) to a fixed point with two hexagon head screws (for example on the motor housing or the foundations).



HINWEIS!

Once fitted the link rod must rotate easily around the link rod heads! Failure to observe this point may result in damage to the bearings!

The perfect angle from the torque bracket (2) to the link rod (7) should be 90°.

The link heads are maintenance free. However, ensure they remain free from soiling and paint!

5.6 Dismantling the FGH 41



WARNING!

At assembly, dismantling and other work to the device the basic safety instructions to chapter 2 must be observed. The assembly, dismantling and other work on the device may only be carried out by qualified personnel.



NOTES!

To dismantle the hollow-shaft encoder, use the draw-off-tool ZS-109649 (available as an accessory) if you are unable to remove the device manually from the adapter shaft, after having removed the axial tensioning disc!

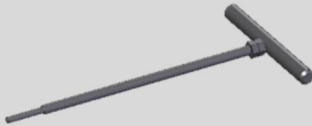

Draw-off-tool ZS-109649

Using the draw-off-tool, which is screwed into the withdrawal thread M7 of the hollow shaft, allows you to remove the hollow-shaft encoder from the adapter shaft without risking damage to the bearings.

6 Installation / Preparation for Commissioning

6.1 Electrical connection Terminal box connection

1. Open the terminal box cover (10) (see Fig. 1).



CAUTION!

Do not allow moisture to enter the terminal box when the cover is open!

2. Remove the cap of the cable gland (9) (see Fig.1).
3. Feed the cable into the terminal box through the cable gland.



NOTES!

The signal cable shielding can be connected directly to the housing via the EMC cable gland. A coil spring integrated in the cable gland ensures all-round contact is made with the bare cable shielding to ensure a good shield connection. This type of shield connection should be preferred.

To achieve an effective shielding the cable shield must also be connected in the electrical cabinet! It must be ensured that no potential equalization currents flow via the shield.

4. Tighten the cable gland and blanking plugs using a spanner.



NOTES!

Prior to delivery cable glands and blanking plugs are tightened finger tight only. To ensure that the terminal box is reliably sealed tighten all cable glands and blanking plugs before starting up for the first time.

5. Use a spanner to tighten the cable gland until the cable is securely clamped and properly sealed.



NOTES!

Prevent lateral pulling forces acting on the cable and plugs so as not to impair the degree of protection of the cable gland.

6. Strip cable insulation, crimp wire-end ferrules.
7. Connect the supply voltage and signal cable (see. connection diagrams, chapter 8).
8. Close the terminal box cover.



NOTES!

Before closing the terminal box cover check the sealing surface is clean and that the seal is in a good condition; clean or replace damaged seals as necessary.



CAUTION!

Ensure when closing the terminal box cover that no cable becomes jammed.

9. Attach the earth cable to the earth terminal (11) (see Fig. 1).

6.2 EMC requirements



WARNING!

Deactivation of the safety function due to radiated or conducted interference sources!

- Radiated interference sources due to radiophones, lightning strikes in networks, mobile phones and emissions from individual devices can cause malfunctions in the measuring system.
- Conducted interference sources in particular, such as frequency-controlled drives (system perturbations), have a negative effect on the function of the measuring system.
- The 24 V power supplies used must fulfil the requirements according to IEC 60364-4-41 SELV/PELV.
- The shielding effect of cables must also be guaranteed after installation (bending radii!) and after connector changes. In cases of doubt, use more flexible and more reliable cables.
- A 5-wire cable with a PE-conductor isolated from the N conductor (so-called TN network) is recommended for the drive/motor cabling. This will largely prevent equipotential bonding currents and the development of interference.
- A shielded and stranded data cable must be used to ensure high electromagnetic interference stability of the system. The shielding should be connected with low resistance to protective ground using large shield clips at both ends. The shielding should be grounded in the switch cabinet only if the machine ground is heavily contaminated with interference towards the switch cabinet ground.
- Equipotential bonding measures must be provided for the complete processing chain of the system. Compensating currents due to potential differences across the shield to the measuring system must be avoided in particular.
- Power and signal cables must be laid separately. During installation observe the national safety and installation guidelines for data and energy cables.
- Observe the manufacturer's instructions for the installation of converters and for shielding power cables between frequency converter and motor.
- Ensure adequate dimensioning of the energy supply.
- Separation or delimitation of the measuring system from potential jammers.
- Provide the use of filters.
- Observe requirements for external and internal lightning protection.
- To ensure safe and fault-free operation, the pertinent standards and directives must be observed. In particular, the applicable EMC directive and the shielding and grounding directives must be observed!

Upon completion of installation, a visual inspection with report should be carried out.

6.3 EMC conform wiring schemes

6.3.1 Connection scheme 1

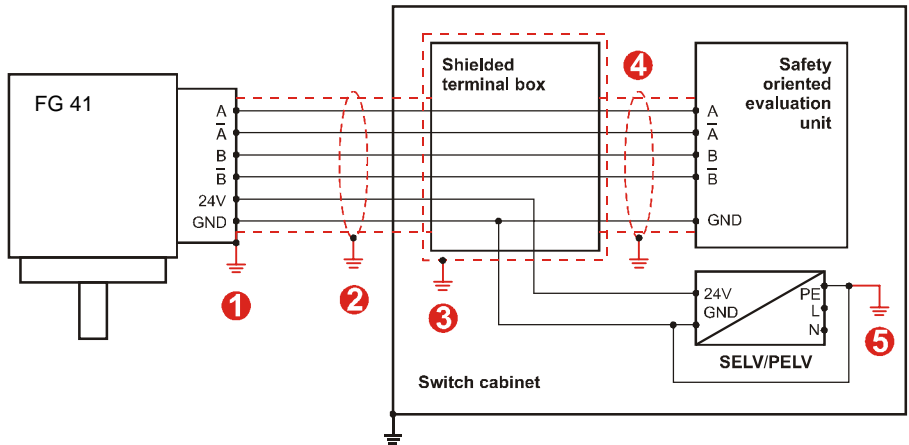

- 1x Ground connection (connection possibilities ①, ②, ③, ④ or ⑤)
- Avoid ground loops
- Connect all shields double-sided
- Shielding must not be interrupted
- Twisted pair wires (A, \bar{A}), (B, \bar{B})

6.3.2 Connection scheme 2

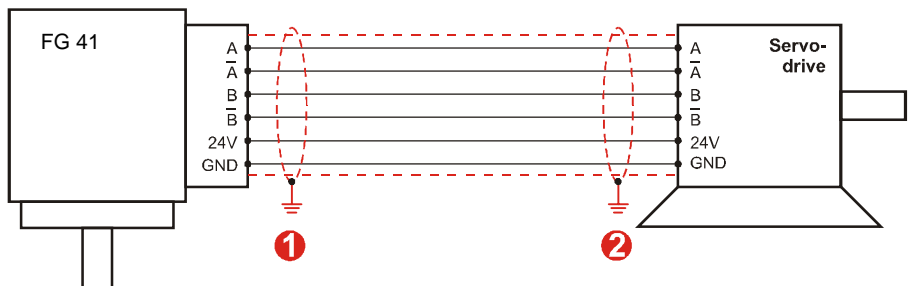

- 1x Ground connection (connection possibilities ① or ②)
- Avoid ground loops
- Connect all shields double-sided
- Shielding must not be interrupted
- Twisted pair wires (A, \bar{A}), (B, \bar{B})

6.3.3 Connection scheme 3

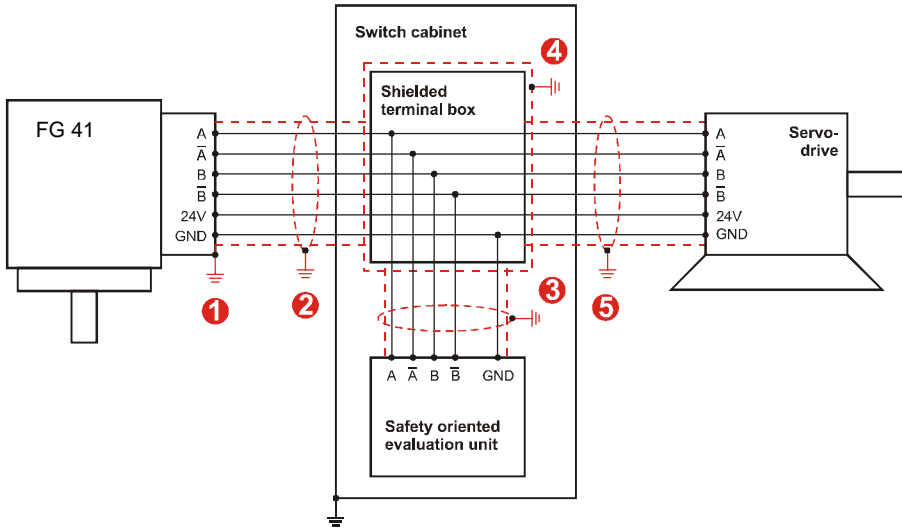

- 1x Ground connection (connection possibilities **1**, **2**, **3**, **4** or **5**)
- Avoid ground loops
- Connect all shields double-sided
- Shielding must not be interrupted
- Twisted pair wires (A/ \bar{A}), (B/ \bar{B})

6.4 Ground connection – measuring system

In principle, it is recommended that the ground connection of the measuring system has a good conductive connection to the functional earth of the machine.

(Cable with min. 4 mm²). An earthing terminal is provided on the measuring system for this purpose see dimension drawing HM 18 M 113294a.

6.5 Cable specification

Variant 1, analog incremental signals (SIN/COS)

Signal	Description
Supply	Min. 0.34 mm ² and shielded, 0.5 mm ² recommended. Generally the cable cross-section must be matched to the cable length.
SIN, $\overline{\text{SIN}}$	Min. 0.14 mm ² and shielded, 0.25 mm ² recommended. However, to ensure the signal quality and to minimize possible environmental influences, we recommend twisting each signal pair (\pm).
COS, $\overline{\text{COS}}$	
(*) N, \overline{N}	

Variant 2, square-wave incremental signals (TTL/HTL)

Signal	Beschreibung
Supply	Min. 0.34 mm ² and shielded, 0.5 mm ² recommended. Generally the cable cross-section must be matched to the cable length.
0°, $\overline{0^\circ}$	Min. 0.14 mm ² and shielded, 0.25 mm ² recommended. However, to ensure the signal quality and to minimize possible environmental influences, we recommend twisting each signal pair (\pm).
90°, $\overline{90^\circ}$	
(*) N, \overline{N}	

(*) optional, the reference signal is not evaluated from a safety viewpoint

6.6 Permitted cable length

The permissible cable length at the transmission of incremental signals depends on the output frequency, the applied supply voltage and the ambient temperature of the measuring system, see the following diagrams.

6.6.1 Analog incremental-signals (SIN/COS)

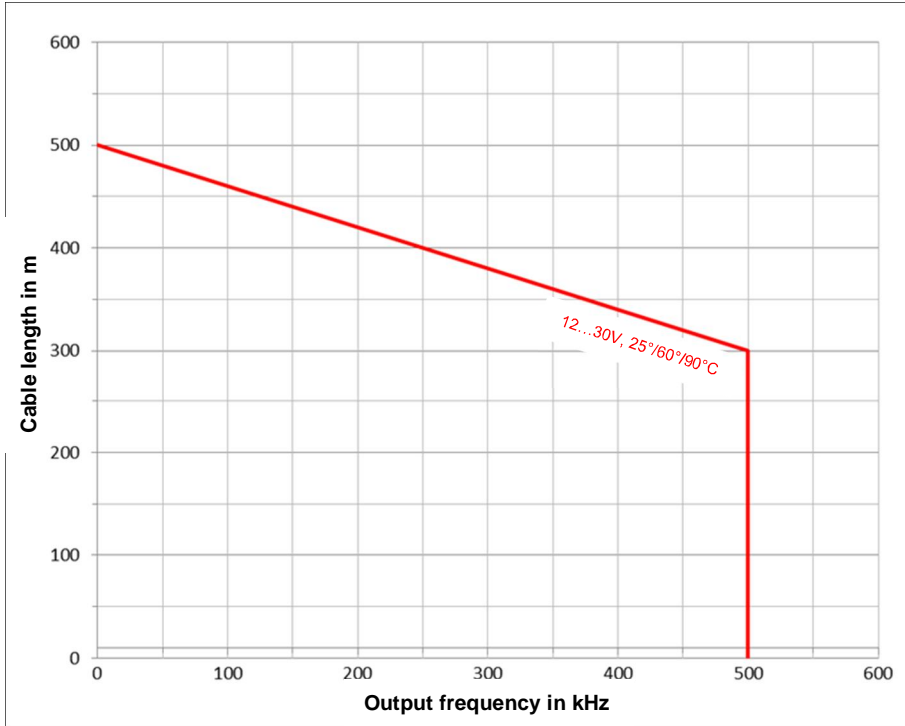

Fig. 1: Maximum permissible cable length for SIN/COS interface

6.6.2 Square wave incremental-signals (TTL/HTL)

TTL-Interface:

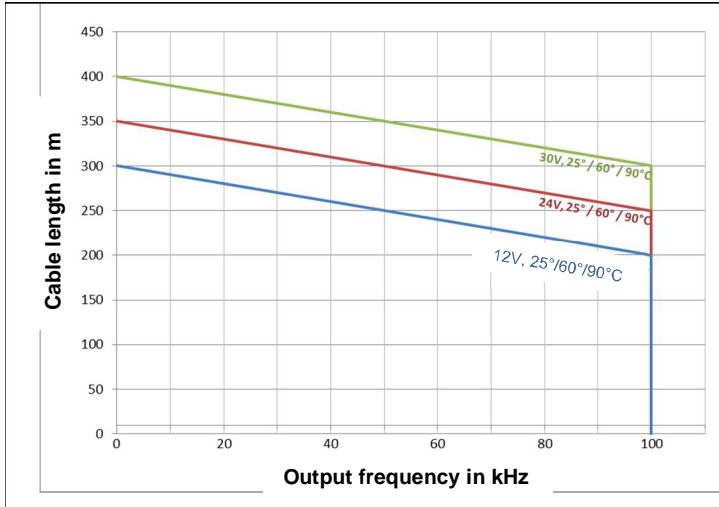

Fig. 2: Maximum permissible cable length for TTL interface

HTL-Interface:

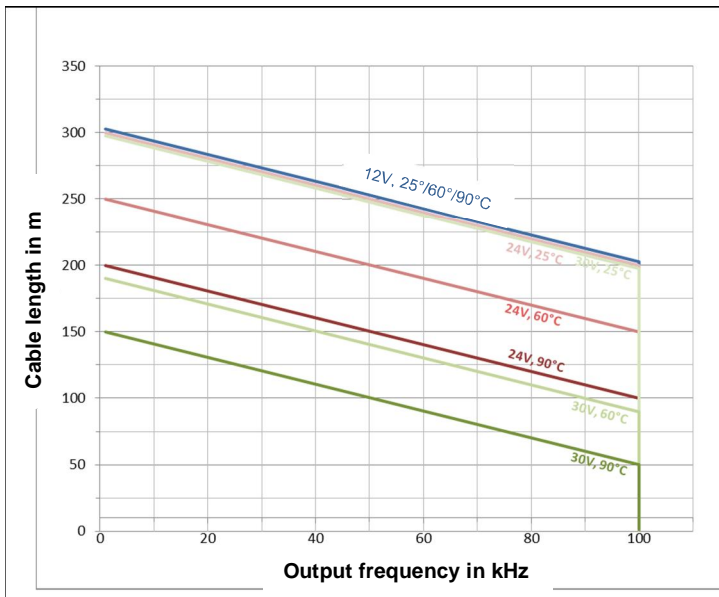

Fig. 3: Maximum permissible cable length for HTL interface

6.7 Connection instructions for plug connection

The electrical equipment features are mainly determined by the variable connection technology.



NOTES!

The connection can only be made in conjunction with the device-specific pin assignment!

When the measuring system is delivered, a printed version of the pin assignment is enclosed and can also be downloaded later.

7 Incremental interface



CAUTION!

Danger of damage to subsequent electronics due to overvoltages caused by a missing ground reference point!

- If the ground reference point is completely missing, e.g. 0 V of the power supply not connected, voltages equal to the supply voltage can occur at the outputs of this interface.
 - It must be ensured that a ground reference point is present at all times,
 - or the system operator must provide appropriate protective mechanisms for the subsequent electronics.
- If the input voltage exceeds 30 V, these voltages occur accordingly at the HTL outputs. This can lead to damage of the output or input circuit of the downstream processing unit.

The measuring system acquires the angular information from the connected process via the rotation of the shaft. A pulse disk is fixed to the shaft; this acquires the angular increments with a defined number of periods per revolution. A scanning unit with integrated optoelectronics generates electrical signals and outputs signal periods, which can be processed in a signal conditioner afterwards.

The resolution of the measuring system is defined by the number of light/dark segments (pulse number per revolution) on the pulse disk. A signal sequence of e.g. 1024 periods is output during one revolution. To evaluate the counting direction, a 2nd signal sequence with a 90° phase offset is output for the control.

The counter of an external control can be reset with an additional zero pulse, and the mechanics - control reference point can thus be defined.

7.1 Variant 1, analog incremental signals (SIN/COS)

The number of periods / revolution is dependent on the device variant. Resolutions of 1024, 2048 and 4096 periods / revolution are supported.

Measuring the signals against 0 V gives the following signal curve:

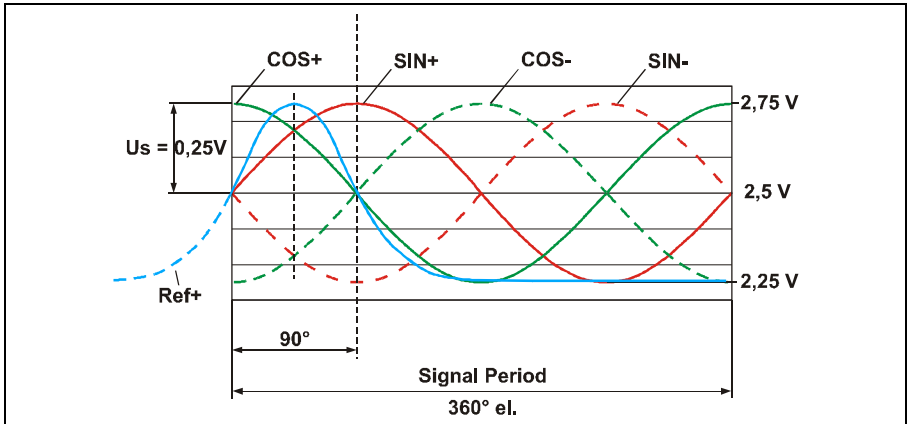

Fig. 4: Signal curve with clockwise direction of rotation looking at the flange connection

Differential measurement of the signals gives the following signal curve:

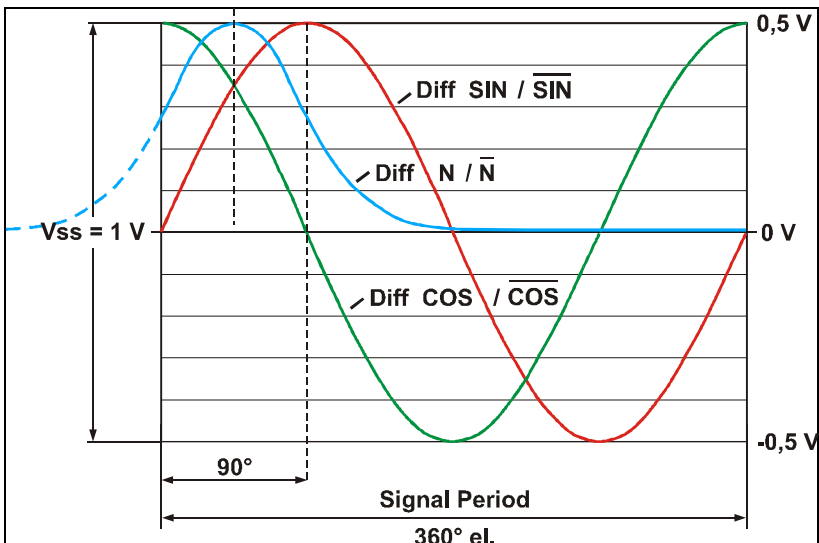

Fig. 5: Signal curve with clockwise direction of rotation looking at the flange connection

7.2 Variant 2, square - wave incremental signals (TTL/HTL)

The number of pulses / revolution is dependent on the device variant. Resolutions of 1024, 2048 and 4096 pulses / revolution are supported.

The output levels are also specified by the factory setting; TTL output stages and HTL output stages are supported.

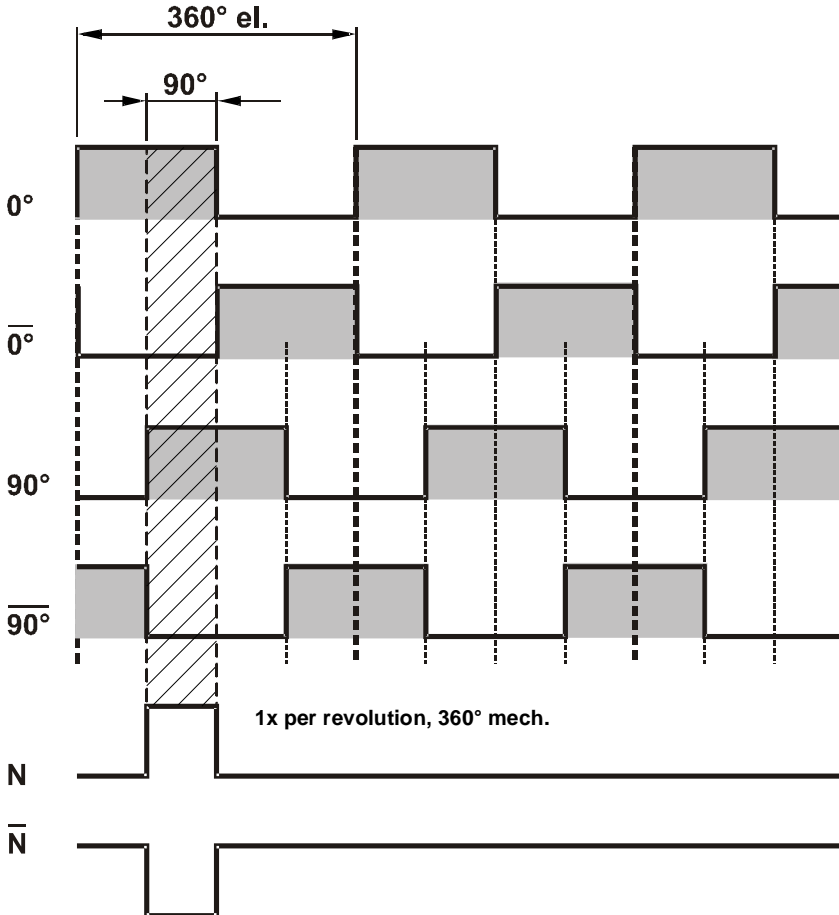
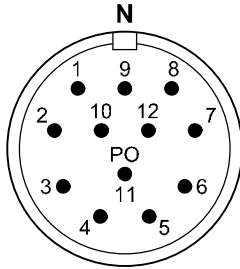

Fig. 6: Signal curve with clockwise direction of rotation looking at the flange connection

8 Connection diagram

Socket insert view



Shield:

The shield of the signal cable is connected at the socket housing.

Pin	Description
1	Output 0°
2	Output 0° Inverse
3	---
4	Output 90°
5	Output 90° Inverse
6	---
7	N *
8	\bar{N} *
9	---
10	---
11	Power Supply
12	GND

* optional

FGH 41T

Connection diagram PN 228-400a

12-pole round plug
M23

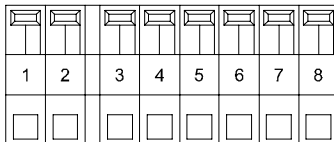

8 pole printed circuit spring terminal block type Phoenix ZFKDS

Connection data:

wire section
0,2-1,5 [mm²]

Shielding:

The shield of the signal cable has to be connected directly to the housing of the encoder by the cable gland.

Pin	Description
1	GND
2	Power Supply
3	Output 0°
4	Output 0° Inverse
5	Output 90°
6	Output 90° Inverse
7	Reference
8	Reference Inverse

FGH 41K

Connection diagram PN 228-410

Terminal box

9 Replacing the Measuring System

The following points must be noted when replacing the measuring system:

- The new measuring system must have the same article number (ID) as the measuring system being replaced; any deviations must be expressly clarified with Johannes Hübner Giessen.
- The new measuring system must be installed in accordance with the specifications and requirements in chapter 5 " Assembly" on page 24 .
- The new measuring system must be connected in accordance with the specifications in chapter 6.7 "Connection instructions for plug connection" on page 36.
- Depending on the application, the output incremental value may need to be adjusted to the machine reference position.
- When recommissioning the replaced measuring system, correct functioning must be ensured first of all by means of a protected test run.

10 Checklist

We recommend that you print out and work through the checklist for commissioning, when replacing the measuring system and when changing the parameterization of a previously accepted system, sign it and store it as part of the overall system documentation.

Documentation reason		Date	Edited	Checked
Sub-item	To note		Can be found under	Yes
Present user manual has been read and understood.			Document no.: FGH41_Manual-en_R0	<input type="checkbox"/>
Check that the measuring system can be used for the preset automation task on the basis of the specified safety requirements	<ul style="list-style-type: none"> • Intended use • Safety functions of the fail-safe processing unit • Compliance with all technical data 	<ul style="list-style-type: none"> • Chapter 2.3 <i>Intended use</i> on page 11 • Chapter 2.5 <i>Safety functions of the fail-safe processing unit</i> on page 12 • Chapter 4 Technical Data on page 18 	<input type="checkbox"/>	
Fulfillment of the installation requirements defined in the user manual	<ul style="list-style-type: none"> • Safe mechanical fixing of the measuring system and safe positive connection of the driving shaft with the measuring system 	<ul style="list-style-type: none"> • Chapter 5 Assembly on page 24 	<input type="checkbox"/>	
Requirement for the power supply	<ul style="list-style-type: none"> • The power supply unit used must meet the requirements of SELV/PELV (IEC 60364-4-41:2005+A1:2017) 	<ul style="list-style-type: none"> • Chapter 4.2 Electrical characteristics on page 19 • Chapter 6.2 EMC requirements on page 30 	<input type="checkbox"/>	
Correct electrical installation (shielding)	<ul style="list-style-type: none"> • Observance of basic rules for installation • Observance of wiring standards 	<ul style="list-style-type: none"> • Chapter 6 Installation / Preparation for Commissioning on page 29 	<input type="checkbox"/>	
System test after commissioning and modifications	<ul style="list-style-type: none"> • During commissioning and after each parameter change all affected safety functions must be checked. 	<ul style="list-style-type: none"> • Chapter 2.5 Safety functions of the fail-safe processing unit on page 12 	<input type="checkbox"/>	
Device replacement	<ul style="list-style-type: none"> • It must be ensured that the new device corresponds to the replaced device. • All affected safety functions must be checked. 	<ul style="list-style-type: none"> • Chapter 9 Replacing the Measuring System on page 40 	<input type="checkbox"/>	

11 Maintenance



WARNING!

At inspection of the measuring system and the mounting, the basic safety instructions contained in chapter 2 must be observed.

The inspection of the measuring system and the mounting must only be carried out by qualified personnel!

The device is maintenance-free. However, to guarantee safe and fault-free operations we recommend that you carry out the following inspections of the measuring system and the mounting on a regular basis. Inspections must be recorded in a log book.

Interval	Inspections
Yearly	Ensure the fastening screws are properly tightened.
	Check the torque bracket (applies to hollow shaft devices only): check link heads can move freely. You must be able to move the link rod manually. If it proves difficult to move, lightly oil the link rod heads or apply lubricant spray.
After approx. 16 000 – 20 000 hours of operation or higher levels of continuous load	Check deep groove ball bearings for noise, running smoothly. Bearings must be replaced by the manufacturer only.

12 Accessories

The accessories/spare parts listed below can be ordered from the service address on page 2 if required

12.1 Draw-off-tool

Draw-off-tool Order-Nr.: ID 23029



for hollow shaft encoder FGH 41 (not included in the scope of delivery)

12.2 Mating connector

Mating connector: BG-109647

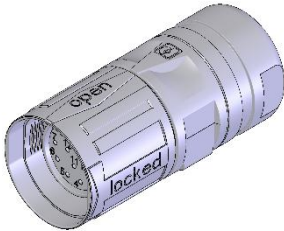

13 Dimension drawings

13.1 FGH 41 T (hollow shaft design)

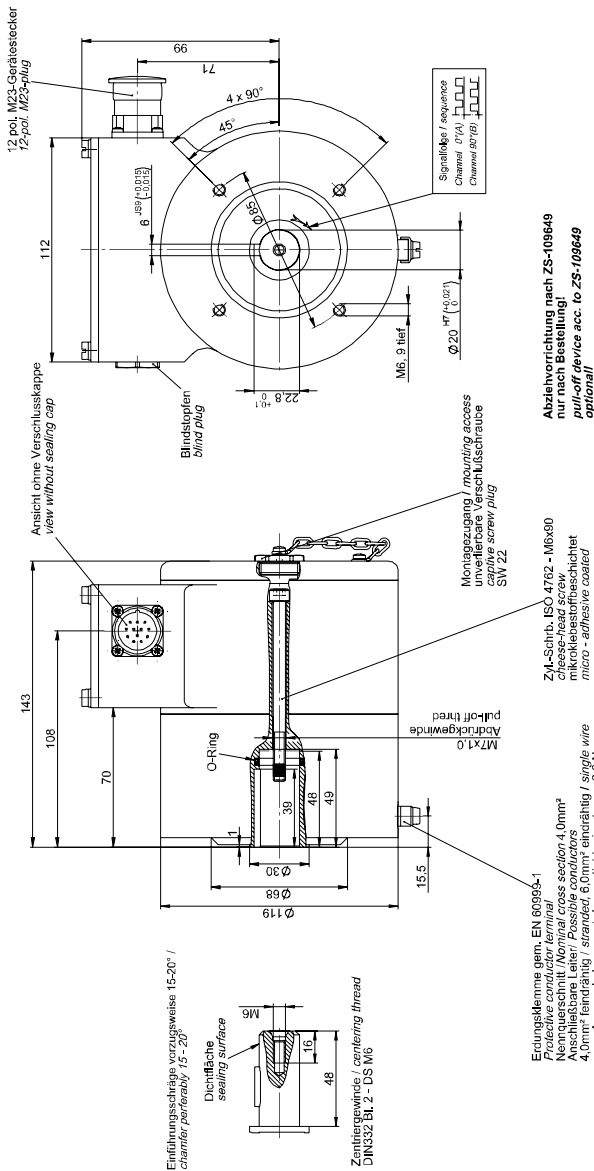

FGH 41 T

12-pole round plug M23

HM 18 M 113294a

13.2 FGH 41 K (hollow shaft design)

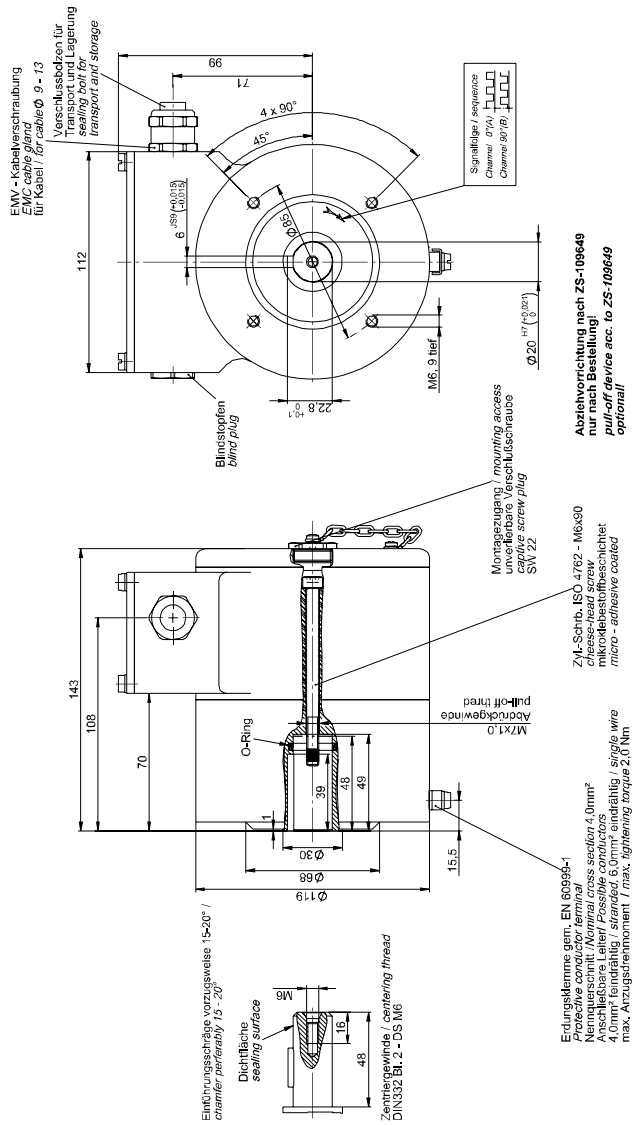

FGH 41 K

Terminal box

HM 19 M 114466

13.3 FGH 41 K (with torque bracket)

