

# Operating and Assembly Instructions

## Electronic overspeed switch EGSHJ 2

Straightforward monitoring of overspeed or zero speed detection

**Read the Operating and Assembly Instructions prior to assembly, starting installation and handling!  
Keep for future reference!**

### Trademark

Protected trademarks bearing a <sup>TM</sup> or ® symbol are not always depicted as such in the manual. However, the statutory rights of the respective owners remain unaffected.

### Manufacturer / publisher

Johannes Hubner  
Fabrik elektrischer Maschinen GmbH  
Siemensstraße 7  
35394 Giessen  
Germany  
Phone: +49 641 7969 0  
Fax: +49 641 73645  
E-Mail: [info@huebner-giessen.com](mailto:info@huebner-giessen.com)  
[www.huebner-giessen.com](http://www.huebner-giessen.com)

The manual has been drawn up with the utmost care and attention. Nevertheless, we cannot exclude the possibility of errors in form and content. It is strictly forbidden to reproduce this publication or parts of this publication in any form or by any means without the prior written permission of Johannes Hubner Fabrik elektrischer Maschinen GmbH.

Subject to errors and changes due to technical improvements.

Copyright © Johannes Hubner  
Fabrik elektrischer Maschinen GmbH  
All rights reserved.

## Directory

<b>1 General</b> .....	<b>5</b>
1.1 Information about the Operating and Assembly Instructions.....	5
1.2 Scope of delivery .....	5
1.3 Explanation of symbols .....	5
1.4 Disclaimer .....	6
1.5 Copyright .....	6
1.6 Guarantee terms .....	6
1.7 Customer service .....	6
<b>2 Safety</b> .....	<b>6</b>
2.1 Responsibility of the owner .....	6
2.2 Personnel.....	6
2.3 Intended use .....	7
2.4 Improper use.....	7
2.5 Personal protective equipment.....	7
2.6 Special dangers .....	8
2.6.1 Electrical current.....	8
2.6.2 Rotating shafts / hot surfaces .....	8
2.6.3 Safeguarding against restart.....	8
<b>3 Technical Data</b> .....	<b>9</b>
3.1 Type plate .....	9
3.2 Type code .....	10
3.3 Electrical and mechanical data.....	10
<b>4 Switching speed range</b> .....	<b>11</b>
4.1 Zero speed monitoring .....	11
<b>5 Transport, packaging and storage</b> .....	<b>12</b>
5.1 Safety instructions for transport.....	12
5.2 Goods inward inspection .....	12
5.3 Packaging / disposal .....	12
5.4 Storage of packages (devices).....	12
<b>6 Installation and commissioning</b> .....	<b>13</b>
6.1 Safety instructions.....	13
6.2 Technical information .....	13
6.3 Required tools.....	13
6.4 Mounting preparations .....	14
6.5 Mounting hollow shaft type.....	14
6.6 Using the adjustable torque bracket .....	15
6.7 Shortenable torque bracket (optional) .....	17
6.8 Electrical connection and start up.....	17
6.8.1 Preparing cables .....	17

6.8.2 Electrical connection.....	17
<b>7 Dismantling .....</b>	<b>18</b>
7.1 Safety instructions.....	18
7.2 Dismantling the encoder .....	18
<b>8 Faults .....</b>	<b>19</b>
8.1 Faults table .....	19
<b>9 Inspections.....</b>	<b>20</b>
9.1 Safety instructions.....	20
9.2 Maintenance information .....	20
9.3 Inspection schedule .....	20
<b>10 Disposal.....</b>	<b>20</b>
10.1 Disposal procedure .....	20
<b>11 Replacement parts.....</b>	<b>20</b>
<b>12 Dimension drawings.....</b>	<b>21</b>
<b>13 Connection diagrams .....</b>	<b>26</b>
13.1 Terminal box .....	26
13.2 Connection cable .....	26

## 1 General

### 1.1 Information about the Operating and Assembly Instructions

These Operating and Assembly Instructions provide important instructions for working with the device. They must be carefully read prior to starting all tasks, and the instructions contained herein must be followed.

In addition, applicable local regulations for the prevention of industrial accidents and general safety regulations must be complied with.

### 1.2 Scope of delivery

Electronic overspeed switch EGSJ 2, Operating and Assembly Instructions. Fixing part according to dimension drawing, if applicable.

### 1.3 Explanation of symbols

Warnings are indicated by symbols in these Operating and Assembly Instructions. The warnings are introduced by signal words that express the scope of the hazard.

The warnings must be strictly heeded; you must act prudently to prevent accidents, personal injury, and property damage.



#### **WARNING!**

Indicates a possibly dangerous situation that can result in death or serious injury if it is not avoided.



#### **CAUTION!**

Indicates a possibly dangerous situation that can result in minor injury if it is not avoided.



#### **CAUTION!**

Indicates a possibly dangerous situation that can result in material damage if it is not avoided.



#### **NOTES!**

Indicates useful tips and recommendations as well as information for efficient and trouble-free operation.



#### **NOTES!**

Do not use a hammer or similar tool when installing the device due to the risk of damage occurring to the bearings or coupling!



#### **DANGER!**

##### **Life-threatening danger due to electric shock!**

Indicates a life-threatening situation due to electric shock. If the safety instructions are not complied with there is danger of serious injury or death. The work that must be executed should only be performed by a qualified electrician.

## 1.4 Disclaimer

All information and instructions in these Operating and Assembly Instructions have been provided under due consideration of applicable guidelines, as well as our many years of experience.

The manufacturer assumes no liability for damages due to:

- Failure to follow the instructions in the Operating and Assembly Instructions
- Non-intended use
- Deployment of untrained personnel
- Opening of the device or conversions of the device

In all other aspects the obligations agreed in the delivery contract as well as the delivery conditions of the manufacturer apply.

## 1.5 Copyright



### NOTES!

Content information, text, drawings, graphics, and other representations are protected by copyright and are subject to commercial property rights.

It is strictly forbidden to make copies of any kind or by any means for any purpose other than in conjunction with using the device without the prior written agreement of the manufacturer. Any copyright infringements will be prosecuted.

## 1.6 Guarantee terms

The guarantee terms are provided in the manufacturer's terms and conditions.

## 1.7 Customer service

For technical information personnel is available that can be contacted by telephone, fax or email. See manufacturer's address on page 2.

# 2 Safety



### DANGER!

This section provides an overview of all the important safety aspects that ensure protection of personnel, as well as safe and trouble-free device operation.

If these safety instructions are not complied with significant hazard can occur.

## 2.1 Responsibility of the owner

The device is used in commercial applications. Consequently the owner of the device is subject to the legal occupational safety obligations and subject to the safety, accident prevention and environmental protection regulations that are applicable for the device's area of implementation.

## 2.2 Personnel

Installation and commissioning as well as disassembly routines must be carried out by skilled technical staff only.

## 2.3 Intended use

The device has been designed and constructed exclusively for the intended use described here.

Series EGSJ 2 electronic overspeed switches are used for speed monitoring, for instance of electrical and mechanical drives, hoisting gear, and conveying machines.

The electronic overspeed switch EGSJ 2 is a overspeed switch, which generates a switching signal for a superior control system. This is realized with opening of a switch contact. As an alternative to this function, the device can also be used for zero speed detection. Not in addition.

Claims of any type due to damage arising from non-intended use are excluded; the owner bears sole responsibility for non-intended use.

## 2.4 Improper use

Do not use the device in potentially explosive areas.

The device must not be subjected to mechanical loads in addition to its own weight and unavoidable vibration and shock loads that arise during normal operations.

Examples for non-permitted mechanical loads (incomplete list):

- Fastening transport or lifting tackle to the device, for example a crane hook to lift a motor.
- Fastening packaging components to the device, for example ratchet straps, tarpaulins etc.
- Using the device as a step, for example by people to climb onto a motor.

## 2.5 Personal protective equipment

For tasks such as assembly, disassembly or commissioning the use of personal protective equipment such as safety footwear and protective work clothing is required.

The regulations specified by the owner and that are locally specified apply.

## 2.6 Special dangers

Residual risks that have been determined based on a risk assessment are cited below.

### 2.6.1 Electrical current



**DANGER!**

**Life-threatening danger due to electrical shock!**

There is an imminent life-threatening hazard if live parts are touched. Damage to insulation or to specific components can pose a life-threatening hazard.

**Therefore:**

Immediately switch off the device and have it repaired if there is damage to the insulation of the power supply.

De-energize the electrical equipment and ensure that all components are connected for all tasks on the electrical equipment.

Keep moisture away from live parts. Moisture can cause short circuits.

### 2.6.2 Rotating shafts / hot surfaces



**WARNING!**

**Danger of injury due to rotating shafts and hot surfaces!**

Touching rotating shafts can cause serious injuries.

**Therefore:**

Do not reach into moving parts/shafts or handle moving parts/shafts during operation. Close to protect from injury all access openings in flanges with the corresponding plug screw, and provided you exposed rotating components with protective covers.

Do not open covers during operation. Prior to opening the covers ensure that all parts have come to a zero speed.

The encoder can become hot during prolonged use.

In case of contact risk of burns is existing.

### 2.6.3 Safeguarding against restart



**DANGER!**

**Life-threatening danger if restarted without authorization!**

When correcting faults there is danger of the power supply being switched on without authorization.

This poses a life-threatening hazard for persons in the danger zone.

**Therefore:**

Prior to starting work, switch off the system and safeguard it from being switched on again.



## 3 Technical Data

### 3.1 Type plate

Type plate example:

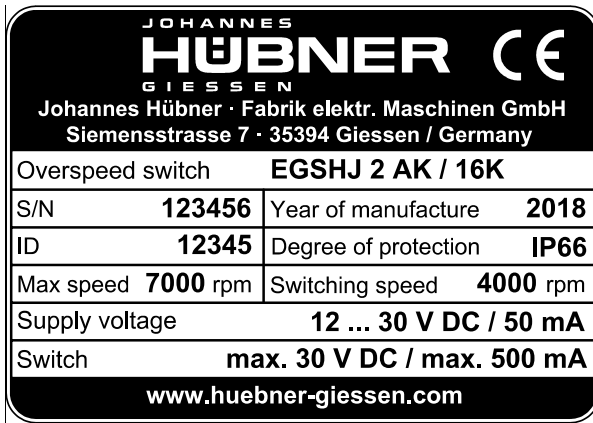

The type plate is located on the outside of the housing and contains the following information:

Englisch	Deutsch
Manufacturer, address	Hersteller, Anschrift
Type: Overspeed switch	Typ: Grenzdrehzahlschalter
Year of manufacture	Baujahr
Item (ID)	Artikel (ID)
CE mark	CE-Kennzeichnung
Serial number (S/N)	Seriennummer (S/N)
Degree of protection	Schutzart
Supply voltage	Versorgungsspannung
Max. speed	Max. Drehzahl
release speed	Schaldrehzahl
Output capacity	Schaltspannung / Schaltstrom

### 3.2 Type code

	EGS(HJ)	2	AK	16K
Electronic overspeed switch				
H: (hollow shaft design)				
HJ: (hollow shaft design with isolated bearings)				
Series				
Connection				
AK = Axial terminal box				
12K: Hollow shaft Ø 12 H7 mm with clamping solution				
16K: Hollow shaft Ø 16 H7 mm with clamping solution				
17C: Hollow shaft Ø 17 mm with conical shaft 1:10				
R75: Hollow shaft Ø 0,75"				

### 3.3 Electrical and mechanical data

Connection data			
Supply voltage	12 ... 30 VDC, max. 50 mA		
Release voltage, current	max. 30 VDC/max. 0,5 A		
Connection	Spring-cage terminal strip type Phoenix ZFKDS 1,5-W-5,08 (0,25 mm <sup>2</sup> - 1,5 mm <sup>2</sup> )		
Device temperature range	-25°C ... + 85°C		
Degree of protection acc.DIN EN 60529	Sealing	Rotor moment of inertia	Breakaway torque Ncm
IP 66	Labyrinth sealing	approx. 315 gcm <sup>2</sup>	approx. 3,5 - 4
Vibration resistance	DIN EN 60068-2-6 / IEC 68-2-6 (10 ... 2000 Hz)		20 g (=200 m/s <sup>2</sup> )
Shock resistance	DIN EN 60068-2-27 / IEC 68-2-27 (6 ms)		200 g (=2000 m/s <sup>2</sup> )
Max. permissible. speed:	6000 rpm		
Weight	approx. 2 kg		

## 4 Switching speed range

The electronic overspeed switch EGSJ 2 has a galvanically insulated switching output. The switching function is realized with a semiconductor, the switching speed is set in our factory (switching hysteresis 10%). Possible value for switching speed is any whole number between 1 and 5400 rpm. If the set switching speed is exceeded, the switch opens.

It is recommended to save the switch circuit against an overcurrent with a fuse (0,5A).

Specification	Value
Switching speed range, factory-set	AK with hollow shaft max. 5400 rpm
Deviation from switch:	Accuracy of measurement: 2% Switching time $T_{sw} < 3ms$
Switch data	0...30 VDC/max 500mA Max. voltage drop at closed switch: 0,7V

### 4.1 Zero speed monitoring

The zero speed monitoring is a function for the control of rotary movements. This function is available as an alternative to overspeed monitoring, not in addition. The galvanically isolated switching contact changes the state as soon as the shaft leaves the zero speed.

Functionality:

At a speed of less than 0.25 rpm the zero speed monitoring is activated and the switching contacting contact is closed. When the zero speed monitoring is activated, the current position value is stored and monitored for possible changes in the angle of rotation. As a result, very slow or creeping wave movements can also be detected. In the speed range from 0 to 0.25 rpm, the switching contact opens for approx. 200 - 400 milliseconds after a change in the angular position of  $\pm 5^\circ$ . The possible switching contact states are shown in the following table.

The switching contact is closed at zero speed ( $n = 0$  rpm).

For rotary movement ( $n \geq 0.25$  rpm), the switching contact is open.

At a creep motion ( $0 < n < 0.25$  rpm), the switching contact opens as soon as a change in the angle of rotation of more than  $\pm 5^\circ$ . After 200 to 400 ms, the switching contact is closed again as long as the speed is less than 0.25 rpm.

Rotation speed n [rpm]	State	Switching contact
n = 0 (zero speed)		
n ≥ 0,25 (rotary motion)		
0 < n < 0,25 (creep motion)		switching contact opens for approx. 200 - 400 milliseconds after a change in the angular position of $\pm 5^\circ$

## 5 Transport, packaging and storage

### 5.1 Safety instructions for transport



**CAUTION!**

**Material damage caused by improper transport!**

Observe the symbols and information on the packaging:

- Do not throw - risk of breakage
- Keep dry
- Do not expose to heat above 40 °C or direct sunlight.

### 5.2 Goods inward inspection

Check the delivery immediately upon receipt for transit damage or short delivery.

Inform the carrier immediately on receipt if you determine that damage has occurred during transit (take photos as proof).

### 5.3 Packaging / disposal

The packaging is not taken back and must be disposed of in accordance with the respective statutory regulations and local guidelines.

### 5.4 Storage of packages (devices)



**Keep dry**

Keep packages dry and free from dust; protect from moisture.

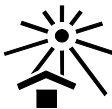

**Protect against heat**

Protect packages from heat above 40 °C and direct sunlight.

If you intend to store the device for a longer period of time (> 6 months) we recommend you use protective packaging (with desiccant).



**NOTES!**

Turn the shaft of the device every 6 month to prevent the bearing grease solidifying!

## 6 Installation and commissioning

### 6.1 Safety instructions

#### Personnel

Installation and commissioning must be carried out by skilled technical staff only.



#### WARNING!

Observe the safety instructions contained in **Chapter 2** when dismantling the device!

### 6.2 Technical information



#### NOTES!

Do not use a hammer or similar tool when installing the device due to the risk of damage occurring to the bearings or coupling!

#### Ambient temperature

The max. permissible ambient temperature depends on the speed and degree of protection of the device, the signal frequency, the length of the signal cable and the place of installation (please refer to Chapter 3.3).

#### Degree of protection

To fulfil degree of protection requirements the diameter of the connection cable must correspond to that of the cable gland (please refer to Chapter 12 Dimension drawings)!

#### Deep groove ball bearings

EGS 2 overspeed switches are fitted with maintenance-free, greased "for-life" deep groove bearings. Bearings must be changed by the manufacturer only. Opening the encoder renders the guarantee null and void.

#### Screw retention

We recommend using Loctite® 243 threadlocker (medium strength) on all fastening screws to prevent loosening.

### 6.3 Required tools

- Spanners: 10 mm, 12 mm, 22 mm (e.g. DIN 894)
- Allen keys: 2 mm, 3 mm, 5 mm, 6 mm
- Flat-blade screwdrivers:
- Assembly grease
- Loctite® 243 (medium strength threadlocker)

## 6.4 Mounting preparations

1. Ensure all accessories are available (please refer to Chapter 12 Dimension drawings).



**NOTES!**

Fastening screws and earth cable are not included in the range of supply.

2. Preparing the place of attachment: Clean the (motor) shaft, centering, bolting surfaces and fastening threads; check for damage. Repair any damage!

## 6.5 Mounting hollow shaft type

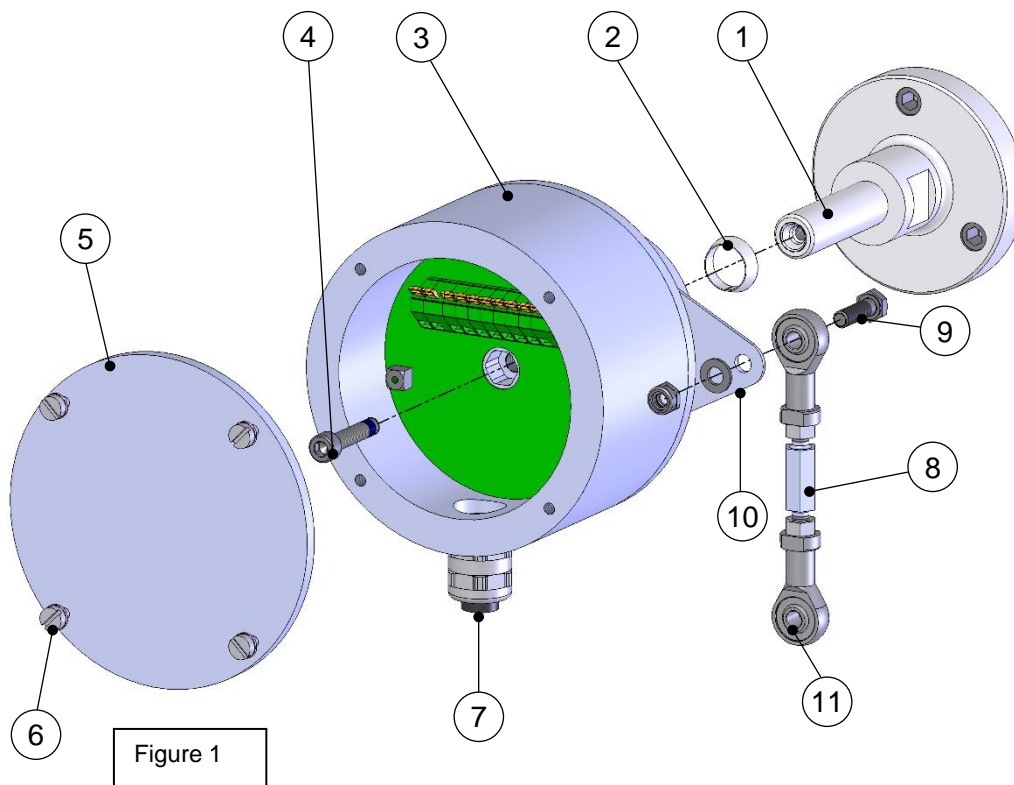

1. Mount adapter shaft (1) and align using dial gauge.



**NOTES!**

The maximum radial run-out of the adapter shaft/motor shaft should not exceed 0,2 mm. We recommend a radial deviation of 0,03 mm.

If necessary, use the ball thrust adjustment screw to align the adapter shaft. Secure ball thrust screws with Loctite® 243. Remove unused ball thrust screws or secure with Loctite® 243. Max. tightening torque for M12 approx. 25 Nm, for M16 approx. 35 Nm.

Use parallel keys to DIN 6885.

Please also observe the supplement data sheet *Mounting accuracy for hollow shaft encoders*.

You should also observe the Installation instructions supplied with the adapter shaft when installing!

2. Lightly grease the adapter shaft, open the device.
3. Slide the circular spring device (2) onto the adapter shaft until it stops.
4. Mount the hollow shaft device (3) to the adapter shaft.

The hollow shaft encoder must slide smoothly on to the adapter shaft. In no delay with increased force, otherwise the bearing may be damaged. Where appropriate adapter shaft with emery cloth rework. The hollow shaft encoder does not strike hard against the shaft shoulder.

5. Secure the hollow shaft device with the aid of the hexagon socket head cap screw (4). (Fig.1) maximum tightening 6 Nm.



**NOTES!**

The cap screws have a coating with micro-encapsulated adhesive for securing screws. If screws are used without micro-adhesive coating the screws are with Loctite® 243 to be secured.

6. Close the hollow shaft device with cover (5) and 4 screws (6).
7. Fastening the torque bracket:

Bolt the link rod (8) with screw (9), washer and nut with torque bracket (10).

The ideal angle of torque bracket (10) to the link rod (8) is 90°.

Secure the link heads (11) of the link rod to a fixed point (for example on the motor housing).



**NOTES!**

Once fitted the link rod must rotate easily around the link rod heads! Failure to observe this point may result in damage to the bearings!



**NOTES!**

The link heads are maintenance free. However, ensure they remain free from soiling and paint!

## 6.6 Using the adjustable torque bracket

The torque bracket is supplied completely screwed together. To adjust the length of the torque bracket, release the interlocked nuts. Turn the rigging screw to the left or to the right to adjust the torque bracket to the required length. Then tighten the hex nuts to lock the adjusted length.

Number	ID Number	Minimum length (mm)	Maximum length (mm)
1	21402	141	180
2	21403	180	250
3	21404	250	350

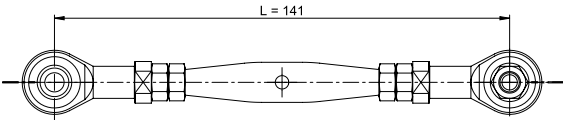
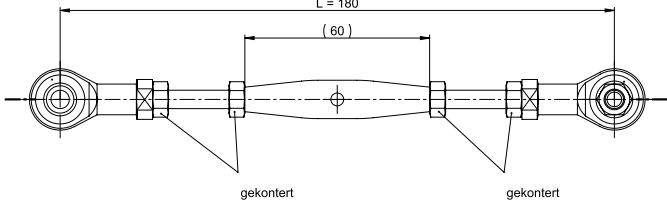
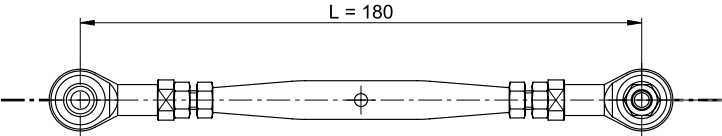
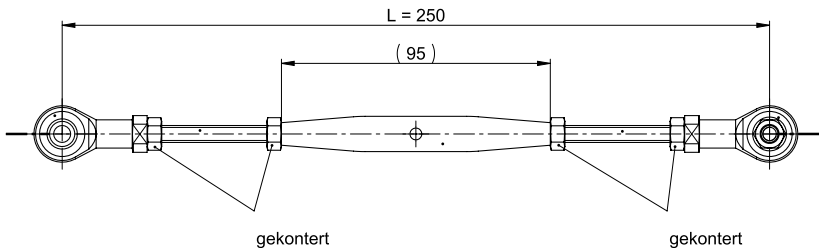
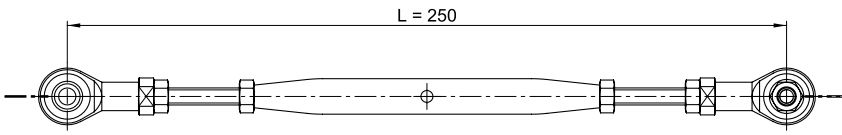
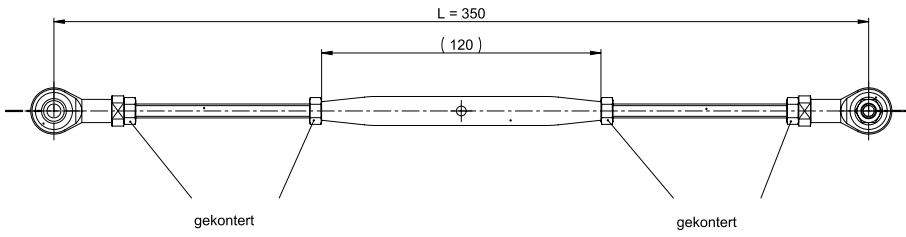
	<p>Number 1 <b>min.</b> length in mm</p>
	<p>Number 1 <b>max.</b> length in mm</p>
	<p>Number 2 <b>min.</b> length in mm</p>
	<p>Number 2 <b>max.</b> length in mm</p>
	<p>Number 3 <b>min.</b> length in mm</p>
	<p>Number 3 <b>max.</b> length in mm</p>



## 6.7 Shortenable torque bracket (optional)

The torque arms in the table below can be shortened by the customer.  
See dimension drawing HM 13 M 106952a Chapter 12.

Type	ID Number	Min. length (mm)	Max. length (mm)
D	21975	71	390
E	22057	71	430

## 6.8 Electrical connection and start up



### NOTES!

You must observe applicable EMC guidelines when routing cables!

### 6.8.1 Preparing cables

1. Strip cable insulation.
2. Crimp wire-end ferrules.

### 6.8.2 Electrical connection

1. Open the terminal box cover (15, Fig.1).



### CAUTION!

Do not allow moisture to enter the terminal box when the cover is open!

2. Remove the cap of the cable gland (7, Fig.1).
3. Feed the cable into the terminal box trough the cable gland.
4. Tighten the cable gland using a spanner.



### NOTES!

Prior to delivery cable glands and blanking plugs are tightened finger tight only. To ensure that the terminal box is reliably sealed tighten all cable glands and blanking plugs before starting up for the first time.

5. Use a spanner to tighten the cable gland until the cables are securely clamped and properly sealed.



### NOTES!

Prevent lateral pulling forces acting on the cable so as not to impair the degree of protection of the cable gland.

6. Connect the supply voltage, and the signal cable (please refer to the connection diagrams, Chapter 13).
7. Close the terminal box cover.



**NOTES!**

Before closing the terminal box cover check and if necessary clean both seal surfaces and the gasket.



**CAUTION!**

Ensure when closing the terminal box cover that no cable becomes jammed.

## 7 Dismantling

### 7.1 Safety instructions

**Personnel**

Dismantling must be carried out by skilled technical staff only.



**WARNING!**

Observe the safety instructions contained in **Chapter 2** when dismantling the device!



**NOTES!**

Do not use a hammer or similar tool when dismantling the device due to the risk of damage occurring to the bearings or coupling!

### 7.2 Dismantling the encoder

Disconnect all electrical cable prior to beginning any work.

To dismantling the device follow the instructions given in Chapter 6.5 in the reverse order. For dismounting first a threaded pin M6x10 ISO 7436 has to be screwed into the adapter shaft. With a screw M8, the device must be pressed. Optionally, the adapter shaft must be secured against turning

## 8 Faults

### 8.1 Faults table

Faults	Possible cause	Remedy
Switch does not close	No supply voltage <u>Control</u> : LED in the terminal box does not shine	Check connection cable and supply voltage
	<u>Error LED does not shine</u> : Rotation speed above the switching speed	Adjust the suitable rotation speed
	<u>Error LED is shining</u> : Evaluation of rotation speed is faulty.	Disconnect power supply and switch on again
Moisture in the terminal box	Soiled terminal box gasket or seal surfaces	Clean terminal box gasket and seal surfaces
	Damaged terminal box gasket	Replace terminal box gasket
	Cable gland/blanking plug not tightened	Tighten cable gland/blanking plug
	Unsuitable cable for cable gland	Use suitable cable and cable glands
Contact Hubner-Service (page 2) if none of the remedies listed above provides a solution!		

## 9 Inspections

### 9.1 Safety instructions



**WARNING!**

Skilled technical staff only are permitted to inspect the device and its installation. Observe the safety instructions contained in **Chapter 2** when inspecting or working on the device!

### 9.2 Maintenance information

The device is maintenance-free. However, to guarantee optimum fault-free operations we recommend that you carry out the following inspections.

### 9.3 Inspection schedule

Interval	Inspections
Yearly	Ensure the fastening screws are properly tightened
	Ensure cable connections and connection terminals are securely seated
	Check the torque bracket
Following approx 16 000 – 20 000 hours of operation / higher levels of continuous load	Check deep groove ball bearings are running smoothly and listen for running noises. Bearings must be replaced by the manufacturer only.

## 10 Disposal

### 10.1 Disposal procedure

The manufacturer is not obliged to take back the device.

The device is classed as electronic equipment; observe local country-specific laws when disposing of the device.

For information on environmentally sound disposal please contact your local authority or a specialist disposal company.

## 11 Replacement parts

The replacement parts listed below can be obtained via the service address on page 2.

Replacement parts	Comment
Cable gland	M 20 x 1.5, cable Ø 5...14 mm
Terminal box cover	Including O-Ring and screws

## 12 Dimension drawings

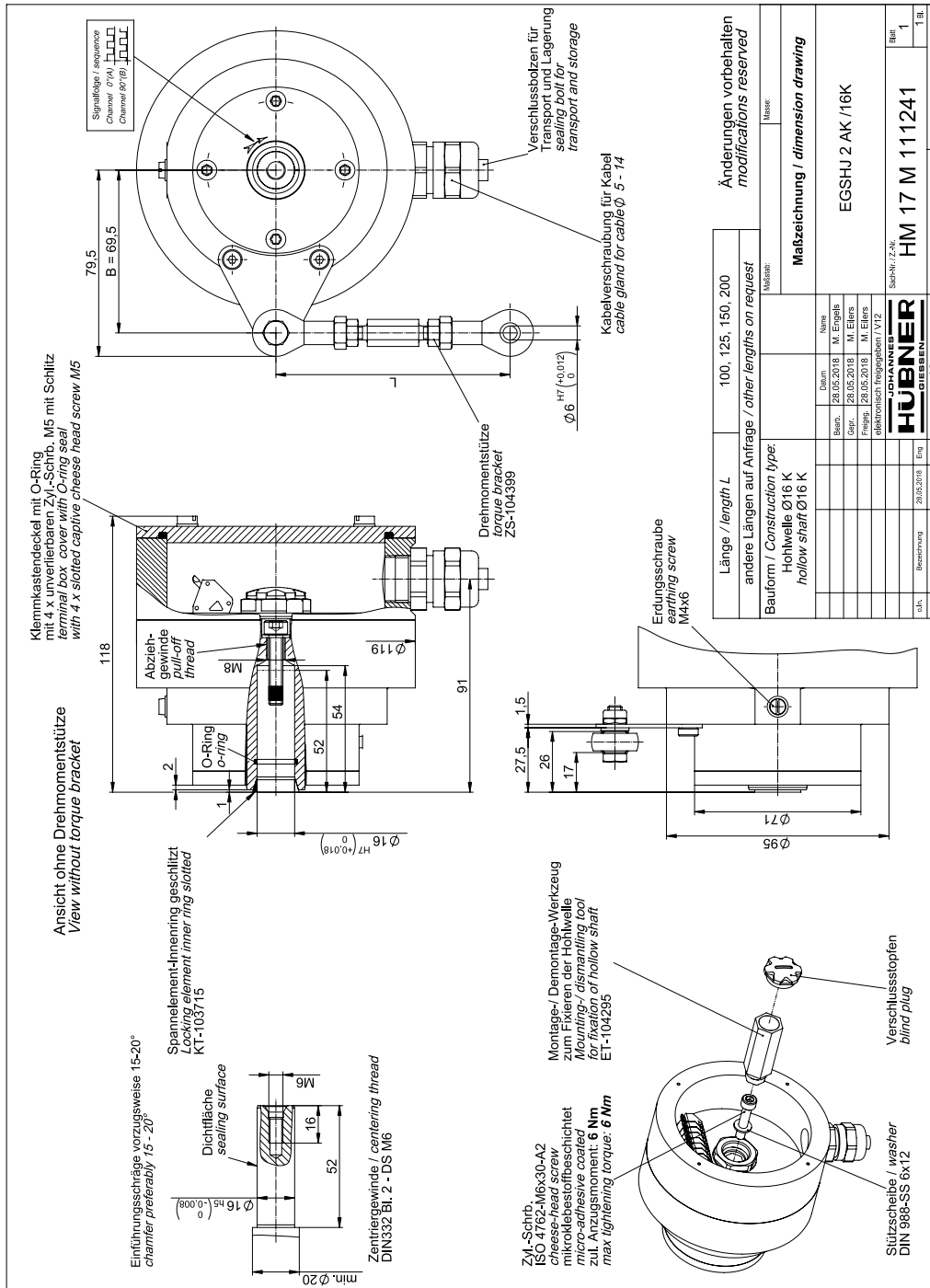

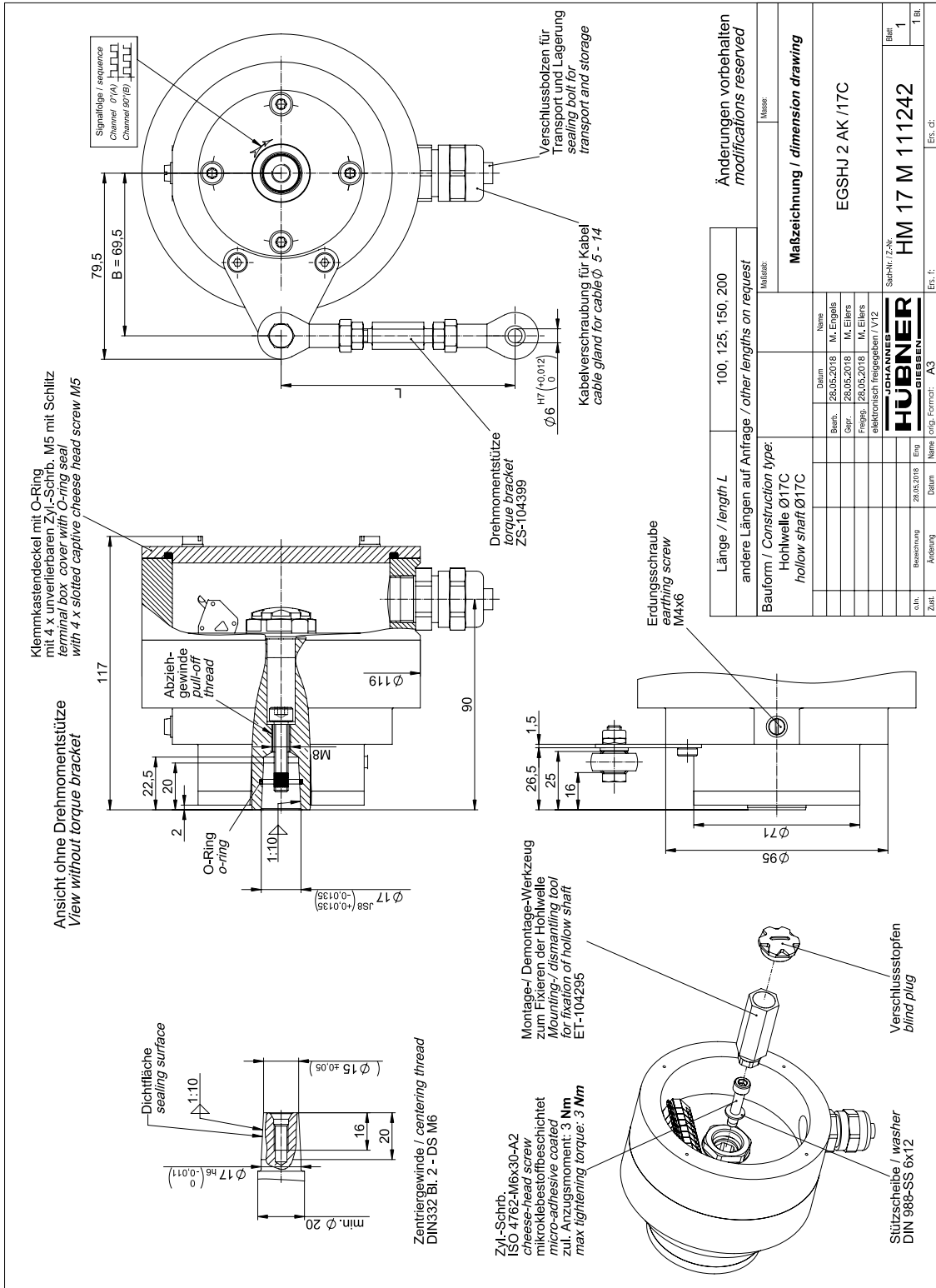

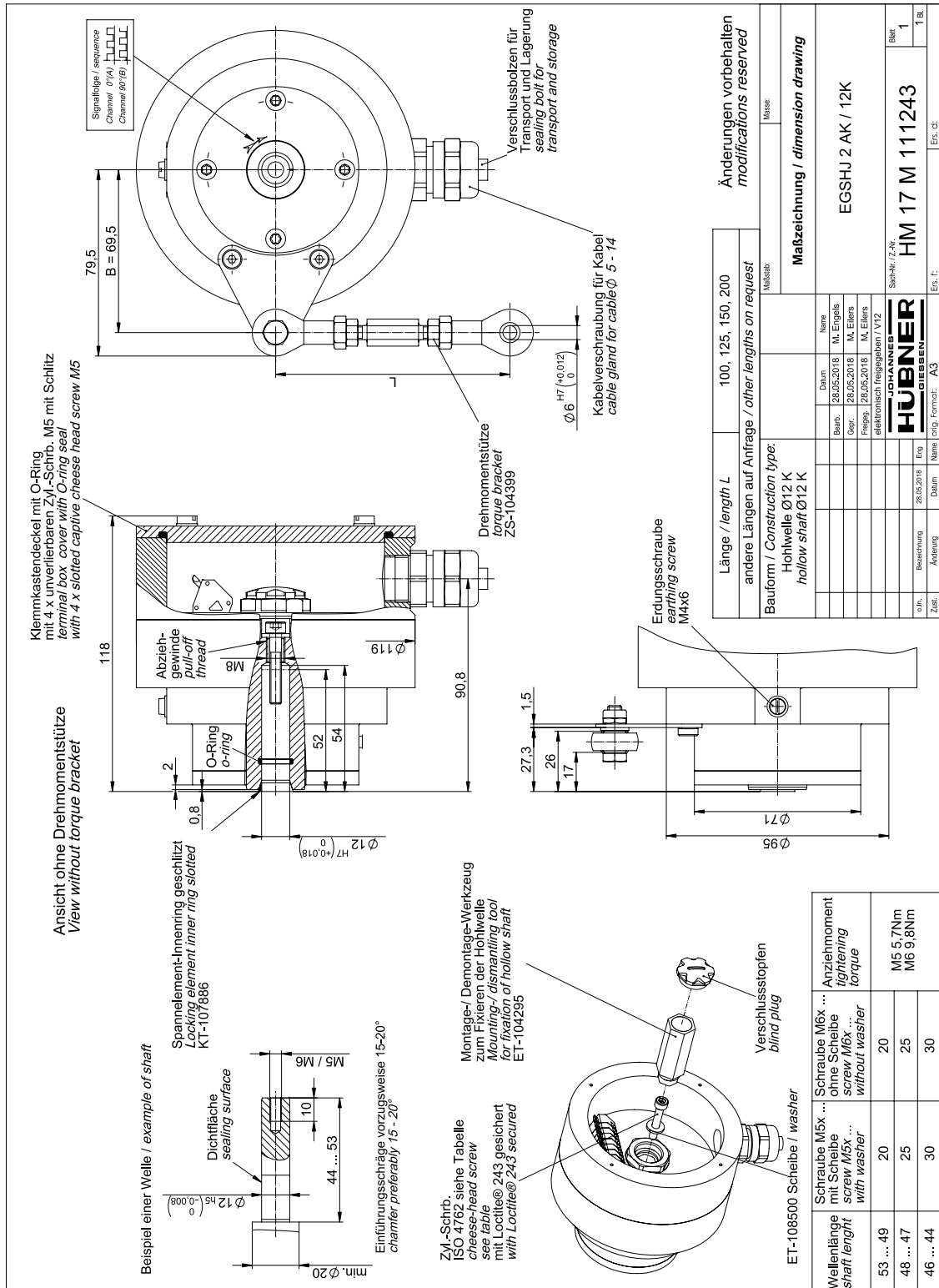

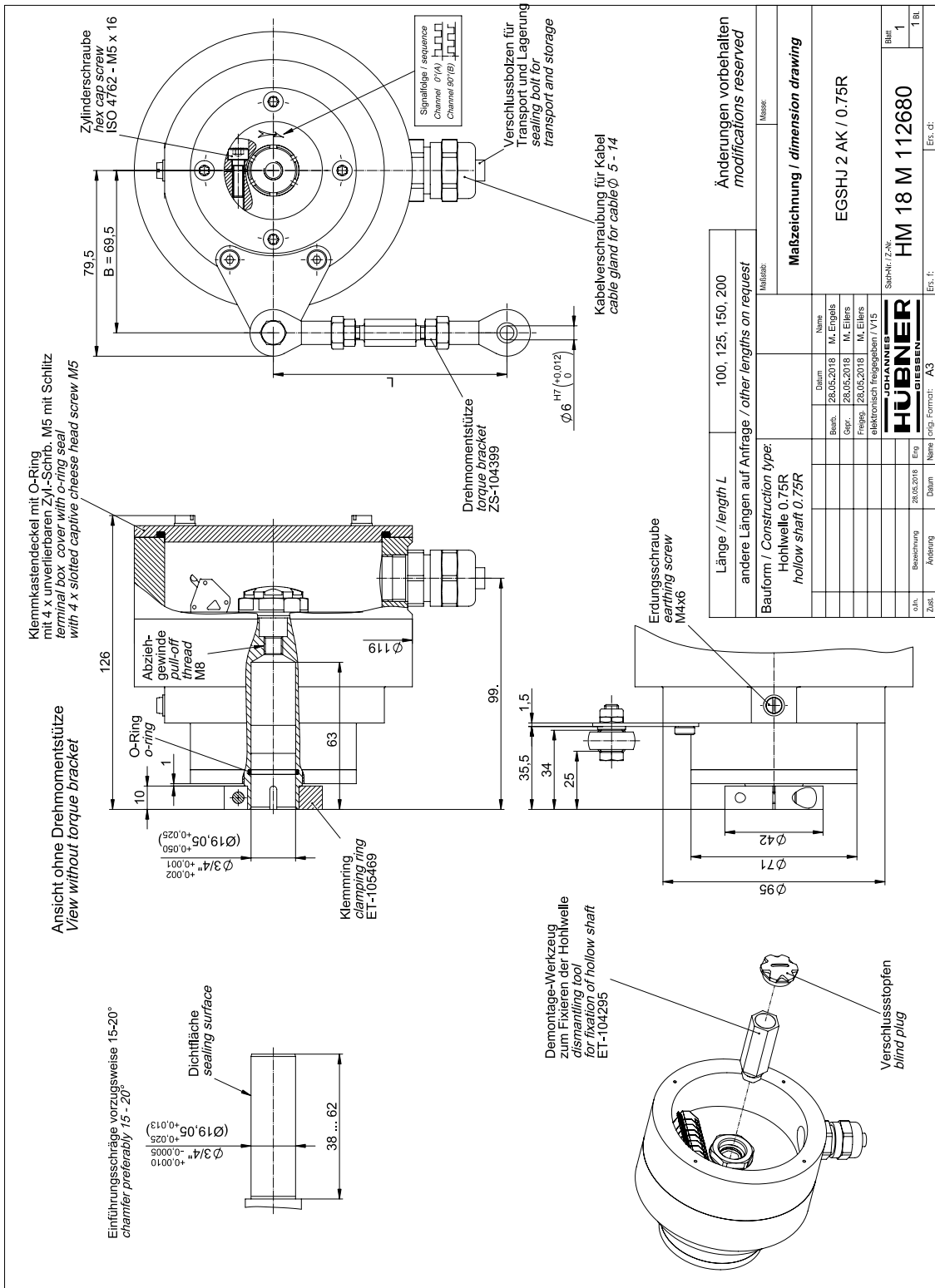



# Electronic overspeed switch EGSJ 2

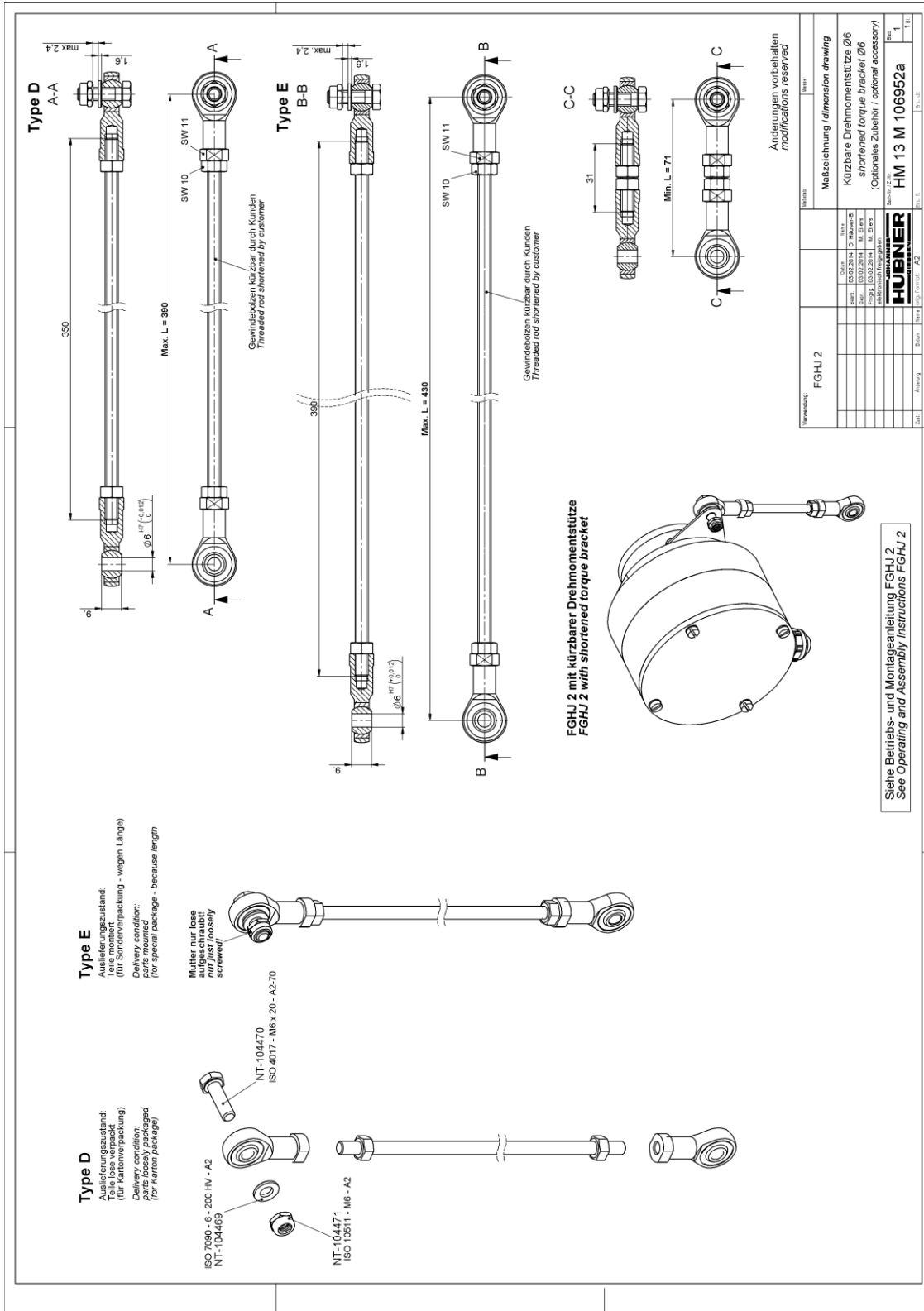

## 13 Connection diagrams

### 13.1 Terminal box



**NOTES!**

The connection diagrams are displayed in each terminal box cover!

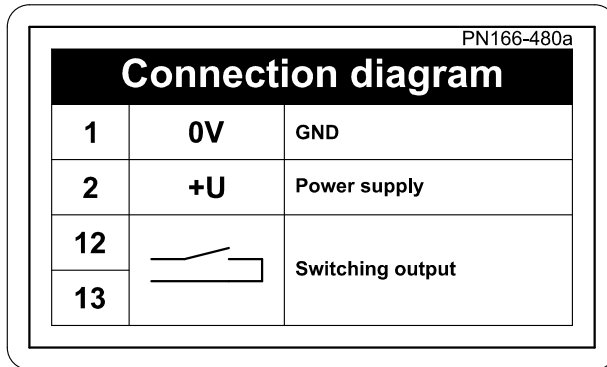

Connection diagram PN166-480a

### 13.2 Connection cable



**NOTES!**

The connection diagrams are attached to each cable!

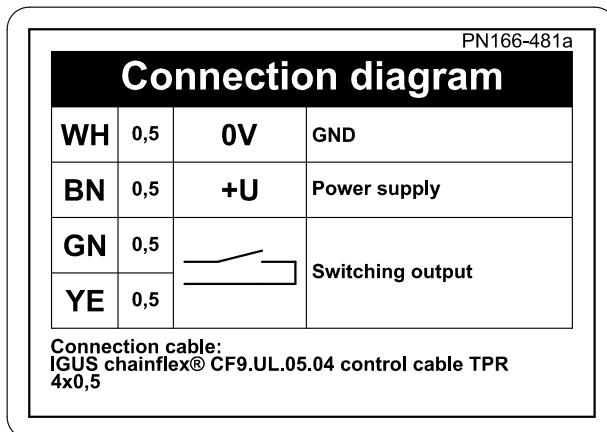

Connection diagram PN166-481a