



Construction type B35



Hollow shaft design

Operating and Assembly Instructions

ELECTRONIC OVERSPEED SWITCH

EGS[®] 41 in construction type B5 (flange), B35 (flange and foot)

EGS[®] H 41 (hollow shaft design)

certificated according EN 61508 SIL2 and DIN EN ISO 13849-1 PL d

Read the Operating and Assembly Instructions prior to assembly, starting installation and handling!
Keep for future reference!



Trademark

EGS® is a registered trademark of Johannes Hubner Fabrik elektrischer Maschinen GmbH.

Windows® is a registered trademark of Microsoft Corporation in the Unites States and other countries.

Viton® is a registered trademark by Du Pont.

Loctite® is a registered trademark.

All other brand names and product names are trademarks or registered trademarks of their respective owner.

Protected trademarks bearing a ™ or ® symbol are not always depicted as such in the manual.

However, the statutory rights of the respective owners remain unaffected.

Manufacturer / publisher

Johannes Hubner

Fabrik elektrischer Maschinen GmbH

Siemensstraße 7

35394 Giessen

Germany

Phone: +49 641 7969 0

Fax: +49 641 73645

E-Mail: info@huebner-giessen.com

www.huebner-giessen.com

Headquarters: Giessen

Court of registration: Giessen

Commercial register number: HRB 126

The manual has been drawn up with the utmost care and attention. Nevertheless, we cannot exclude the possibility of errors in form and content. It is strictly forbidden to reproduce this publication or parts of this publication in any form or by any means without the prior written permission of Johannes Hubner Fabrik elektrischer Maschinen GmbH.

Subject to errors and changes due to technical improvements.

Copyright © Johannes Hubner Fabrik elektrischer Maschinen GmbH

All rights reserved.

Directory

1	General.....	5
1.1	Information about the Operating and Assembly Instructions	5
1.2	Scope of delivery.....	5
1.3	Explanation of symbols	5
1.4	Disclaimer.....	6
1.5	Copyright.....	6
1.6	Guarantee terms	6
1.7	Customer service	6
2	Safety	6
2.1	Responsibility of the owner	6
2.2	Personnel	6
2.3	Personal protective equipment	7
2.4	Special dangers	7
2.4.1	Electrical current	7
2.4.2	Rotating shafts / Hot surfaces	7
2.4.3	Safeguarding against restart	7
3	Technical Data.....	8
3.1	Type plates.....	8
3.2	Type key.....	9
3.3	Electrical and mechanical data	10
3.3.1	Connected loads, environment	10
3.3.2	Electrical Outputs	10
3.3.3	Mechanical Data.....	11
3.3.4	Degree of protection	11
4	Installation and commissioning	12
4.1	Safety instructions	12
4.2	Technical information	13
4.3	Required tools	14
4.4	Mounting preparations	14
4.5	Mounting B5 type (flange).....	15
4.6	Mounting B35 type (flange and foot).....	16
4.7	Mounting tolerances for Construction Type B5 and B35	18
4.8	Coupling	18
4.9	Attaching additional devices.....	19
4.10	Mounting hollow-shaft type overspeed switches	21
4.11	Dismantling.....	23
4.11.1	Safety instruction	23
4.11.2	Dismantling the encoder type B5 and B35.....	23
4.11.3	Dismantling hollow shaft type overspeed switches.....	23
4.12	Electrical connection and start up	24
4.12.1	Preparing cables	24
4.12.2	Electrical connection	24

5	Structure and function	25
5.1	Brief description	25
6	Functional safety	26
6.1	Device data	26
6.1.1	Characteristic safety values	26
6.1.2	Timing	27
6.1.3	Switching accuracy	27
6.1.4	Safe state	27
6.1.5	Service life of the bearings	28
6.2	Intended use	29
6.3	Improper use	29
6.4	Inspections	29
6.4.1	Safety instructions personnel	29
6.4.2	Maintenance information	29
6.4.3	Inspection schedule	30
6.5	Fault table	30
6.6	Error table	31
7	Replacement parts	32
8	Transport, packaging and storage	33
8.1	Safety information concerning transport	33
8.2	Goods inward inspection	33
8.3	Packaging (disposal)	33
8.4	Storing packages (devices)	33
8.5	Returning devices (repairs/goodwill/warranty)	34
8.6	Disposal	34
9	Dimension drawings	35
9.1	EGS 41 dimension drawings	35
9.1.1	Construction type B5 (flange)	35
9.1.2	Construction type B35 (flange and foot)	36
9.1.3	Construction Type B5/B14 (flange, with 2. shaft end)	38
9.1.4	Construction type B35/B14 (flange and foot, with 2. shaft end)	40
9.2	Assembly devices	42
9.3	EGSH 41 – dimension drawings	44
10	Connection Diagram	48
10.1	Connections	48
11	Certificate	50

1 General

1.1 Information about the Operating and Assembly Instructions

These Operating and Assembly Instructions provide important instructions for working with the device. They must be carefully read prior to starting all tasks, and the instructions contained herein must be followed.

In addition, applicable local regulations for the prevention of industrial accidents and general safety regulations must be complied with.

1.2 Scope of delivery

Scope of delivery includes the overspeed switch, the Operating and Assembly Instructions (with SIL-safety instructions) the programming software EGS41Pro (CD-ROM), and the programming cable.

1.3 Explanation of symbols

Warnings are indicated by symbols in these Operating and Assembly Instructions. The warnings are introduced by signal words that express the scope of the hazard.

The warnings must be strictly heeded; you must act prudently to prevent accidents, personal injury, and property damage.



WARNING!

Indicates a possibly dangerous situation that can result in death or serious injury if it is not avoided.



CAUTION!

Indicates a possibly dangerous situation that can result in minor injury if it is not avoided.



CAUTION!

Indicates a possibly dangerous situation that can result in material damage if it is not avoided.



NOTES!

Indicates useful tips and recommendations as well as information for efficient and trouble-free operation.



NOTES!

Do not use a hammer or similar tool when installing the device due to the risk of damage occurring to the bearings or coupling!



DANGER!

Life-threatening danger due to electric shock!

Indicates a life-threatening situation due to electric shock. If the safety instructions are not complied with there is danger of serious injury or death. The work that must be executed should only be performed by a qualified electrician.

1.4 Disclaimer

All information and instructions in these Operating and Assembly Instructions have been provided under due consideration of applicable guidelines, as well as our many years of experience.

The manufacturer assumes no liability for damages due to:

- Failure to follow the instructions in the Operating and Assembly Instructions
- Non-intended use
- Deployment of untrained personnel
- Opening of the device or conversions of the device

In all other aspects the obligations agreed in the delivery contract as well as the delivery conditions of the manufacturer apply.

1.5 Copyright



NOTES!

Content information, text, drawings, graphics, and other representations are protected by copyright and are subject to commercial property rights.

It is strictly forbidden to make copies of any kind or by any means for any purpose other than in conjunction with using the device without the prior written agreement of the manufacturer. Any copyright infringements will be prosecuted.

1.6 Guarantee terms

The guarantee terms are provided in the manufacturer's terms and conditions.

1.7 Customer service

For technical information personnel is available that can be reached per telephone, fax or email. See manufacturer's address on page 2.

2 Safety



DANGER!

This section provides an overview of all the important safety aspects that ensure protection of personnel, as well as safe and trouble-free device operation.

If these safety instructions are not complied with significant hazard can occur.

2.1 Responsibility of the owner

The device is used in commercial applications. Consequently the owner of the device is subject to the legal occupational safety obligations, and subject to the safety, accident prevention, and environmental protection regulations that are applicable for the devices area of implementation.

2.2 Personnel

Installation and commissioning as well as disassembly routines must be carried out by skilled technical staff only.

2.3 Personal protective equipment

Wear personal protective equipment such as safety shoes and safety clothing to minimise risks to health and safety when carrying out work such as installation, disassembly or commissioning. Adhere to all applicable statutory regulations as well as the rules and standards determined by the owner.

2.4 Special dangers

Residual risks that have been determined based on a risk analysis are cited below.

2.4.1 Electrical current



DANGER!

Life-threatening danger due to electrical shock!

There is an imminent life-threatening hazard if live parts are touched. Damage to insulation or to specific components can pose a life-threatening hazard.

Therefore:

Immediately switch off the device and have it repaired if there is damage to the insulation of the power supply.

De-energize the electrical equipment and ensure that all components are connected for all tasks on the electrical equipment.

Keep moisture away from live parts. Moisture can cause short circuits.

2.4.2 Rotating shafts / Hot surfaces



WARNING!

Danger of injury due to rotating shafts and hot surfaces!

Touching rotating shafts can cause serious injuries.

Therefore:

Do not reach into moving parts/shafts or handle moving parts/shafts during operation.

Close to protect from injury all access openings in flanges with the corresponding plug screw, and provided you exposed rotating components with protective covers.

Do not open covers during operation. Prior to opening the covers ensure that all parts have come to a standstill.

The encoder can become hot during prolonged use.

In case of contact risk of burns is existing.

2.4.3 Safeguarding against restart



DANGER!

Life-threatening danger if restarted without authorization!

When correcting faults there is danger of the power supply being switched on without authorization.

This poses a life-threatening hazard for persons in the danger zone.

Therefore:

Prior to starting work, switch off the system and safeguard it from being switched on again.

3 Technical Data

3.1 Type plates

Below are some nameplates for different device models shown.

JOHANNES HÜBNER CE GIESSEN Siemensstrasse 7 · 35394 Giessen / Germany www.huebner-giessen.com	
Drehzahlschalter / Overspeed switch	
EGS 41 K	
S/N 123456	C/N 12345678
Bj./Y 2018	IP66/67
max. Drehzahl max. speed 1800 rpm	Versorgungsspg. / Power supply 12-30 V DC, max. 3 W
Schalter / Switches S1/S2: max. 230 V / 250 mA AC/DC Diag: max. 30 V / 50 mA DC	
Zertifiziert nach / Certified through IEC 61508 - SIL2 + DIN EN ISO 13849 PLd	

Example EGS 41 K

Siemensstrasse 7 JOHANNES 35394 Giessen / Germany HÜBNER CE www.huebner-giessen.com GIESSEN			
Drehzahlschalter / Overspeed switch			
EGS 41 KK			
S/N 123456	C/N 12345678	Bj./Y 2018	IP65
← EGS →		← EGS →	
max. Drehzahl / max. speed 1800 rpm		max. Drehzahl / max. speed 1800 rpm	
Versorgungsspg. / Power supply 12-30 V DC, max. 3 W		Versorgungsspg. / Power supply 12-30 V DC, max. 3 W	
Schalter / Switches S1/S2: max. 230 V / 250 mA AC/DC Diag: max. 30 V / 50 mA DC		Schalter / Switches S1/S2: max. 230 V / 250 mA AC/DC Diag: max. 30 V / 50 mA DC	
Zertifiziert nach / Certified through IEC 61508 - SIL2 DIN EN ISO 13849 PLd		Zertifiziert nach / Certified through IEC 61508 - SIL2 DIN EN ISO 13849 PLd	

Example EGS 41 KK

Siemensstrasse 7 JOHANNES 35394 Giessen / Germany HÜBNER CE www.huebner-giessen.com GIESSEN			
Drehzahlschalter / Overspeed switch			
EGS 41 KK-HV			
S/N 123456	C/N 12345678	Bj./Y 2018	IP65
← EGS →		← Power →	
max. Drehzahl / max. speed 1800 rpm			
		Versorgungsspg. / Supply voltage 100-240 V AC/DC, max. 3 W	
Schalter / Switches S1/S2: max. 230 V / 250 mA AC/DC Diag: max. 30 V / 50 mA DC			
Zertifiziert nach / Certified through IEC 61508 - SIL2 DIN EN ISO 13849 PLd		Zertifiziert nach / Certified through IEC 61508 - SIL2 DIN EN ISO 13849 PLd	

Example EGS 41 KK - HV

Siemensstrasse 7 JOHANNES 35394 Giessen / Germany HÜBNER CE www.huebner-giessen.com GIESSEN			
Drehzahlschalter + Frequenzgeber / Overspeed switch with encoder			
EGSH 41 KK/20P - FG 40-1024G-90G-NG			
S/N 123456	C/N 12345678	Bj./Y 2018	IP65
← EGS →		← FG →	
max. Drehzahl / max. speed 1800 rpm		Imp./U / CPR 1024	
Versorgungsspg. / Power supply 12-30 V DC, max. 3 W		Versorgungsspg. / Power supply 12-30 V DC	
Schalter / Switches S1/S2: max. 230 V / 250 mA AC/DC Diag: max. 30 V / 50 mA DC		Leerlaufstromaufnahme No-load current ca. approx. 50 mA bei 24 V	
Zertifiziert nach / Certified through IEC 61508 - SIL2 DIN EN ISO 13849 PLd		Ausgänge / Outputs HTL, max. 150 mA bei 24 V	

Example EGSH 41 KK – FG 40

The type plate is located on the side of the housing and contains the following information:

- Manufacturer, address
 - CE mark
 - Type, year of construction
 - Serial number (S/N)
 - Commission number (C/N)
 - Max. speed
 - Supply voltage:
 - Switching voltage / max. switching current
 - Certification
 - Degree of protection
- With integrated FG 40 includes
- Number of pulses
 - Supply voltage
 - No-load current
 - Outputs

3.2 Type key

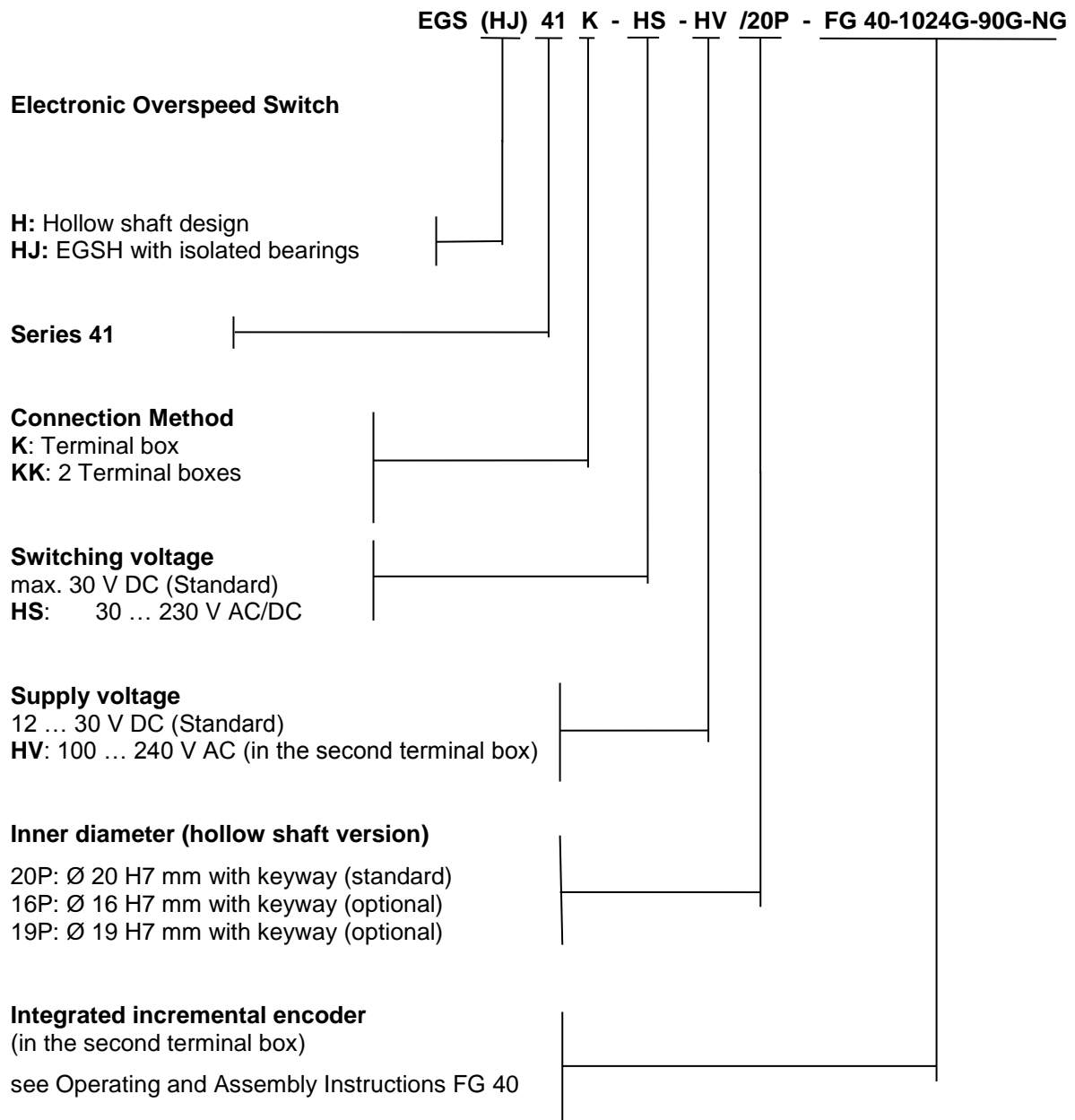

3.3 Electrical and mechanical data

3.3.1 Connected loads, environment

Specification	Value														
Supply voltage	12 ... 30 VDC														
Supply voltage (option HV)	100 ... 240 VAC														
Power consumption	max. 3 W														
Programmable switching speed (The max. switching speed = 0,9 x permissible speed see chapter 3.3.4)	0,5 ... max. 5400 rpm														
Switching accuracy (see chapter 6.1.3)	2%														
Switch S1, S2	0 ... 30 V DC / max. 500 mA Max. voltage drop at the closed switch 0,7V														
Switch S1, S2 (Option HS)	30 ... 230 V AC/DC / max. 250 mA Max. voltage drop at the closed switch 5V														
Derating: Y-Axis: Total switch current S1 + S2 [mA] X-Axis: Temperature [°C]	<table border="1"> <caption>Derating Graph Data</caption> <thead> <tr> <th>Temperature [°C]</th> <th>Total switch current S1 + S2 [mA]</th> </tr> </thead> <tbody> <tr> <td>-25</td> <td>500</td> </tr> <tr> <td>0</td> <td>500</td> </tr> <tr> <td>25</td> <td>500</td> </tr> <tr> <td>50</td> <td>500</td> </tr> <tr> <td>75</td> <td>~167</td> </tr> <tr> <td>90</td> <td>0</td> </tr> </tbody> </table>	Temperature [°C]	Total switch current S1 + S2 [mA]	-25	500	0	500	25	500	50	500	75	~167	90	0
Temperature [°C]	Total switch current S1 + S2 [mA]														
-25	500														
0	500														
25	500														
50	500														
75	~167														
90	0														
Switch diagnostic	0 ... 30 V DC / max. 50 mA														
Device temperature range	-25 ... +85°C														
Permissible relative humidity (operating)	15 ... 90%														

3.3.2 Electrical Outputs

Variant	Switching Contacts	Diagnosis-switch	Incremental Output	Supply Voltage	Connection Diagram See chapter 10.1
EGS(H) 41K	2	1	-	12 30 VDC	PN112-400
EGS(H) 41KK	4	2	-	12 30 VDC	PN112-400
EGS(H) 41KK – FG 40	2	1	6/8	12 30 VDC	PN112-400 + Connection diagram for FG40 see operating and assembly instructions FG40
EGS(H) 41KK - HV	2	1	-	100 .. 240 VAC	PN112-410 + PN112-420

3.3.3 Mechanical Data

Description		Data	
Vibration resistance		DIN EN 60068-2-6 / IEC 68-2-6 (10 ... 2000 Hz)	20 g (=200 m/s ²)
Shock resistance		DIN EN 60068-2-27 / IEC 68-2-27 (6 ms)	100 g (ca. 1000 m/s ²)
EGS 41	Max. encoder shaft load	F _{a max.} (axial) = 100 N F _{r max.} (radial) = 120 N	
	Shaft end	11j6 x 30 mm (standard) 14j6 x 30 mm (optional)	
	Weight	EGS 41 K EGS 41 KK	Approx. 3.3 kg Approx. 3.6 kg
EGSH 41	Weight	EGSH 41 K EGSH 41 KK	Approx. 4.2 kg Approx. 4.5 kg

3.3.4 Degree of protection

Degree of protection acc. to DIN EN 60529		Sealing	Permissible speed	Rotor moment of inertia	Breakaway torque
EGS 41	IP 65	standard	≤ 6000 rpm	approx. 510 gcm ²	approx. 6 Ncm
	IP 66	with labyrinth seal	≤ 6000 rpm	approx. 580 gcm ²	approx. 6 Ncm
	IP 66 / IP 67	with axial shaft seal	≤ 4000 rpm	approx. 510 gcm ²	approx. 8 Ncm
	IP 66 / IP 67	with radial shaft seal (for special applications, e.g. wet areas in rolling mills)	≤ 3000 rpm	approx. 510 gcm ²	approx. 9 Ncm
EGSH 41	IP 65	standard	≤ 4000 rpm (*) ≤ 3000 rpm	approx. 1175 gcm ²	approx. 10 Ncm
	IP 66	with labyrinth seal	≤ 4000 rpm (*) ≤ 3000 rpm	approx. 1325 gcm ²	approx. 10 Ncm
	IP 66	with axial shaft seal	≤ 2000 rpm	approx. 1175 gcm ²	approx. 25 Ncm
	IP 66	with radial shaft seal (for special applications, e.g. wet areas in rolling mills)	≤ 2000 rpm	approx. 1175 gcm ²	approx. 30 Ncm

(*) with isolated bearings – hybrid bearings –





NOTES!

The hollow shaft device EGSH 41 reduces the degree of protection to IP 65, if the cover plate is not mounted. At maximum speed the permissible ambient temperature will be reduced to 60°C.

4 Installation and commissioning

4.1 Safety instructions

	<p>WARNING!</p> <p>At assembly, dismantling and other work to the EGS(H) 41 the basic safety instructions to chapter 2 must be observed.</p> <p>The assembly and the dismantling of the EGS(H) 41 must only be carried out by qualified personnel!</p>
---	--

	<p>DANGER! NOTICE!</p> <p>Danger of death, serious physical injury and/or damage to property due to deactivation of safety functions, caused by an unstable shaft drive!</p> <ul style="list-style-type: none"> The system manufacturer must implement suitable design measures, so that the drive of the EGS(H) 41 is ensured at all times through the shaft and mounting (see chapter 4.2) of the EGS(H) 41 (fault exclusion). The specifications of DIN EN 61800-5-2:2008 "Adjustable speed electrical power drive systems, Safety requirements - Functional, Table D.16 – Motion and position sensors" must be observed. In general, the requirements and acceptance conditions for the complete system must be taken into account for mounting. If it is not possible to use a coupling for which fatigue and design strength calculations are available, a coupling must be used capable of withstanding 10 times the loads that occur during normal operations as stated in the data sheet. <p>For mounting the EGS 41, we recommend our specially designed mechanical safety components: clearance-free, torsionally rigid HKS5 coupling with fault exclusion (see chapter 4.8 coupling) and intermediate flange with fault exclusion.</p> <p>As the installation situation is application-dependent, the following notes are not exhaustive.</p> <ul style="list-style-type: none"> All fastening screws must be secured against unintentional loosening. In case of applications with low operating temperatures, increased values for the start-up torque result. This fact is to be considered when the assembling and wave drive is performed. A suitable coupling with positive connection must be used for the application. The coupling manufacturer's information and installation requirements must be observed. <p>In particular, you must ensure that:</p> <ul style="list-style-type: none"> the coupling is suitable for the possible axial and radial offset, as well as the permissible speed range. the coupling is suitable for the specified speed and the potential parallel, angular and axial offset, the coupling is not radially and axially loaded, the clamping screws are tightened with the torque defined by the coupling manufacturer and are secured against unintentional loosening, so that the coupling cannot slip on the drive shaft or onto the EGS(H) 41 shaft.
---	---

The electronic overspeed switch from the EGS(H) 41 series is a switching device designed to ensure the safety of machines, devices and systems in line with application requirements, and contribute towards the overall classification of a given safety category.

Inspection

Observe and adhere to all relevant regulations, guidelines and laws when utilising the EGS(H) 41 to monitor overspeeds in safety-relevant machines and systems; you should also inspect the device on a regular basis. Inspections must be recorded in a log book (please refer to the inspection schedule in Chapter 6.4.3).

Furthermore, we remind you of your obligation to adhere to the various country-specific laws, guidelines and standards. You must also observe the supplied operating and installation instructions that in addition to regulating safety and commissioning procedures for the device, individual components and the entire system also define regular inspection schedules (electrical and mechanical functional testing).

Personnel

Installation and commissioning must be carried out by skilled technical staff only.

4.2 Technical information



NOTES!

Do not use a hammer or similar tool when installing the device due to the risk of damage occurring to the bearings or coupling!

Ambient temperature

The max. permissible ambient temperature depends on the speed and degree of protection of the device, the signal frequency, the length of the signal cable and the place of installation (please refer to Chapter 3.3).

Degree of protection

To fulfill degree of protection requirements the diameter of the connection cable must correspond to that of the cable gland (please refer to Chapter 9 dimension drawings)

Deep groove ball bearings

The electronic overspeed switch EGS(H) 41 is fitted with maintenance-free, greased "for-life" deep groove bearings. (Bearing life see chapter 6.1.5). Bearings must be changed by the manufacturer only. Opening the encoder renders the guarantee null and void.

Screw retention

We recommend using Loctite® 243 threadlocker (medium strength) on all fastening screws to prevent loosening.

4.3 Required tools

- Spanners: 10 mm, 13 mm, 22 mm, 24 mm
- Allen keys: 2 mm, 3 mm, 5 mm
- Flat-blade screwdrivers:
- Assembly grease (acid-free)
- Loctite® 243 (medium strength threadlocker)

4.4 Mounting preparations

1. Ensure all accessories are available (please refer to Chapter 9 dimension drawings).



NOTES!

Fastening screws and earth cable are not included in the range of supply.

2. Preparing the place of attachment: Clean the (motor) shaft, centering, bolting surfaces and fastening threads; check for damage. Repair any damage!

4.5 Mounting B5 type (flange)

	<p>NOTES!</p> <p>For a mounting example please refer to dimension drawing HM 17 M 111646 (chapter 9).</p> <ul style="list-style-type: none"> • The installation described below is offered as an example only and may vary according to the coupling and flange type. It is essential to observe the specific instructions provided by the manufacturer of the coupling. • You must be able to mount the coupling without force. Ream out the bores of used couplings, if necessary. • If possible, fit the intermediate flange (4) in a manner that ensures the screwed sealing plug (16) points downwards! • If possible, fit the device in a manner that ensures the cable gland points downwards Exchange the position of the cable gland (19) and the blanking plug (16), if necessary. • To carry out step 9, it may be necessary to turn the drive shaft (1) to the correct position.
---	---

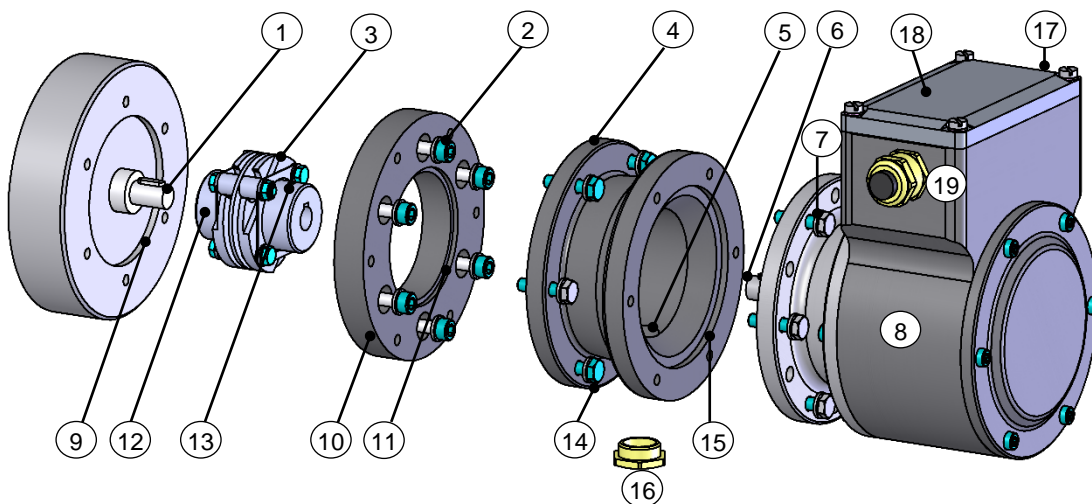



Fig. 4.1 Example construction type B5

1. Grease the motor shaft lightly (1).
2. Fit coupling (3) onto motor shaft (1).
3. Secure the coupling hub on the drive shaft (1) using a grub screw or a screw (12) (depending on the coupling type).
4. Fasten the intermediate disc (10) on the drive side by using of the fastening screws and washers (2).
5. Fasten the intermediate flange (4) to the intermediate disc (10) by using the fastening screws(14) and washers (14).
6. Grease the overspeed switch shaft lightly (6).
7. Fit the overspeed switch (8) into both the centering (15) and coupling hub (13) at the same time.

8. Secure the overspeed switch with 4 - 6 screws (7) and washers evenly distributed around the circumference of the flange (4).
9. Remove the sealing plug (16) from the access bore (5) to the coupling.
10. Secure the coupling hub on the overspeed switch shaft with a grub screw or screw (13) (depending on the coupling type).
11. Close access bore in the intermediate flange (4) for coupling with the sealing plug (16).

4.6 Mounting B35 type (flange and foot)

	<p>NOTES!</p> <ul style="list-style-type: none"> • B35 type overspeed switches can be attached by means of a flange (B5, please refer to chapter 4.5) or foot (B35): • For a mounting example please refer to dimension drawing HM 17 M 111652 (chapter 9.1.2). • The assembly procedure described below is offered as an example only and may vary according to the type of coupling. It is essential to observe the specific instructions provided by the manufacturer of the coupling. • You must be able to mount the coupling (3) without force! Ream the bores of used couplings, if necessary! • Angle misalignment and parallel displacement between the drive shaft (1) and the overspeed switch shaft are mounting errors and should be kept as small as possible. <p>Mounting errors</p> <ul style="list-style-type: none"> • Cause radial forces to act on the overspeed switch shaft. • Reduce the service life of the bearings and the coupling. • Degrade the quality of the signals (harmonic content).
---	--

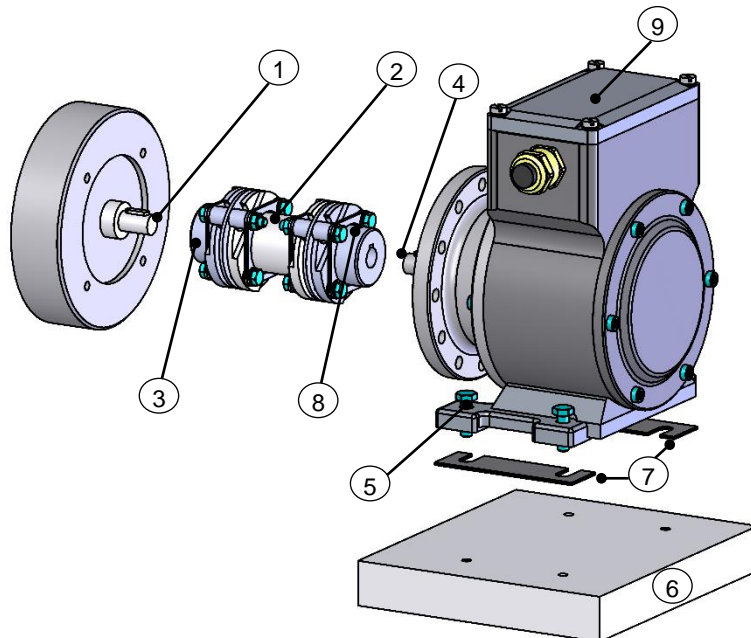

Fig. 4.2 Example construction type B35

1. Grease the motor shaft lightly (1).
2. Secure the coupling hub on the motor shaft (1) with a grub screw or cheese head screw (3) (depending on the coupling type).
3. Grease the overspeed switch shaft lightly (4).
4. Align the overspeed switch shaft (4) to the drive shaft (1) and insert into the coupling hub.
5. Fasten overspeed switch foot with 4 screws (5).

**NOTES!**

Use shims (7) to achieve the correct vertical alignment to the base plate (6).

Observe information in Chapter 4.7 about mounting errors and max. permissible mounting tolerances!

6. Secure the coupling hub on the overspeed switch shaft with a grub screw or with a screw (8) (depending on the coupling type).

**NOTES!**

To avoid injuries by turning parts, the coupling must be provided before introduction with a suitable cover.

4.7 Mounting tolerances for Construction Type B5 and B35



NOTES!

Angle misalignment and parallel displacement between the (motor) shaft and the overspeed switch shaft are mounting errors and should be kept as small as possible.

Mounting errors

- Cause radial forces to act on the encoder shaft.
- Reduce the service life of the bearings and the coupling.
- Degrade the quality of the signals (harmonic content).

4.8 Coupling

We recommend our zero-backlash, torsion-resistant coupling HKS5 with fault exclusion to attach the EGS 41.

The coupling meets the following requirements

Description		Value	
shock resistance	(DIN EN 60068-2-27 (6 ms))	100 g	
vibration resistance	(DIN EN 60068-2-6 (8,7 ... 2000 Hz))	20 g	
torque		3 Nm	
temperature range		-25° ... +85° C	
max. speed		6000 rpm	
mounting accuracy	<u>HKS 5 /</u> <u>HKSI 5:</u>	axial offset:	± 1 mm
		angular:	0,5°
	<u>HKDS 5 /</u> <u>HKDSI 5:</u>	axial offset:	± 1,5 mm
		radial offset:	± 0,5mm

4.9 Attaching additional devices



NOTES!

Overspeed switch design types B5/B14 and B35/B14 have a second shaft extension with integrated coupling half (1) and a B14 type flange (2) on the non-drive end, onto which it is possible to fit an additional device with a B5 flange, for example an incremental encoder, absolute shaft encoder or an overspeed switch. A second coupling half with elastomer ring (5, Figure 4), which is available as an accessory, is required to fit an additional device.

This design option makes it possible to combine up to three devices.

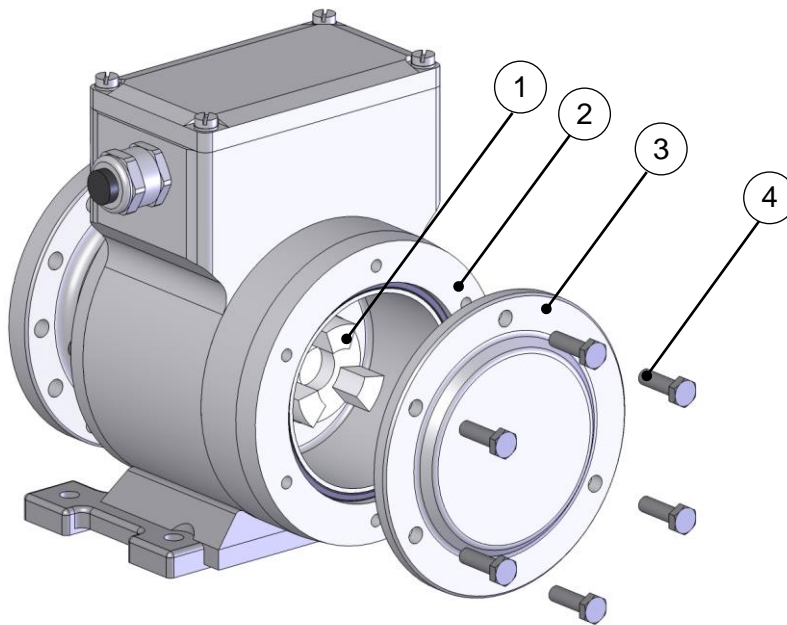

Fig. 3

When supplied ex works the second shaft end is protected by a cover plate (3) secured with 6x M6x20 hexagon head screws (4).



CAUTION!

Do not remove the housing cover secured with Torx screws! These devices are not equipped with a second shaft end.

1. Loosen the hexagon-head screws (4).



NOTES!

The fastening screws (4) can be used later to secure the additional device (7).

2. Remove the cover plate (3).



NOTES!

Ensure no liquids or dirt are allowed ingress into the device when the cover plate is removed.



WARNING!

If no second device is added ensure the cover plate is fitted to protect and cover the second shaft end. This prevents the risk of injury and maintains the protection class rating of the device. Replace the cover plate if there is any delay when fitting a second device.

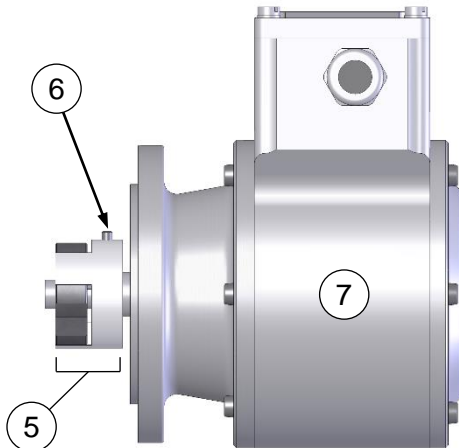

Fig. 4

- Slide on the coupling half (5) with elastomer ring up to the collar of the shaft of the additional device (7), and secure by tightening the grub screw (6).



NOTES!

The correct distance between both coupling halves has now been set.

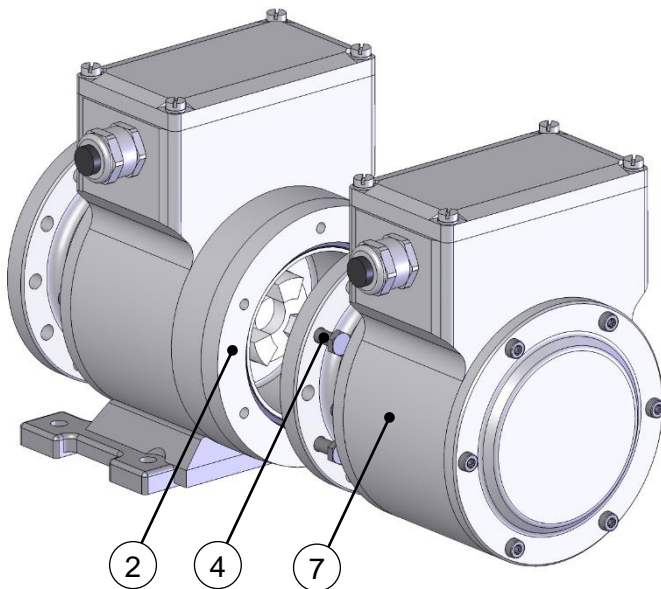

Fig. 5

- Fit the additional device (7) to the B14 flange (2) of the overspeed switch.

Secure the additional device (7) with 6x M6x20 – 8.8 hex head screws. It is possible to use the fastening screws (4) from the cover plate (3) for this purpose.

4.10 Mounting hollow-shaft type overspeed switches

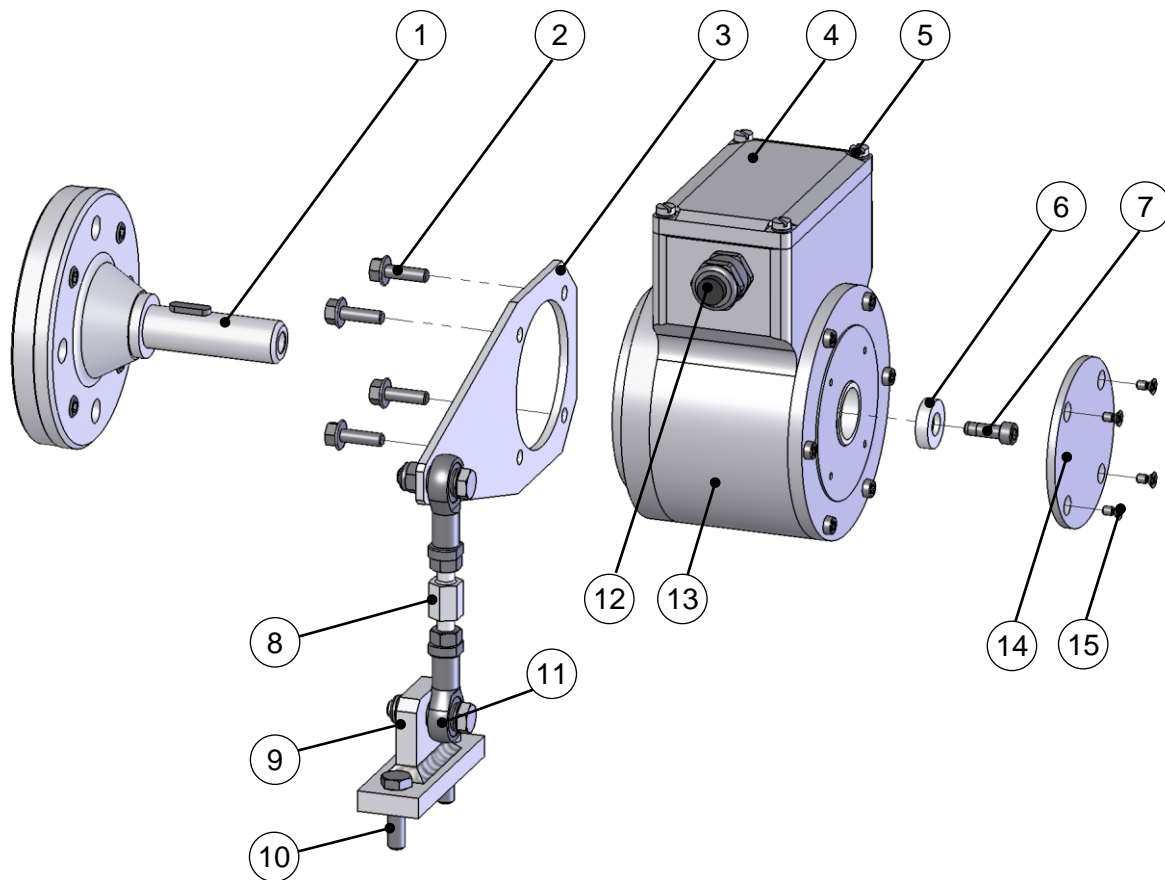

Fig. 6

1. Mount adapter shaft (1) and align using dial gauge.

NOTES!

The maximum radial run-out of the adapter shaft is 0.05 mm.

If necessary, use the ball thrust adjustment screw to align the adapter shaft. Secure ball thrust screws with Loctite® 243. Remove unused ball thrust screws or secure with Loctite® 243. Max. tightening torque for M12 approx. 25 Nm, for M16 approx. 35 Nm.

Use parallel keys to DIN 6885.

Please also observe the supplement data sheet *Mounting accuracy for hollow shaft encoders*.

You should also observe the Installation instructions supplied with the adapter shaft when installing!



2. Grease the adapter shaft lightly.
3. Secure the torque bracket (3) to the hollow-shaft device (13) with 4 tensilock screws (2).

NOTES!

When fitting to the device is possible to align the torque bracket in four different directions. If possible fit the device in a manner that ensures the cable gland points downwards! Exchange the position of the cable gland (12) and the blanking plug on the opposite side, if necessary.



4. Mount the hollow-shaft device to the adapter shaft.



NOTES!

The hollow shaft device must slide easily onto the adapter shaft. Never use excessive force, otherwise the bearings may be damaged. If necessary, use emery cloth or a file to produce a better fit between the adapter shaft and the key. Do not allow the device to hit hard against the collar of the shaft.

5. Secure the hollow-shaft device with the aid of the axial tensioning disc (6) and a hexagon socket head cap screw (7).



NOTES!

The axial tensioning disc is supplied with several hexagon head socket cap screws of different lengths. To select the suitable hexagon head socket cap screw please refer to the dimensioning drawings in Chapter 9.

The hexagon head socket cap screws are coated with a microencapsulated adhesive as locking agent.

6. Fit the cover (14) and secure with four countersunk screws (15) to seal the hollow-shaft device.
7. Fastening the torque bracket:

Ideally, the bracket arm (3) should be mounted at an angle of 90° to the link rod (8).

Fastening without base plate:

Secure the link rod head (11) of the link rod (8) to a fixed point (for example on the motor housing).

Fastening with base plate:

Secure the base plate (9) to a fixed point with two hexagon head screws (10) – (for example on the motor housing or the foundations).



NOTES!

Once fitted the link rod must rotate easily around the link rod heads! Failure to observe this point may result in damage to the bearings!



NOTES!

The link heads are maintenance free. However, ensure they remain free from soiling and paint!

4.11 Dismantling

4.11.1 Safety instruction

Personnel

Dismantling must be carried out by skilled technical staff only.



Observe the safety instructions contained in Chapter 2 when dismantling the device!



Do not use a hammer or similar tool when installing the device due to the risk of damage occurring to the bearings or coupling!

4.11.2 Dismantling the encoder type B5 and B35

To dismantling the encoder follow the instructions given in Chapters 4.5 and 4.6 in the reverse order.

4.11.3 Dismantling hollow shaft type overspeed switches

1. Dismantle the hollow shaft device follow the instructions in Chapter 4.10 in the reverse order.

NOTES!

Use the withdrawal device D-53663 (available as an accessory) if you are unable to remove the device manually from the adapter shaft after having removed the axial tensioning disc!



Special tool: Withdrawal device D-53633

Using the withdrawal device, which is screwed into the withdrawal thread M25 x 0.75 of the hollow shaft allows you to remove the overspeed switch from the adapter shaft without risking damage to the bearings.

4.12 Electrical connection and start up



NOTES!

When integrated, please refer to the separate FG 40 Operating Instructions.



NOTES!

You must observe applicable EMC guidelines when routing cables!

4.12.1 Preparing cables

1. Strip cable insulation.
2. Crimp wire-end ferrules.

4.12.2 Electrical connection

1. Open the terminal box cover (18 Fig. 4.1).



CAUTION!

Do not allow moisture to enter the terminal box when the cover is open!

2. Remove the cap of the cable gland (19 Fig.4.1).
3. Feed the cable into the terminal box trough the cable gland.
4. Tighten the cable gland and blanking plugs using a spanner.



NOTES!

Prior to delivery cable glands and blanking plugs are tightened finger tight only. To ensure that the terminal box is reliably sealed tighten all cable glands and blanking plugs before starting up for the first time.

5. Use a spanner to tighten the cable gland until the cable is securely clamped and properly sealed.



NOTES!

Prevent lateral pulling forces acting on the cable and plugs so as not to impair the degree of protection of the cable gland.

6. Connect the supply voltage and signal cable (please refer to the connection diagrams, Chapter 10).
7. Close the terminal box cover.



NOTES!

Option HS: Use the cable lug supplied for the protective conductor connection.



NOTES!

Before closing the terminal box cover check and if necessary clean both seal surfaces and the gasket.



CAUTION!

Ensure when closing the terminal box cover that no cable becomes jammed.

Secure earth cable to earth terminal (20, Fig. 4.1, mounting example B5).

5 Structure and function

5.1 Brief description

The electronic overspeed switch EGS(H) 41 is a safety speed switch (certified to EN 61508 SIL2 and EN ISO 13849-1 PLd). Its parameters are configured using a PC with a Windows® operating system (Version XP Vista and 7) and the supplied programming software EGS41Pro. The physical interface is a USB port.

The electronic overspeed switch has 3 switching outputs, 2 for speed monitoring and one for diagnosis. Semiconductor switches perform the switching function. The switches are monitored for temperature.

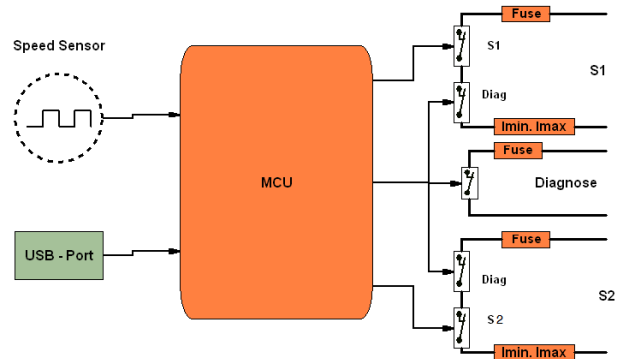

The switches are normally open contacts. When EGS(H) 41 is functioning perfectly and operating voltage is applied, the diagnosis switch closes. Switching contacts S1 and S2 are switched depending on the adjusted speed parameters. From now on, the switches act as normally closed contacts, as shown in the block diagram. A separate upstream diagnosis switch is connected in series for safe switching off of switching contacts S1 and S2.

The switching outputs are electrically isolated from the electronic components and PC interface.

Functions:

Speed switches:

Two safety, electrically isolated switching contacts are available for monitoring speed. Each switching contact can be programmed for overspeed and underspeed, with corresponding switch-back speeds. The "rotation-dependent" setting can be used to give every switching point different switching speeds, depending on the direction of rotation.

⇒ For detailed information refer to the separate configuration manual.

Diagnosis: The diagnosis feature automatically checks the hardware and software modules relevant to the safety function. A detected malfunction is shown by contacts S1 and S2 of the diagnosis switch opening.

Over current detection (Imax): The switch is monitored and over current registered for every switching channel. Over current detection is triggered with 1.5x max. current, regardless of which switching channel the over current occurs in. The device is set to a safe condition when over current occurs. The switching current is registered and evaluated for both current directions. Via PC-software the delay of the switching outputs is programmable.

Switch monitoring (Imin): Switch monitoring monitors the condition of the switching contacts. A closed contact is detected when the switching contact current is >5mA. This is checked for both current directions.



NOTES!

Switch monitoring requires a minimum load current of 5 mA.

6 Functional safety

6.1 Device data

6.1.1 Characteristic safety values

Characteristic safety values	
Safety class / standard	<ul style="list-style-type: none"> • SIL2 to EN 61508 • Performance level 'd' to EN ISO 13849-1 • Category 2
System structure	1 channel with diagnostics (1oo1D)
Device type	Type B (complex components)
Hardware fault tolerance (HFT)	0
Type of operating mode	'High demand' to EN 61508 (high demand rate)
Probability of a dangerous failure per hour (PFH _d)	1,66 x 10 ⁻⁷ [1/h]
Failure rate: safe detected (λ _{SD}) safe undetected (λ _{SU}) Dangerous detected (λ _{DD}) Dangerous undetected (λ _{DU})	λ _{SD} : 2,82 x 10 ⁻⁶ [1/h] λ _{SU} : 4,41 x 10 ⁻⁷ [1/h] λ _{DD} : 1,53 x 10 ⁻⁶ [1/h] λ _{DU} : 1,66 x 10 ⁻⁷ [1/h]
Mean time to a dangerous failure (MTTF _d)	67,1 years (high)
Diagnostic coverage on average (DC _{AVG})	90 % (medium)
Proportion of safe failure fraction (SFF)	97,0 %
Service life or proof test interval to EN 61508	10 years Thereafter the components must be replaced with new components
Safe state	<ul style="list-style-type: none"> • Switch S1 open • Switch S2 open • Diagnostic switch open.
Safety function	Safe overspeed switch-off switch S1 and switch S2

6.1.2 Timing

Concerning the process security of the application the chapter 7.4.3.2.5 of the EN 61508-2 is also to be considered.

Power-on time T_{Pw}

After the power supply is turned on initial internal diagnostic checks are carried out before the device is ready for operations.

The power-on time is approx. 1.6 s.

Diagnostics time T_{Diag}

The **base diagnosis time** amounts to 450 ms. If a diagnosis is faulty this diagnosis is explained once more (postmeasurement).

The max. postmeasuring time amounts to 500 ms.

If the postmeasurement is also faulty, the device is moved into the sure state.

Base diagnosis time 950 ms.

The **temperature diagnosis time** = 3x base diagnosis time.

It is recognised temperature excess or temperature undercut, the measurement is repeated after 500 ms.

If the postmeasurement is also faulty, the device is moved into the sure state.

Temperature diagnosis time: 1850 ms

Diagnosis times dependent on speed

The times for impulse number and zero impulse diagnosis are dependent on speed and add themselves at the base diagnosis time. The additional times T_z calculate themselves as follows:

$$T_z = \frac{60000}{n} \text{ ms}$$

n : current speed [rpm]

The maximum time for T_z is limited to 1 second.

If the diagnosis is not concluded in this time, this is finished and begins in the next diagnosis interval once more.

Switching time T_{Sw}

The switching time T_{Sys} of the contacts S1 and S2 consists of speed measuring time system time and the switching time of the switch and is max. 3 ms

In addition, the optionally adjustable switch delay T_{Delay} must be added.

$$T_{Sw} = T_{Sys} + T_{Delay}$$

6.1.3 Switching accuracy

The switching accuracy Δn is made up of:

- Switching time T_{Sw} : ≤ 3 ms
- Measuring accuracy ΔF (Error in the determination of speed): ≤ 2 %
- Measuring angle φ : approx. 1°

The following formula arises from it:

$$\Delta n = \sqrt{n_0^2 + \frac{\alpha \cdot \varphi}{3}} + \alpha \cdot \frac{T_{Sw}}{1000} + \Delta F \cdot n_0 - n_0$$

Δn : max. switching failure [rpm]

n_0 : switching point [rpm]

α : acceleration [rpm / s]

φ : measuring angle [$^\circ$]

T_{Sw} : switching time [ms]

6.1.4 Safe state

The safe state of the device is: all switches open.

6.1.5 Service life of the bearings

Calculations pertaining to the service life were carried out using data from the manufacturer of the bearings.

The stated service lifetimes are based on the modified rating life L_{10} in accordance with DIN ISO 281. That means, the probability that the bearings will attain or exceed the specified service lives is 90%.

Device type	Speed	Hours	Years
EGS 41	500 rpm	> 85000	> 10
	1000 rpm	> 85000	> 10
	3000 rpm	> 35000	> 4
	6000 rpm	> 18000	> 2
EGSH 41	500 rpm	> 85000	> 10
	1000 rpm	> 85000	> 10
	3000 rpm	> 85000	> 10
	4000 rpm (*)	> 85000	> 10

(*) with isolated bearings not possible

The following factors influence the service life of the bearings

- Operating temperature
- Mechanical loads from vibration and shock
- Drive dynamics
- The influence of transport and storage (bearing grease ageing)
- Installation errors

6.2 Intended use

The electronic overspeed switch EGS(H) 41 has been designed and constructed exclusively for the intended use described here.

Series EGS(H)41 overspeed switches are used for safety overspeed monitoring (programmable), for instance of electrical and mechanical drives, hoisting gear, and conveying machines.

The switching signal of the EGS (H) 41 (opening of the switch contact) may be used, for example in a higher-level, safety-oriented control or directly be used in a safety chain (eg. contactor circuit) to establish a safe condition, eg. the shutdown of plant components.

Claims of any type due to damage arising from non-intended use are excluded; the owner bears the sole responsibility for non-intended use.

6.3 Improper use

- Do not use the device in potentially explosive areas.
- The device must not be subjected to mechanical loads in addition to its own weight and unavoidable vibration and shock loads that arise during normal operations.

Examples for non-permitted mechanical loads (incomplete list):

- Fastening transport or lifting tackle to the device, for example a crane hook to lift a motor.
 - Fastening packaging components to the device, for example ratchet straps, tarpaulins etc.
 - Using the device as a step, for example by people to climb onto a motor.
- It is not permitted to use the device in locations higher than 3000 m above sea level.

6.4 Inspections

6.4.1 Safety instructions personnel



WARNING!

Skilled technical staff only are permitted to inspect the device and its installation. Observe the safety instructions contained in **Chapter 2** when inspecting or working on the device!

6.4.2 Maintenance information

The device is maintenance-free. However, to guarantee optimum fault-free operations we recommend that you carry out the following inspections.

The inspection work described in this section must be carried out by skilled technical staff only. We remind you of your obligation to observe and adhere to all operating and owner-relevant accident prevention regulations, laws regarding the safeguarding of machinery and plant as well as application and country-specific regulations, laws and standards.

6.4.3 Inspection schedule



NOTES!

No interventions other than the cyclic tests described in the test schedule are necessary on the device. Any intervention on the device renders all guarantee claims null and void!

Interval	Inspections
Yearly	Inspect the coupling for damage and ensure it is free of play
	Ensure the fastening screws are properly tightened
	Ensure cable connections and connection terminals are properly tightened
	Check the torque bracket (applies to hollow shaft devices only): check link heads can move freely. You must be able to move the link rod manually. If it proves difficult to move, lightly oil the link rod heads or apply lubricant spray.
	Test the switch (See chapter switch test in the separate Configuration manual).
After approx. 16 000 – 20 000 hours of operation or higher levels of continuous load	Check deep groove ball bearings for noise, running smoothly. Bearings must be replaced by the manufacturer only.

6.5 Fault table

Faults	Possible cause	Remedy
Diagnosis switch does not close	No supply voltage <u>Control:</u> LED in terminal box does not shine	Check connection cable and supply voltage
	A mistake was recognised	Select the mistake memories with EGS41Pro and initiate possible suitable parking measures. Afterwards put back the mistake. Listing of the single mistakes see mistake table. (chapter 6.6)
Moisture in the terminal box	Soiled gasket or seal surfaces of terminal box cover	Clean gasket of terminal box cover and seal surfaces
	Damaged gasket of terminal box cover	Replace gasket of terminal box cover
	Cable gland/blanking plug not tightened	Tighten cable gland/blanking plug
	Unsuitable cable for cable gland	Use suitable cable and cable glands

Contact Hubner-Service (page 2) if none of the remedies listed above provides a solution!



NOTES!

If an incremental encoder is integrated please also refer to the fault table in the separate FG 40 Operating and Assembly instructions.

6.6 Error table

Error message [Error Number]	Description
Dg_Intern [FFxx]	Device error
Dg_Iov [0601, FE01]	Overcurrent in switch 1 or switch 2
Dg_Sw1Dr [0602, FE02]	Broken wire switch 1
Dg_Sw2Dr [0603, FE03]	Broken wire switch 2
Dg_TempMain [0604, FE04]	Overtemperature in device
Dg_TempKK [0605, FE05]	Overtemperature in switch
Dg_Temp230V [0606, FE06]	Overtemperature in power supply unit „option HV“
Dg_ExtOv [0607, FE07]	Max. permissible supply voltage exceeded
Dg_n_Fatal [0608, FE08]	Non-permissible high speed
Dg_ExtUv [0609, FE09]	Below lowest permissible supply voltage
Error [FExx]	Error
FatalError [FFxx]	Fatal error

Error category:

Error	Fatal Error
The switches S1, S2 and Diag will be opened. <ul style="list-style-type: none"> To reset to the normal state interrupt the power supply or click 'Delete error' in the software 'EGS41Pro'. 	The switches S1, S2 and Diag will be opened. <ul style="list-style-type: none"> To reset to the normal state click 'Delete error' in the software 'EGS41Pro'.

The device enters a 'safe state' in the event an error or fatal error occurs. In addition, the error causing the problem is displayed.

7 Replacement parts

The replacement parts listed below can be obtained via the service address on page 2.

Replacement Part	Comment
Cover	Cover for the 2 nd shaft end or for the hollow shaft bore (NDE)
Axial tensioning disk/ring	For hollow shaft design
Terminal box – screw plug	To seal unused cable gland threads
Cable gland	M20x1,5
Terminal box cover	Including flat seal and screws
Feather key	Specify shaft dimensions or feather key dimensions
Programming cable and software	
Screw plug	To close of the access to the coupling



NOTES!

When ordering replacement parts always specify the serial number of the device!

8 Transport, packaging and storage

8.1 Safety information concerning transport



CAUTION!

Material damage caused by improper transport!

Observe the symbols and information on the packaging:

- Do not throw - risk of breakage
- Keep dry
- Do not expose to heat above 40 °C or direct sunlight.

8.2 Goods inward inspection

Check the delivery immediately upon receipt for transit damage or short delivery.

Inform the carrier immediately on receipt if you determine that damage has occurred during transit (take photos as proof).

8.3 Packaging (disposal)

The packaging is not taken back; dispose of according to the respective valid statutory provisions and local regulations.

8.4 Storing packages (devices)



Keep dry

Keep packages dry and free from dust; protect from moisture.

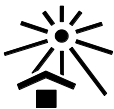

Protect against heat

Protect packages from heat above 40 °C and direct sunlight.

If you intend to store the device for a longer period of time (> 6 months) we recommend you use protective packaging (with desiccant).



NOTES!

Turn the shaft of the device every 6 month to prevent the bearing grease solidifying!

8.5 Returning devices (repairs/goodwill/warranty)

The devices which have got into contact with radioactive radiation or radioactive materials will not be taken back.

The devices which have got into contact with possibly noxious chemical or biological substances must be decontaminated before the return.

They must also be accompanied by a safety clearance certificate.

8.6 Disposal

The manufacturer is not obligated to take back electronics waste. The device consists of hybrid components, and in part must be disposed of as special waste (electronic scrap) according to country-specific legislation.

Local municipal authorities or specialized disposal companies provide information on environmentally responsible disposal.

9 Dimension drawings

Further dimension drawings on our Website or on request. (See service address on page 2).

9.1 EGS 41 dimension drawings

9.1.1 Construction type B5 (flange)

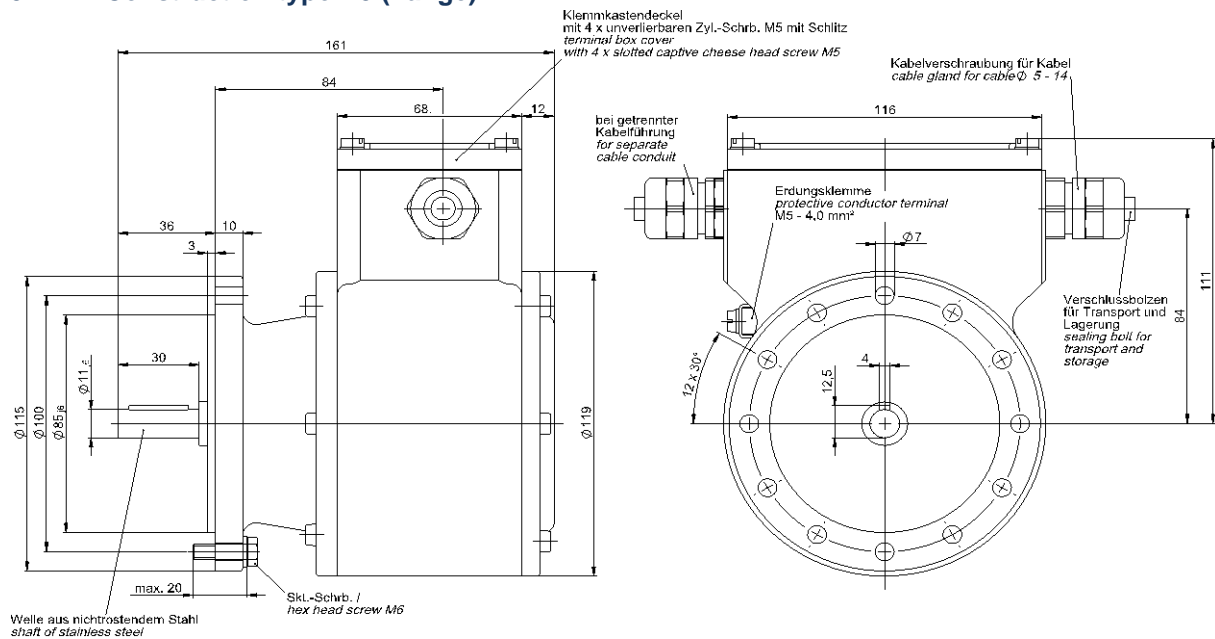

EGS 41 K

HM 09 M 102 520

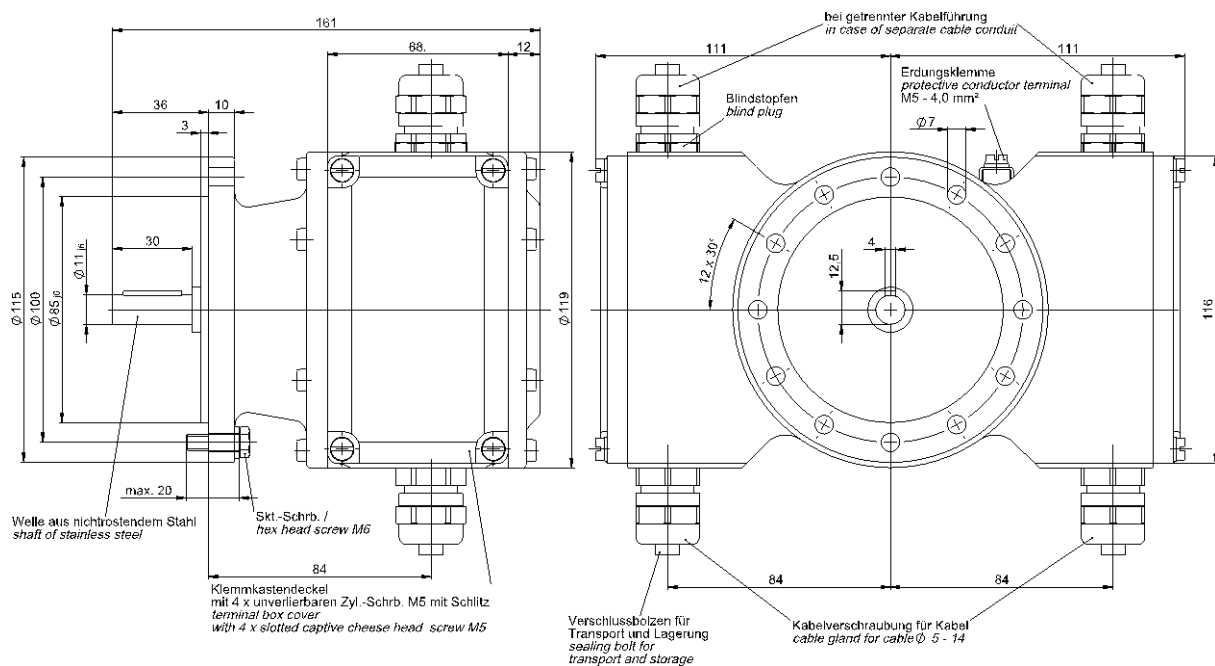

EGS 41 KK

Redundant version

HM 09 M 102 522a

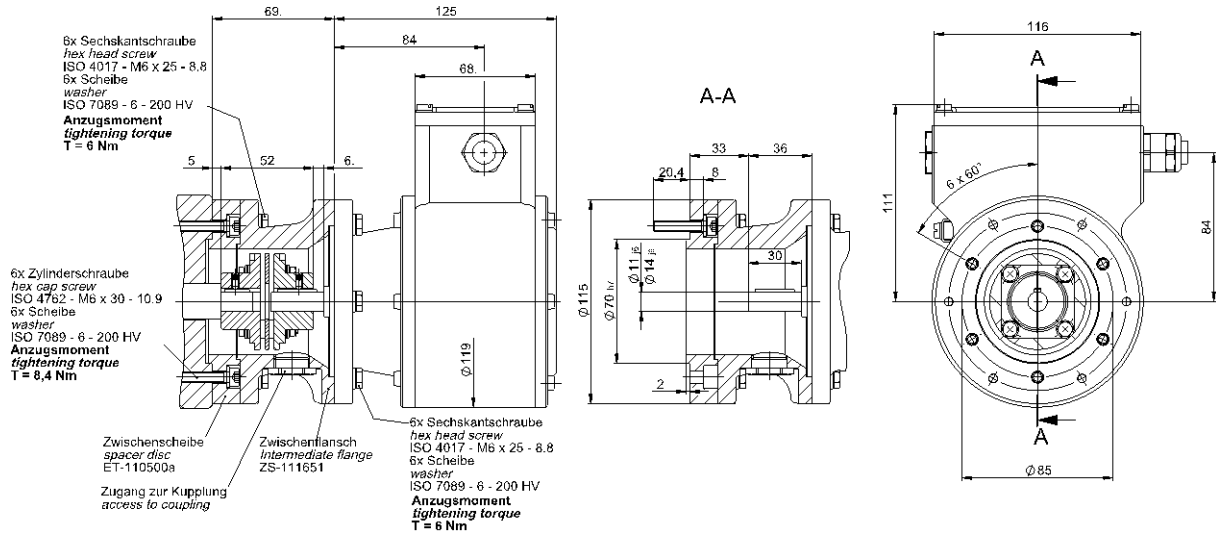

EGS 41 K

Mounting example for Construction type B5
with spacer flange and coupling HKS 522

HM 17 M 11646

9.1.2 Construction type B35 (flange and foot)

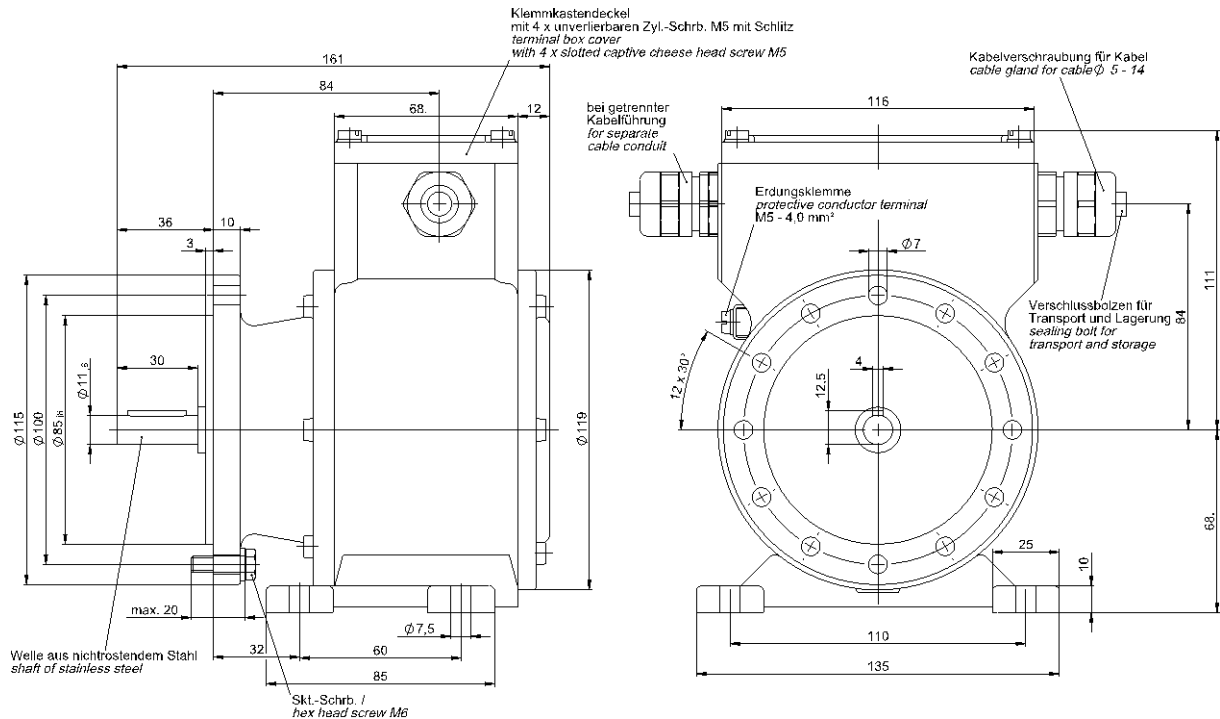

EGS 41 K

HM 09 M 102 521

Electronic Overspeed Switch EGS(H) 41

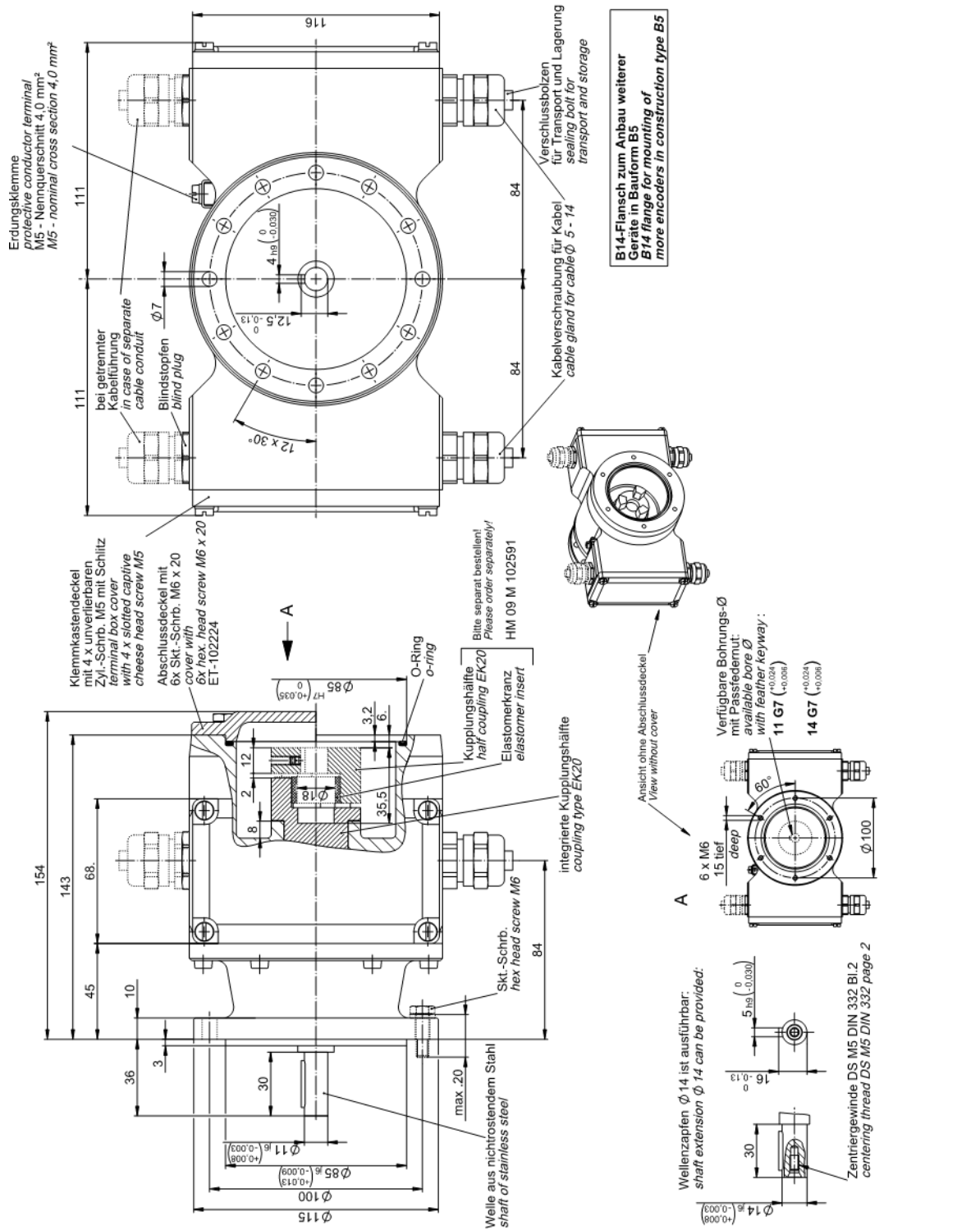

EGS 41 KK

Redundant version

HM 09 M 102 526

9.3 EGS(H) 41 – dimension drawings

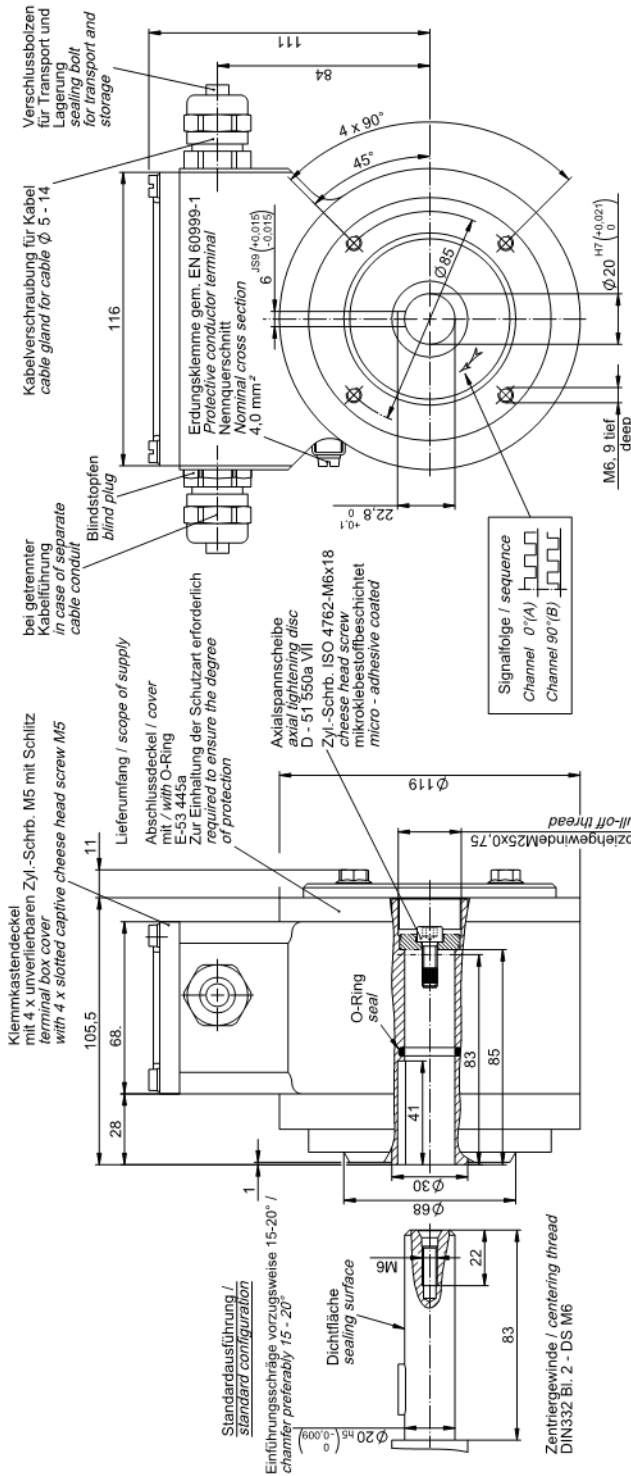

Abziehvorrichtung nach D - 53 663-1a
nur nach Bestellung!
pull-off device acc. to D - 53 663-1a
optional!

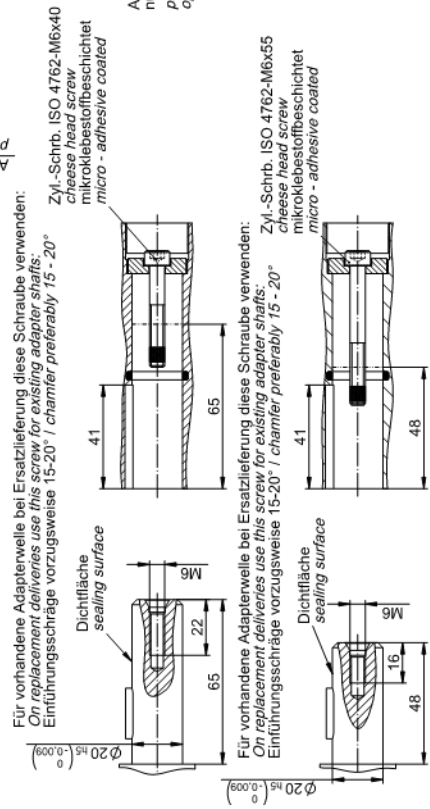

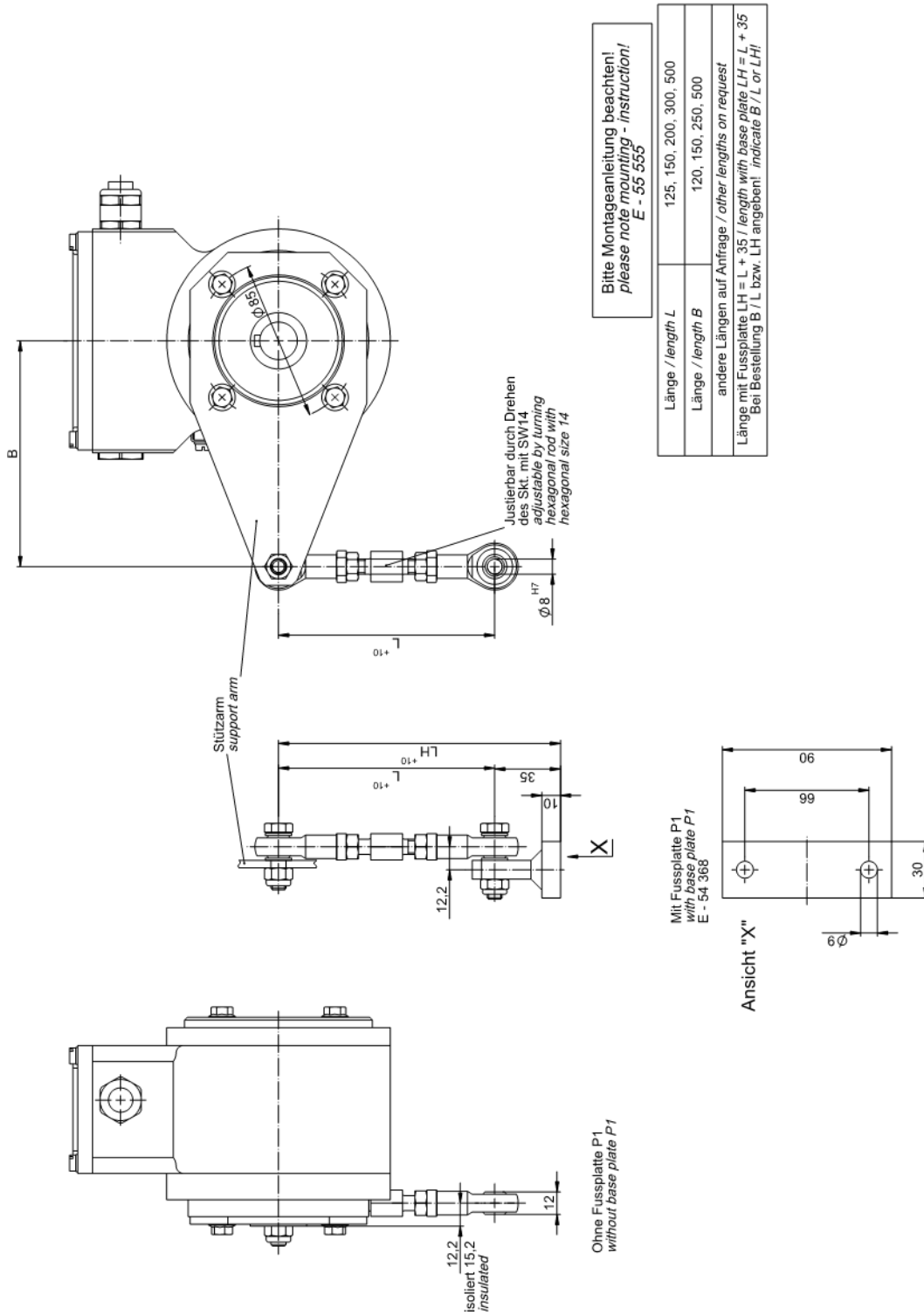

EGSH 41 K

Torque bracket

HM 09 M 102 203a

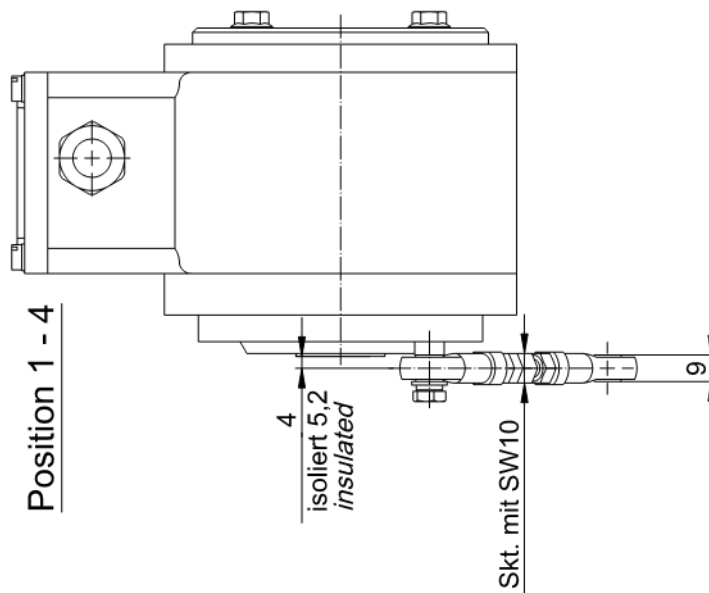
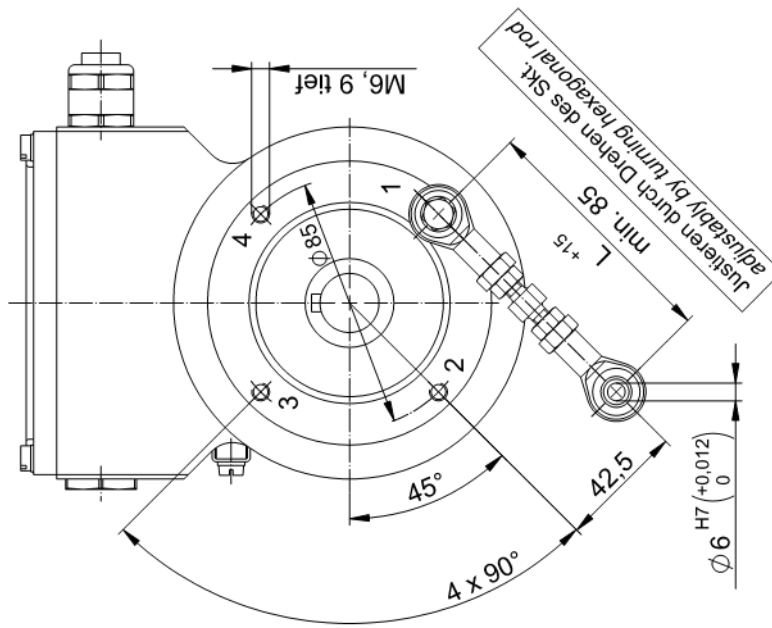

Länge / Length L	100; 125; 150; 200
<i>andere Längen auf Anfrage / other lengths on request</i>	

10 Connection Diagram

10.1 Connections

The connection boxes for the electronic overspeed switches are fitted with cable glands for cable diameter 5 – 14 mm. Fitting cables must be chosen in order to comply with the degree of protection requirements. (chapter 4.12).

Clamp Area of the connection clips 0,2 up to 1,5 mm.

Please take note of the connection diagrams.

PN 112 – 420

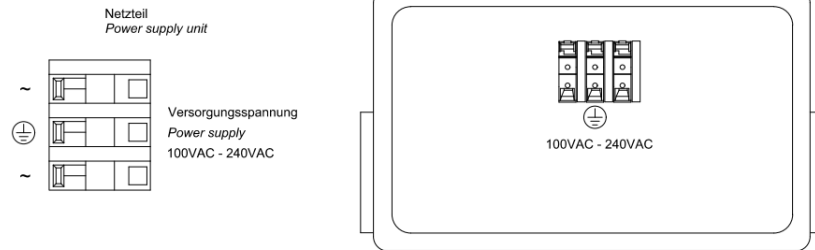

PN 112 – 400

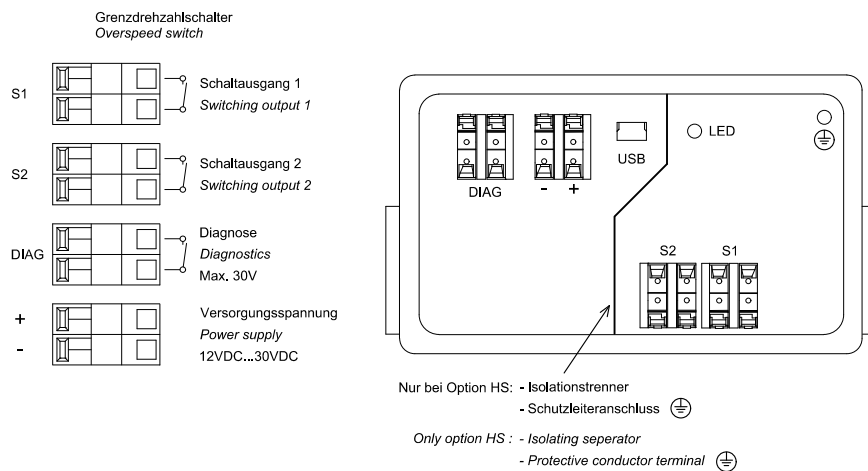

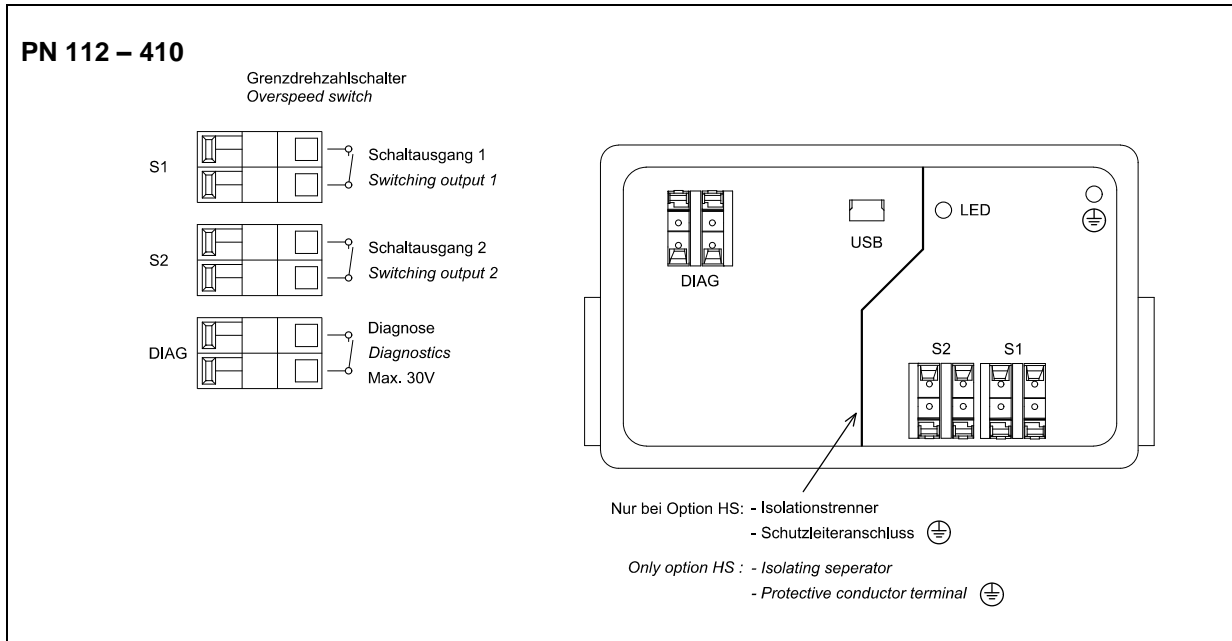

NOTES!

With integrated Encoder see further connection diagrams in Operating and Assembly Instructions FG 40.

11 Certificate



**ZERTIFIKAT
CERTIFICATE**

Hiermit wird bescheinigt, dass die Firma / *This certifies, that the company*

Johannes Hübner Fabrik elektrischer Maschinen GmbH
Siemensstraße 7
35394 Gießen
Deutschland

berechtigt ist, das unten genannte Produkt mit dem abgebildeten Zeichen zu kennzeichnen.
is authorized to provide the product mentioned below with the mark as illustrated.

Fertigungsstätte:
Manufacturing plant: Johannes Hübner
Fabrik elektrischer Maschinen GmbH
Siemensstraße 7
35394 Gießen
Deutschland

Beschreibung des Produktes:
(Details s. Anlage 1)
Description of product:
(Details see Annex 1) Grenzdrehzahlschalter EGS41
Overspeed Switch EGS41

Gepprüft nach:
Tested in accordance with: EN ISO 13849-1:2008, PL 'd'
EN 61508:2010, SIL 2

Registrier-Nr. / *Registration No.* 44 207 14153105
Prüfbericht Nr. / *Test Report No.* 3516 9692 / 12207408292/ 12207403031/
11207392422/ 10207356778
Aktenzeichen / *File reference* 8000453279

Gültigkeit / *Validity*
von / *from* 2015-12-15
bis / *until* 2020-12-14

EN ISO 13849-1
EN 61508
PL 'd'
SIL 2

Zertifizierungsinhaber
TÜV NORD CERT GmbH

Essen, 2015-12-15

TÜV NORD CERT GmbH Langemarkstraße 20 45141 Essen www.tuev-nord-cert.de technology@tuev-nord.de

Bitte beachten Sie auch die umseitigen Hinweise
Please also pay attention to the information stated overleaf



EG - Baumusterprüfbescheinigung EC type-examination certificate

Hiermit wird bescheinigt, dass das unten beschriebene Produkt der Firma
This certifies that the product mentioned below from company

Johannes Hübner
Fabrik elektrischer Maschinen GmbH
Siemensstraße 7
35394 Gießen
Deutschland

die Anforderung des Anhangs 1 der Maschinenrichtlinie 2006/42/EG als eine Grundlage für die EG-Konformitätserklärung erfüllt.
meets the requirements of Annex 1 of the Directive 2006/42/EC as a basis for the EC declaration of conformity.

Gepprüft nach: **EN ISO 13849-1:2008 (PL d)**
Tested in accordance with: **EN 61508:2001 (SIL 2)**

Beschreibung des Produktes: **Grenzdrehzahlschalter**
(Details s. Anlage 1) **Overspeed switch**
Description of product:
(Details see Annex 1)

Typenbezeichnung: **EGS(H)41**
Type designation:

Bemerkungen: **Bitte beachten Sie auch die Hinweise im Anhang**
Remarks: **Please also pay attention to the Annex**

Registrier-Nr. / *Registration No.* 44 205 14153103
Prüfbericht Nr. / *Test Report No.* 3515 2599
Aktenzeichen / *File reference* 8000423260

Gültigkeit / *Validity*
von / *from* 2015-07-30
bis / *until* 2020-07-29

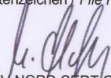
TÜV NORD CERT GmbH
Zertifizierungsstelle Maschinen
Certification Body Machinery
Benannte Stelle 0044 / *Notified Body 0044*

Essen, 2015-07-30

TÜV NORD CERT GmbH Langemarkstraße 20 45141 Essen www.tuev-nord-cert.de technology@tuev-nord.de

Bitte beachten Sie auch die umseitigen Hinweise
Please also pay attention to the information stated overleaf



ANLAGE ANNEX

Anlage 1, Seite 1 von 2
Annex 1, page 1 of 2

zur EG-Baumusterprüfbescheinigung / to EC type-examination certificate
Registrier-Nr. / Registration No. 44 205 14153103

Allgemeine Angaben: General information:	Siehe Seite 1 der EG-Baumusterprüfbescheinigung See page 1 of the EC type-examination certificate
Versorgungsspannung: Supply voltage:	12 bis 30 VDC/ 100 bis 240 VAC 12 to 30 VDC / 100 to 240 VAC
Schalterspannung: Switching voltage:	Max. 30 VDC/ 30 bis 230 VAC/DC Max. 30 VDC / 30 to 230 VAC/DC
Verwendungszweck: Intended application:	Elektronischer Grenzdrehzahlschalter zur Drehzahlüberwachung von elektrischen und mechanischen Antrieben mit sicherheitsgerichteten Schaltsignal Electronic overspeed switch for speed monitoring of electrical and mechanical drives with safety-related switching signal
Besondere Hinweise: Special requirements:	Es sind die besonderen Hinweise / Auflagen im Abschnitt 8 des Berichtes 12 207 408292 zu beachten The particular requirements listed in section 8 of the test report No.12 207 408292 must be taken into account

TÜV NORD CERT GmbH
Zertifizierungsstelle Maschinen
Certification Body Machinery
Benannte Stelle 0044 / Notified Body 0044

Essen, 2015-07-30

TÜV NORD CERT GmbH Langemarckstraße 20 45141 Essen www.tuev-nord-cert.de technology@tuev-nord.de



ANLAGE ANNEX

Anlage 1, Seite 2 von 2
Annex 1, page 2 of 2

zur EG-Baumusterprüfbescheinigung / to EC type-examination certificate
Registrier-Nr. / Registration No. 44 205 14153103

Besondere Hinweise:
Special requirements:

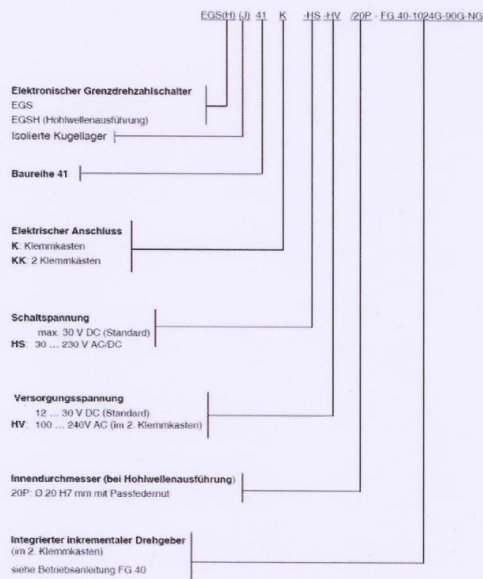

TÜV NORD CERT GmbH
Zertifizierungsstelle Maschinen
Certification Body Machinery
Benannte Stelle 0044 / Notified Body 0044

Essen, 2015-07-30

TÜV NORD CERT GmbH Langemarkstraße 20 45141 Essen www.tuev-nord-cert.de technology@tuev-nord.de