

The I210 is a weight indicator with a high velocity and precision of conversion A/D with housing in Stainless Steel IP68. CE-M approvable (OIML R-76 / EN 45501).

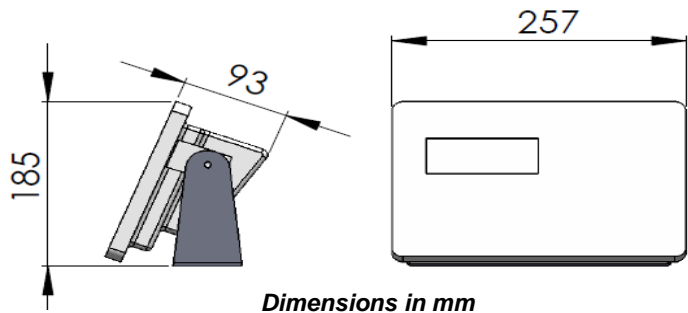

## CHARACTERISTICS

- With IP68 waterproof.
- Up to 1/15,000 display resolution (Internal resolution 1/300,000).
- LCD display (6 digits, 25mm) with LED backlight.
- Analog Input and A/D Conversion: Input Sensitivity  $0.3 = V/d$  (Min.).
- Load Cell Drive Capacity: up to 4 load cells at 350 @ /load cell.
- Input Signal Range:  $-1mV \sim +14mV$ .
- Input Zero Range:  $-1mV \sim +5mV$ .
- Load Cell Excitation: 5V DC  $\pm 5\%$  100Ma.
- Non-linearity: 0.01% of full scale.
- A/D Resolution: 500,000 counts (Max.).
- 1/15,000 display resolution (1/3,000 & 1/6,000 display resolution available).
- Operating Temperature:  $0^{\circ}C \sim 40^{\circ}C$  ( $32^{\circ}F \sim 104^{\circ}F$ ).
- Power Source: Adaptor DC 9V or 6V / 4.5Ah rechargeable battery.

## FUNCTIONS

- Kilogram (kg) and pound (lb) weighing modes
- Adjustable weighing speed: three weighing speed modes (fast, moderate, and slow).
- Digital calibration, Full range tare, Auto zero tracking, Simple counting, Gross/Net Indication.
- Hold function, Check mode Lo / Hi / OK, Auto average unit weight.
- Adjustable gravity value
- Low power indication and auto power off.
- Ticket Print : Data/Hour / Net/ Gross/Tare with number weights and totalization

## I/O SECTION

- RS232 output for PC or repeater connection.

