

Multifunction digital weight indicator in Rack version complete with 4 connectors for linking the platforms, built-in rechargeable battery, battery charger, thermal printer, time/date and case. It is particularly suitable for vehicle weighing applications. CE-M approvable (OIML R-76 / EN 45501).

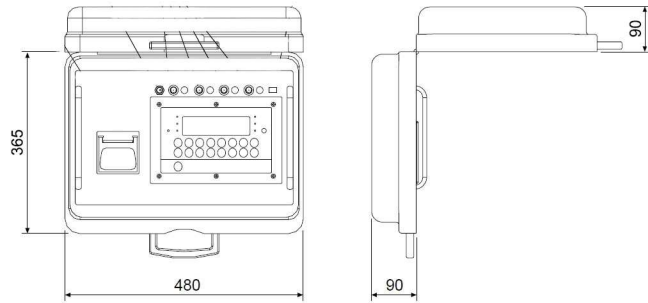

Dimensions in mm

CHARACTERISTICS

- Waterproof functional keyboard with 17 keys.
- LCD backlit display with 6 25-mm high contrast digits and with indication of active functions.
- Rack type metallic case.
- Calibration, set-up parameters, printouts, etc., all configurable from keyboard.
- Instrument management & configuration from PC with DINITOOLS.
- Up to 10.000e in singol range mode @ 0,3 $\mu\text{V/d}$ in CE-M approved version for legal for trade use.
- Up to 800,000 displayable divisions with internal resolution up to 3.000.000 points.
- A/D 24-bit 4-channel sigma-delta conversion, up to 200 conv./sec. autoselect and up to 8 signal linearization points.
- Fitted with 4 connectors for connection to 4 platforms (up to 8 optional).
- Connectable with up to 8 analogue load cells having 350 Ohm input resistance.
- Built-in rechargeable battery (10-hour minimum operating time, recharge in 8 hours) with fitted external 12 Vdc / 230 Vac adapter.
- **Fitted with thermal printer, time/date**, case for housing indicator and with space for other accessories.
- Dimensions: 325x460x170 mm; Total weight: about 5 kg.

FUNCTIONS

- Zero cycle on all the connected platforms.
- Visualisation of the weight of each single platform, of the total weight or of any combination of the platforms.
- Visualisation of the weight of each axle (rms) and of the total weight.
- Simple vehicle weighing with printing of the weights of each single wheel and of the total weight.
- Totalisation of Tractor + Trailer, with printing of the subtotals and of the vehicle total.
- Static axle totalisation, with printing of the weight of each single axle and of the vehicle total.
- Simple input/output.
- Input/Output with axle totalisation.
- Grand total of the weighed vehicles.
- Calculation and printing of the barycentre.

I/O SECTION

- **Available on the panel:**
 - 1 RS232/C (or optionally RS485 or USB) bi-directional 9-pin port for PC.
 - 1 IR input for remote control.
- **Available in the indicator:**
 - 1 RS232/C port configurable for connection with printer.

OPTIONS

- OMMC:** Memory data printer for mounting on weight indicator in rack version, with connection cable, memory card, power supply from weight indicator.
- RFITR:** Integrated 868 MHz radio frequency module on the indicator, complete of RS232 port. Max. functioning distance in appropriate environmental and installation conditions: 70m indoors, 150m outdoors. Up to 50 configurable channels.
- OBRFUSB:** 868 MHz radio frequency module for PC, with PVC box and 1 m USB/mini USB connecting cable; power supply directly from the USB port. Max. functioning distance, in appropriate environmental and installation conditions: 70m indoors, 150m outdoors. 50 configurable channels. (OBRFUSB must be combined with another radio module).

