

2960-2962-2965

LOW-PROFILE (PANCAKE) LOAD CELLS

Universal tension and compression load cells for industrial force measurement.



Model 2960 - 300 kN



Features

- o Flat design
- o High stiffness and fatigue resistant
- o Highly resistant to transverse forces
- o Protection class: IP66
- o Complete range of mounting accessories available
- o Material: stainless steel (2960)**, anodised aluminium alloy (2962), alloy steel (2965)
- o Cable length: see drawing table - CL (other lengths available on request)

Most popular options



Application(s)

SENSY's load cells 2960-2962-2965 are perfectly designed for the following applications:

- Force measurement on machines, industrial process control, hydraulic cylinders monitoring, fatigue tests,
- Hydraulic cylinders monitoring.

Capacities

2962: (3) - 5 - 7.5 kN

2960 - 2965: 10 - (15) - 20 - (30) - 50 - (75) - 100 - 150 - 200 - 300 - 500 - (750) - 1.000 - (1500) - 2.000 - 3.000 kN

Specifications	0.25 %	0.1 %	0.03 %	
Accuracy class	0.25 % F.S.*	0.1 % F.S.*	0.03 % F.S.*	-
Combined error (non-linearity + hysteresis)	<± 0.25	< ± 0.1	<± 0.03	% F.S.*
Repeatability error	<± 0.1	<± 0.03	<± 0.015	% F.S.*
Creep error over 30 min.	<± 0.1	<± 0.06	<± 0.025	% F.S.*
Reference temperature	23	23	23	°C
Compensated temperature range	-10...+45	-10...+45	-10...+45	°C
Service temperature range	-25...+70	-25...+70	-25...+70	°C
Storage temperature range	-50...+85	-50...+85	-50...+85	°C
Temperature coefficient of the sensitivity	<± 0.05	<± 0.05	<± 0.015	% F.S./10°C
Temperature coefficient of zero signal	<± 0.035	<± 0.035	<± 0.023	% F.S./10°C
Nominal sensitivity	2	2	2	mVV
Sensitivity tolerance	<± 0.3	<± 0.3	<± 0.2	%
Input resistance	700 ± 2	700 ± 2	700 ± 2	ohm(s)
Output resistance	700 ± 2	700 ± 2	700 ± 2	ohm(s)
Insulation resistance (50 V)	> 5000	> 5000	> 5000	Mohm(s)
Reference excitation voltage	10	10	10	VDC
Permissible nominal range of excitation voltage	3...12	3...12	3...12	VDC
Safe load limit	150	150	150	% F.S.*
Breaking load	>300	>300	>300	% F.S.*
Permissible dynamic loading	70	70	70	% F.S.*
Static lateral force limit	50	50	50	% F.S.*

* F.S. : Full Scale.

** CSA and IECEx options are available only for stainless steel (2960) version.

Note: 0.03% only for anodised aluminium alloy (2962) version.

Specifications subject to change without notice.



ISO 9001 certified

2960-2962-2965 > STANDARD DIMENSIONS

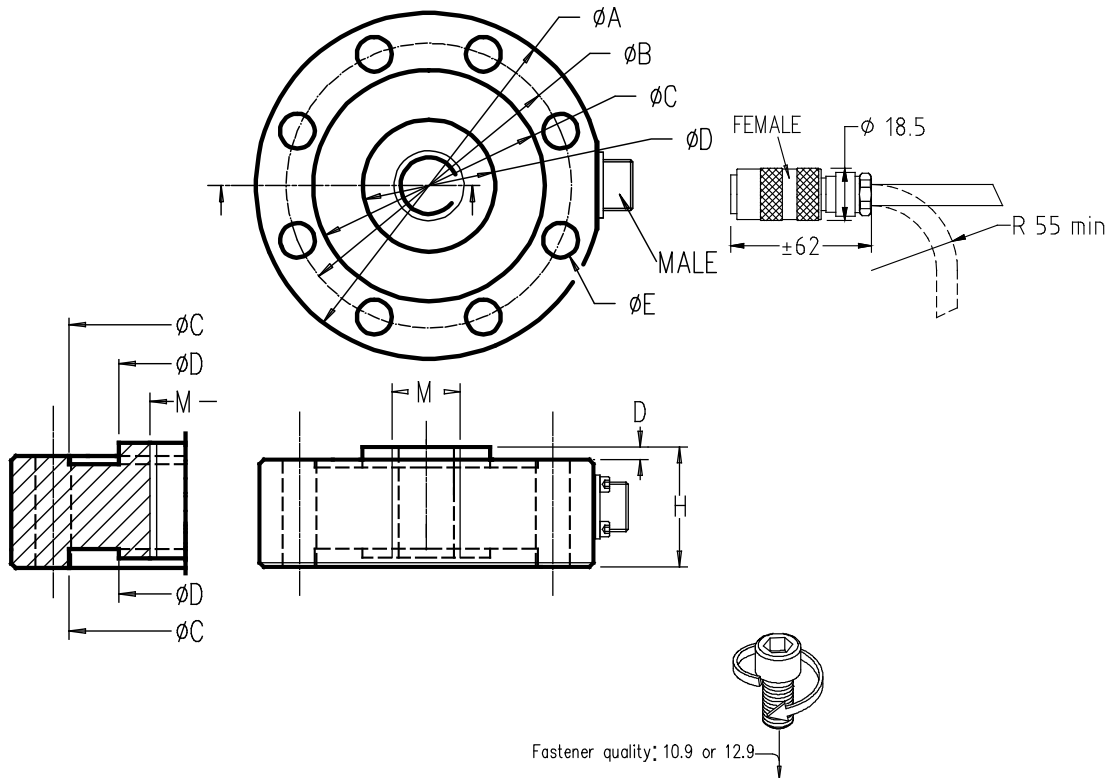

Ref. Item*	Capacities	ø A	ø B	ø C	ø D	ø E	M	H	D	CL (m)	H1	Max. Deflexion (mm)	Torque (N·m)	Weight (kg)	ACCESSORIES		
															APPUI	SUPOR	EMBOM
2962-A	3 - 7.5 kN	89	72	59	33	8xø8.2	M16	28	2	3	40	0.05	15 (M8)	0.3	APPUI-16B	SUPOR-36	EMBOM-M16-BA
296x-B	10 - 50 kN	89	72	59	33	8xø8.2	M20x1.5	28	2	3	40	0.04	40 (M8)	0.9	APPUI-20	SUPOR-36	EMBOM-M20x1.5-BA
296x-C	75 - 100 kN	149	125	106	46	8xø12.5	M30x2	38.5	2	6	53.5	0.05	130 (M12)	3.5	APPUI-30	SUPOR-45	EMBOM-M30x2-BA
296x-D	150 - 200 kN	178	145	115	69	8xø16.5	M36x3	50	2	6	70	0.06	320 (M16)	7	APPUI-36	SUPOR-69	EMBOM-M36x3-BA**
296x-E	300 - 500 kN	198	172	140	90	16xø16.5	M60x4	65	3	12	92	0.07	320 (M16)	12	APPUI-60	SUPOR-90	EMBOM-M60x4-PTFE**
296x-F	0.75 - 1 MN	279	229	180	120	16xø24.5	M90x4	70	3	12	103	0.08	1000 (M24)	28	APPUI-90	SUPOR-125A	EMBOM-M64x4-PTFE**
296x-G	1.5 - 2 MN	345	290	240	156	16xø32	M110x4	115	15	12	/	0.10	1300 (M30)	50	According to customer's design specifications		/
296x-H	3 MN	390	335	280	195	24xø24.5	M125x4	130	7	12	/	0.15	1000 (M24)	86	According to customer's design specifications		/

*x=Material: 2960 - stainless steel; 2965 - alloy steel

**See EMBOM data sheet (ACCESSORIES section)

Other capacities and dimensions available on request

Dimensions in mm

Accessories

Bases are mainly recommended if mating surface is of poor quality (for direct mounting, surface should be

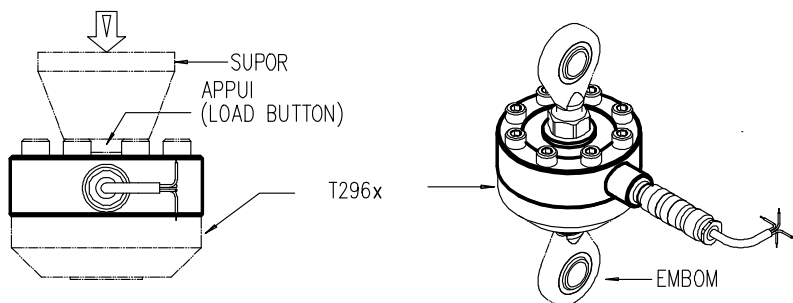
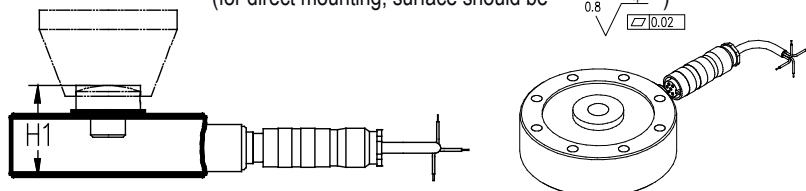

Wiring

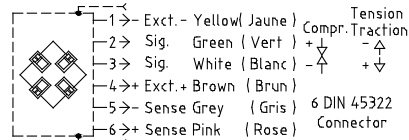

Standard : Cable screen not connected to transducer / Farodisation non connectée au capteur

Load direction

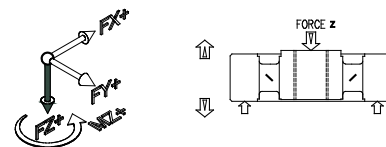

T2960-T2962-T2965 > STANDARD DIMENSIONS

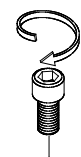
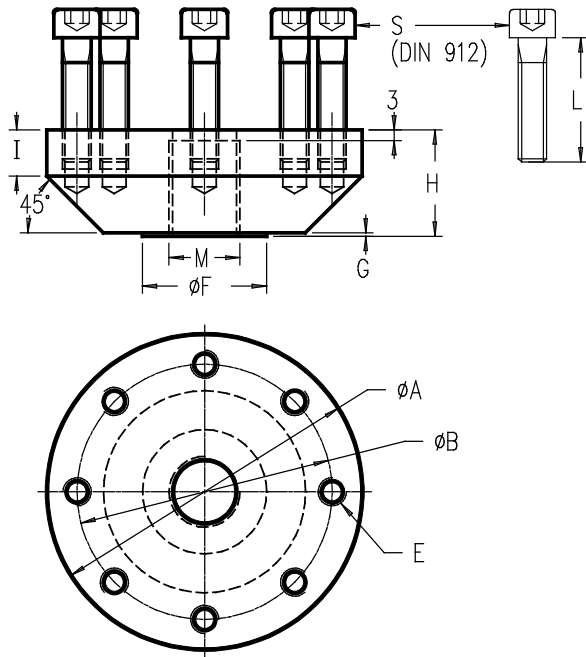

Ref. Item**	Capacities	Ø A	Ø B	E	Ø F	G	I	S	M	H	H1	H2	H3	H4	Torque (N·m)	Weight (kg)
T2962-A	3 - 7.5 kN	89	72	8xM8	25	1	13	8xM8 L=35	M16	30	70	105	58	143	15 (M8)	0.57
T296x-B	10 - 50 kN	89	72	8xM8	35	1	13	8xM8 L=35	M20x1.5	30	70	109	58	160	40 (M8)	1.19
T296x-C	75 - 100 kN	149	125	8xM12	52	1	20	8xM12 L=50	M30x2	46	99.5	140.5	84.5	225	130 (M12)	5.25
T296x-D	150 - 200 kN	178	145	8xM16	70	1	23	8xM16 L=70	M36x3	50	120	160	100	285	320 (M16)	8.7
T296x-E	300 - 500 kN	198	172	16xM16	115	1	35	16xM16 L=80	M60x4	65	157	219	130	455	320 (M16)	14.5
T296x-F	0.75 - 1 MN	279	229	16xM24	162	1	36	16xM24 L=100	M64x4	75	172	247	145	550	1000 (M24)*	35.5
T296x-G	1.5 - 2 MN	According to customer's design specifications														
T296x-H	3 MN	According to customer's design specifications														

*Fastener quality 10.9 or 12.9
 ** x=Material: T2960 - stainless steel; T2965 - alloy steel

→ Other capacities and dimensions available on request

Dimensions in mm

Other views

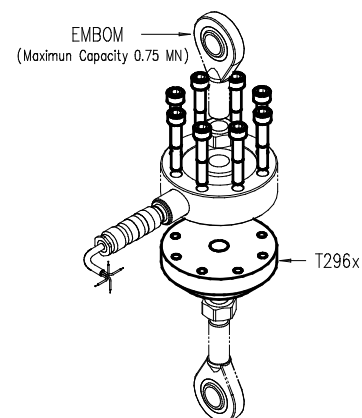
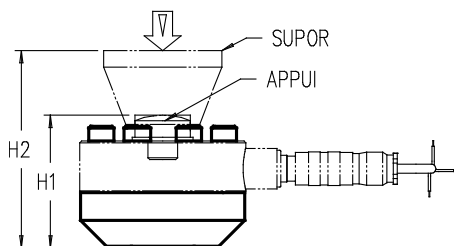
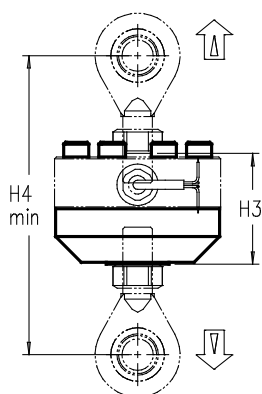

APPUI > STANDARD DIMENSIONS

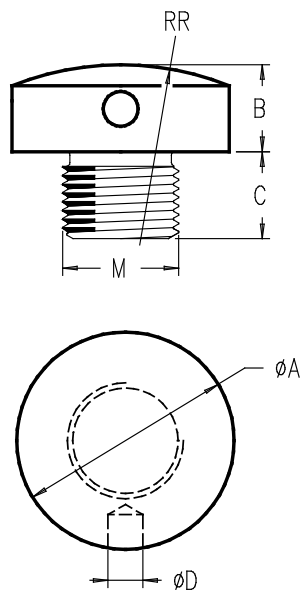

Ref. Item*	M	ØA	B	C	ØD	RR	Weight (kg)
APPUI-6	M 6	12	7	8	3 (1x)	16	0.02
APPUI-8	M 8	20	7	8	3 (1x)	25	0.02
APPUI-10	M 10	20	7	10	3 (1x)	25	0.02
APPUI-12	M 12	20	10	10	3 (1x)	35	0.03
APPUI-16	M 16	30	12	12	4 (1x)	50	0.08
APPUI-16B	M 16	36	12	12	5 (1x)	100	0.11
APPUI-20x1.5	M 20 x 1.5	36	12	15	5 (1x)	70	0.12
APPUI-24x2	M 24 x 2	36	12	18	5 (1x)	60	0.15
APPUI-30x2	M 30 x 2	45	15	20	6 (2x)	100	0.28
APPUI-36x3	M 36 x 3	56	20	24	6 (2x)	150	0.55
APPUI-36Bx3	M 36 x 3	69	20	35	6 (2x)	250	0.84
APPUI-45x3	M 45 x 3	64	20	30	6 (2x)	200	0.84
APPUI-56x4	M 56 x 4	90	24	35	8 (2x)	300	1.8
APPUI-60x4	M 60 x 4	90	27	40	10 (2x)	350	2.14
APPUI-90x4	M 90 x 4	125	33	50	12 (2x)	450	5.46

* Material: stainless steel

Dimensions in mm

Other views

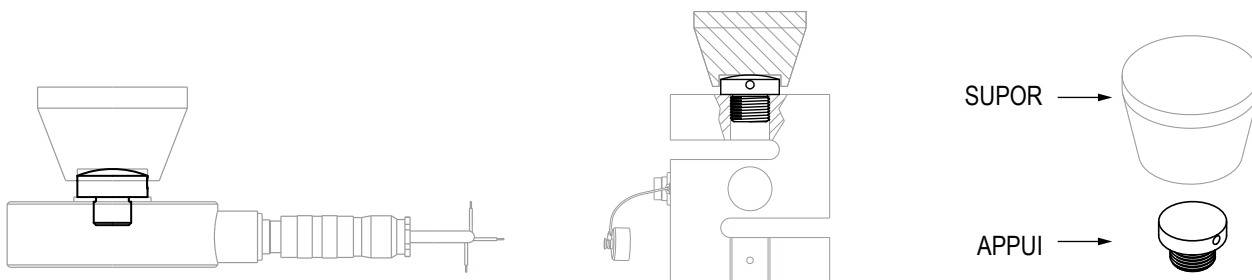

EMBOM > STANDARD DIMENSIONS

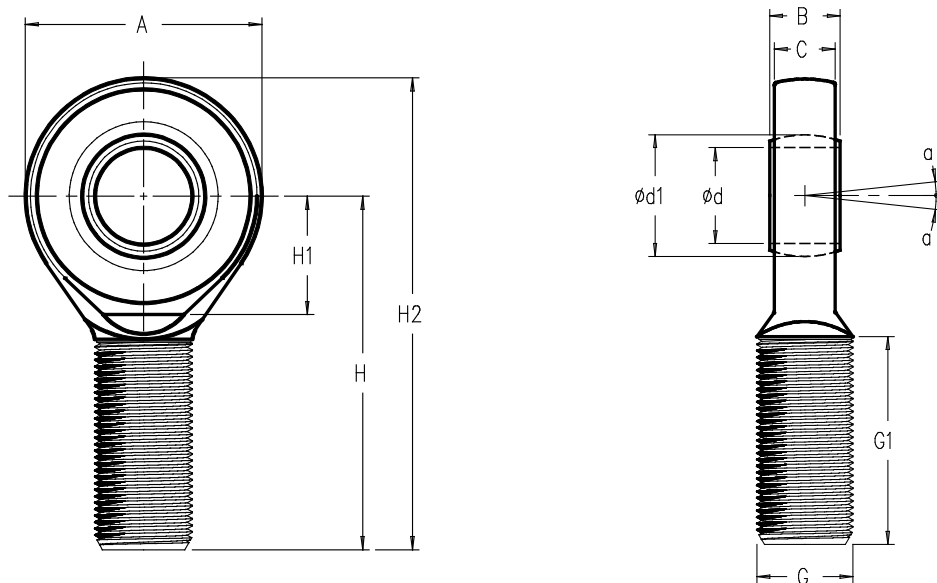

Ref. Item*	Dimension G	Capacities (N)		Ød	A	B	C	H	a (degree)	Ød1	G1	H1	H2	Weight (kg)
		Dynamic	Static											
EMBOM-M6-BA	M6	3600	9000	6	21	6	4.3	36	13	10	16	14	46.5	0.013
EMBOM-M8-BA	M8	5850	14600	8	24	8	6	42	15	13	21	14	54	0.025
EMBOM-M10-BA	M10	8560	21600	10	29	9	7	48	12	16	26	17	62.5	0.043
EMBOM-M12-BA	M12	11400	28500	12	34	10	8	54	10	18	28	18	71	0.065
EMBOM-M16-BA	M16	22400	52000	17	46	14	11	69	10	25	36	23	92	0.17
EMBOM-M20x1.5-BA	M20x1.5	31500	70000	20	53	16	13	78	9	29	43	25	104.5	0.28
EMBOM-M24x2-BA	M24x2	51000	102000	25	64	20	17	94	7	35.5	53	32	126	0.5
EMBOM-M30x2-BA	M30x2	65500	134000	30	73	22	19	110	6	40.7	65	33	146.5	0.83
EMBOM-M36x3-PTFE	M36x3	112000	143000	35	82	25	21	140	6	47	82	42	181	1.4
EMBOM-M45x3-PTFE	M45x3	220000	280000	50	112	35	30	185	6	66	104	60	241	3.55
EMBOM-M56x4-PTFE	M56x4	440000	630000	70	160	49	42	235	6	92	125	87	315	7.9
EMBOM-M60x4-PTFE	M60x4	345000	440000	60	135	44	38	225	6	80	120	70	292.5	6.25
EMBOM-M64x4-PTFE	M64x4	570000	780000	80	180	55	47	270	6	105	140	100	360	12

* Material: BA - bronze-auto lubricated ; PTFE - polytetrafluoroethylene

→ Other capacities and dimensions available on request

Dimensions in mm

Other view

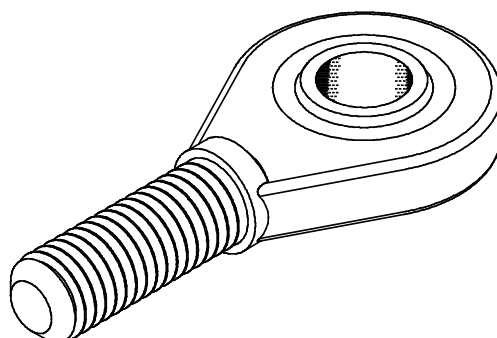

SUPOR > STANDARD DIMENSIONS

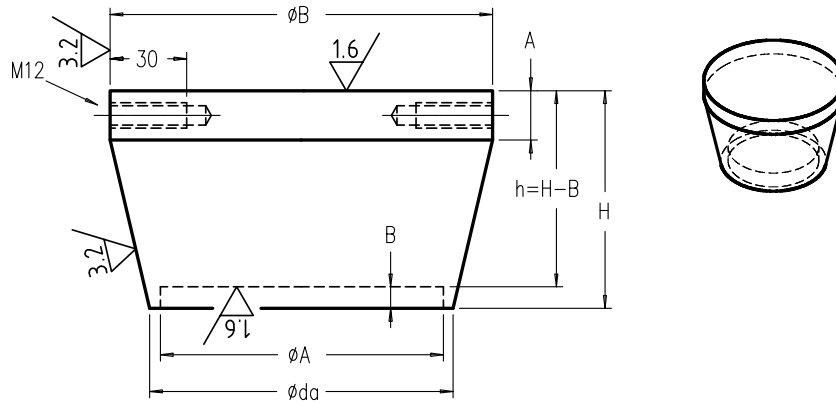

Ref. Item	Types	ØA	ØB	Øda	A	B	H	h	M12 L=30 (degree)	Weight (kg)
SUPOR-12	12	12	34	20	7	4	23	19	NO	0.12
SUPOR-20	20	20	49	30	8	5	31	26	NO	0.33
SUPOR-30	30	30	64	40	9	6	41	35	NO	0.74
SUPOR-36	36	36	69	46	10	7	46	39	NO	0.98
SUPOR-45	45	45	79	56	11	12	53	41	NO	1.5
SUPOR-56	56	56	79	66	12	8	48	40	NO	1.5
SUPOR-64	64	64	99	75	12	17	64	47	NO	2.8
SUPOR-64E	64E	64	114	75	12	17	75	58	NO	4.14
SUPOR-69	69	69	79	75	12	12	52	40	NO	1.6
SUPOR-90	90	90	129	100	15	17	79	62	NO	6
SUPOR-90B	90B	90	164	100	15	17	109	92	NO	12.2
SUPOR-110	110	110	195	135	20	19	109	90	2x to 180	18.7
SUPOR-125A	125A	125	158	135	20	19	94	75	2x to 180	11.3
SUPOR-125B	125B	125	195	135	20	19	109	90	2x to 180	18.3
SUPOR-160	160	160	248	±170	30	20	146	126	2x to 180	40
SUPOR-200A	200A	200	308	±210	30	20	175	155	2x to 180	73
SUPOR-200B	200B	200	353	±210	30	20	200	180	4x to 90	103
SUPOR-230	230	230	353	±270	50	35	211.5	176.5	4x to 90	125
SUPOR-250A	250A	250	438	±290	40	30	250	220	6x to 60	209
SUPOR-250B	250B	250	503	±290	40	30	285	255	6x to 60	294
SUPOR-300A	300A	330	594	±340	50	40	337	297	6x to 60	481
SUPOR-330A	330A	330	503	±370	50	50	301.5	251.5	6x to 60	341
SUPOR-360A	360A	360	694	±401	100	50	397	347	6x M24 / 360	818
SUPOR-400A	400A	400	594	±440	50	55	352	297	6x to 60	555
SUPOR-430A	430A	430	795	±470	±100	50	448	398	6x M30 / 360	1209

→ Other capacities and dimensions available on request

Dimensions in mm

Other views

