

# CSGI-IP68

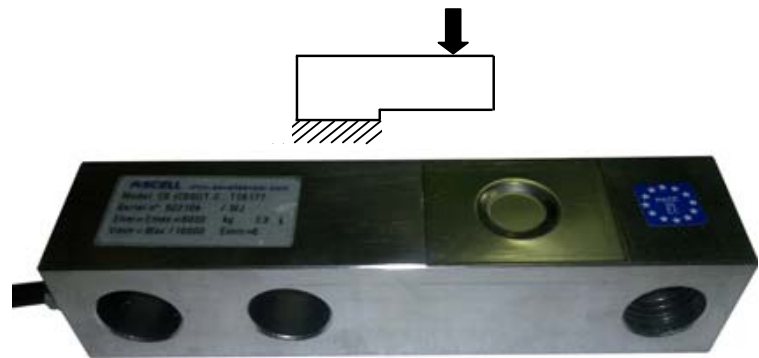

TEFLÓN® protects all the internal cables

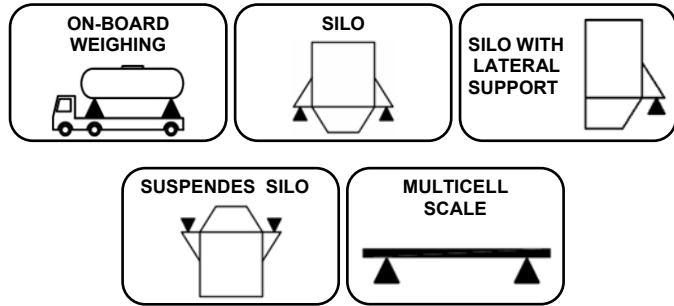
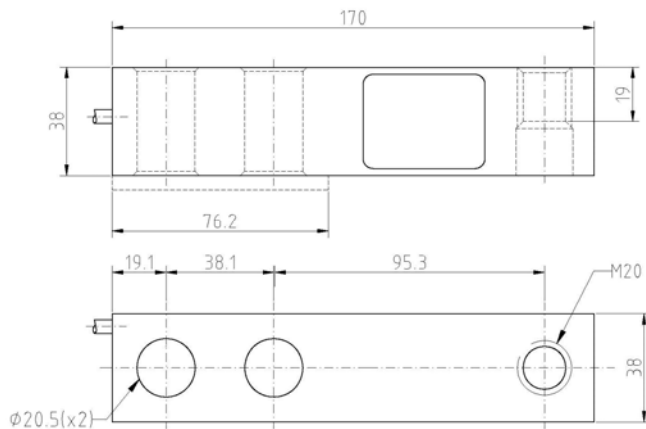

Dimensions in mm

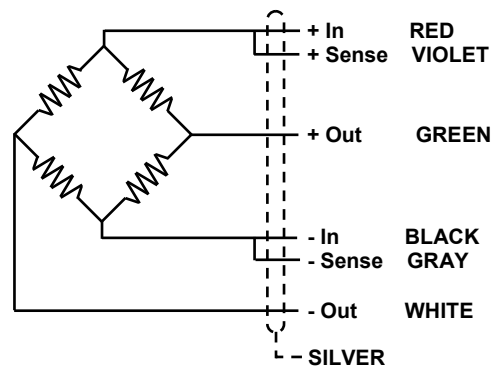

## APPLICATION:

Multi-cell scales

## CAPACITY RANGE:

3t - 5t

## MATERIAL:

Stainless steel

## ENVIRONMENTAL PROTECTION:

IP68

## APPROVALS:

CE 3000 Div - TC6177 for 3t

OIML 3000 Div - R60/2000-NL 1-03.02

## CHARACTERISTICS

Construction using stainless steel  
The laser soldered closing protects from the typical environment in food and chemical industry.  
Mounting compatibility.

## APPLICATIONS

The CSGI-IP68 model is manufactured to maintain its performance capabilities in the environmental conditions existing in industries, where tasks and cleaning demand a good environmental protection.

## OPTIONS

Length of the cable is optional.

Hostile environmental cable.

ATEX option

EC-Type examination certificate

CEC 11 ATEX 040 X according directive 94/9/EC

**Ex** II 1G EExia IIC T6 (Ta-20÷+40°C)  
TX (Ta-20÷+65°C)

**Ex** II 1D tD A20 TX°C (Ta-20÷+40°C)  
TX°C (Ta-20÷+65°C)

For more information look up the EC-type examination certificate, and documentation.

Consult for special requirements.

www.ascellsensor.com  
info@ascellsensor.com

Tel: (+34) 93 776 60 89  
Fax: (+34) 93 775 14 72

## GENERAL TECHNICAL CHARACTERISTICS FOR $g= 9,8031 \text{ m/ s}^2$

OIML Class	C3	UNITS
Divisions $n_{LC}$	3000	
Minimum Dead load $E_{min}$	0	kg
$Z= E_{max} / 2DR$	3000	
$Y= E \text{ max.} / V_{min.}$	10000	
Rated Capacity $E_{max}$	3000 - 5000	kg
Rated Sensitivity C	$2 \pm 0,1 \%$	mV/V
Rated Input Voltage	10	V dc
Input Voltage Range	5...15	V ac/dc
Input Resistance $R_{LC}$	$350 \pm 3$	$\Omega$
Output Resistance	$350 \pm 3$	$\Omega$
Zero Balance	$\pm 2$	% Emax
Insulation Resistance at 50 V DC	> 5000	M $\Omega$
Service Overload	> 150	% Emax
Overload Limit	> 300	% Emax
Temperature Range : Compensated	- 10 ... 40	$^{\circ}\text{C}$
: Operating	- 30 ... 85	$^{\circ}\text{C}$
: Storage	- 30 ... 90	$^{\circ}\text{C}$
Max. Nonlinearity	0,02	% Emax
Max. Hysteresis	0,02	% Emax
Max. No repeatability	0,01	% Emax
M Max. Creep in 4 hours	0,03	% Emax
Max. Zero Recovery Test in 1/2 hour	0,011	% Emax
Max Temperature effect : On Sensitivity	0,0013	% Emax / $^{\circ}\text{C}$
: On Zero	0,0014	% Emax / $^{\circ}\text{C}$
Weight	1500	g
Cable Length	5	m
Environmental Protection	IP68 - DIN 40050 (100h 1m)	



Ref: 491210  
Ref: 491212 (S. Steel)



Ref: 491102



Ref: 491213



Ref: 491215  
Ref: 491218 (S. Steel)