

7010 Liquid Level Sensor

User Manual



TABLE OF CONTENTS

1. Product Description	3
2. Getting Started	5
3. Configuration	6
4. Installation	8
5. Specifications	15
6. Maintenance, Returns & Decommissioning	17
7. Appendix	18

1. PRODUCT DESCRIPTION

The 7010 Liquid Level Sensor is designed for use in harsh environments at extreme operating temperatures where the continuous real-time liquid level monitoring of a variety of fuels, oils, chemicals, saline, and water is required. The sensor has no moving parts, floats or mechanical linkages providing excellent long term reliability.

Liquid level detection is achieved through solid-state capacitive technology. An outer tube and inner rod act as the plates of a capacitor, with any liquid providing the dielectric between the two. As the liquid level rises and falls, the capacitance of the sensor changes linearly. The on-board electronics process this and provides an output as a voltage or current signal.

Calibration of the sensor is achieved by setting a maximum (full) and minimum (empty) level for the desired liquid. The liquid level between these points is determined by proportionally relating the output to the two set points, while taking account for the dielectric constant value of the liquid.

If requested, further accuracy can be gained by compensating for the effect of temperature changes on the output in a given liquid with offsets across the temperature range.

Your chosen calibration has passed through Gill Sensors & Controls Limited's quality control to ensure the sensor provides market leading measurement accuracy in your specified liquid.

The sensor is designed to operate in fluids where deposits or build-up of sediment are not expected, as this may block the bleed holes unless they are regularly maintained. For fluids where deposits or build-up of sediment are expected, please contact Gill Sensors & Controls Limited for a suitable sensor.



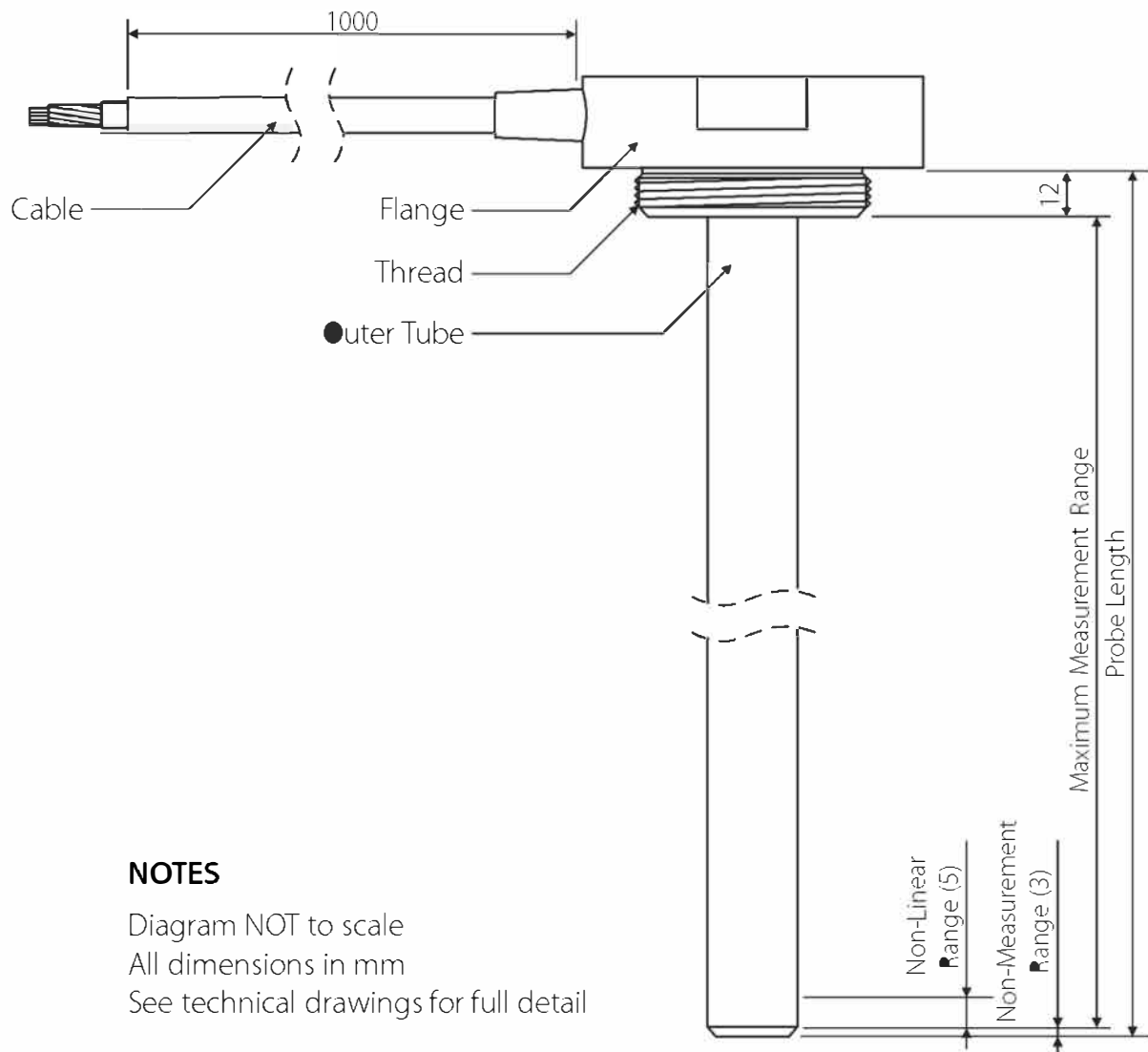

A breakdown of the sensor is provided below with key measurement considerations. This is provided as a guide only, please consult the full technical drawings for exact dimensions.



The sensor electronics are housed in the flange, outside the measurement tank. The outer tube is placed into the measurement tank, such that will be submerged in liquid. The sensor can be installed using either built in thread or a five bolt SAE mounting, both providing a tank seal.

2. GETTING STARTED

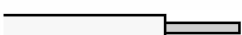
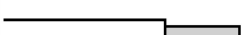
The analogue output cable has seven wires:

	Red	D.C. power supply
	Black	Ground
	Orange	Primary Output
	Yellow	Secondary Output
	White	TX
	Green	RX
	Silver	Drain wire

The installation of the sensor has different requirements, depending on the analogue output:

Voltage The sensor will provided with a factory calibrated output range of 0.25 V to 4.75 V. The sensor can be configured to a maximum output range of 0.25 V to 10 V.

The power supply must be at least 0.5V greater than the maximum output voltage required. The switch output requires a pull-up resistor of 1 kOhm to 10 kOhms.

Current The current output is 4 – 20 mA. The measurement output requires a 250 Ohm load resistor across the output. The switch output requires a pull-up resistor of 1 kOhm to 10 kOhms.

	Voltage	Current (4-20mA)
Supply Voltage	+5 to +32 VDC	+9 to +32 VDC
Over Voltage Protection	>32 VDC	>32 VDC
Supply Current @ 12 VDC	<15 mA	<15 mA
Reverse Polarity Protection	Yes	Yes
Analogue Resolution	10 bit	10 bit
Report Rate	10 Hz	10 Hz

3. CONFIGURATION

The sensor can be configured using GSlevel software, available from www.gillsc.com/support. Select the 7010 Liquid Level Sensor from the "Select Product" dropdown list.

The minimum operating system requirements are:

- 32-bit (x86) or 64-bit (x64) processor
- Windows® 7 or later
- 1 Gb RAM
- 500 Mb disk space
- One free USB port to connect a sensor

A connector is required to configure the sensor with a computer. Gill Sensors & Controls Limited provide an RS232 to USB adaptor (P/N 1484-00-086). Please contact us if you require this device.

The GSlevel User Manual is accessible through the software. Install and run the software, then click the 'Help' button in the bottom right of the window, shown in the screenshot below.

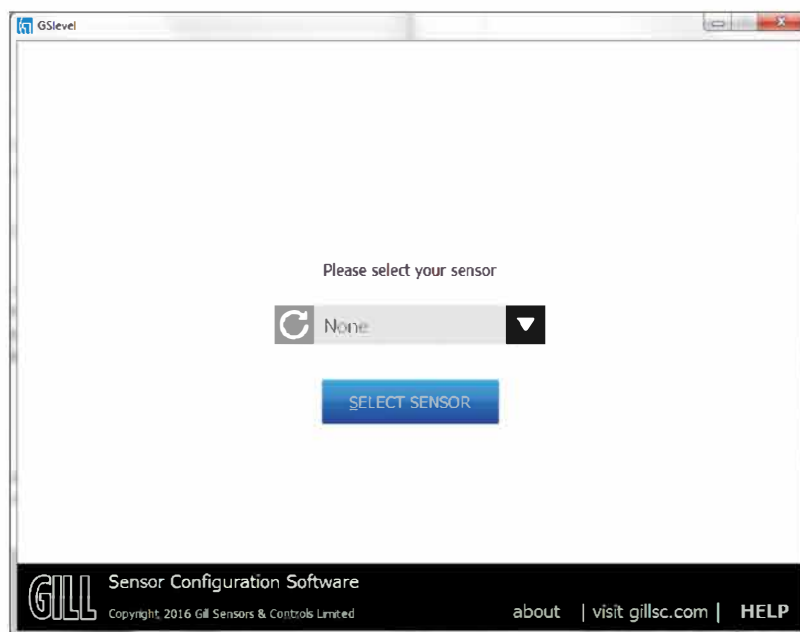

Click for GS level user manual

3.1 TANK PROFILING

The sensor is configured for use with regular tank profiles, such as that shown below.

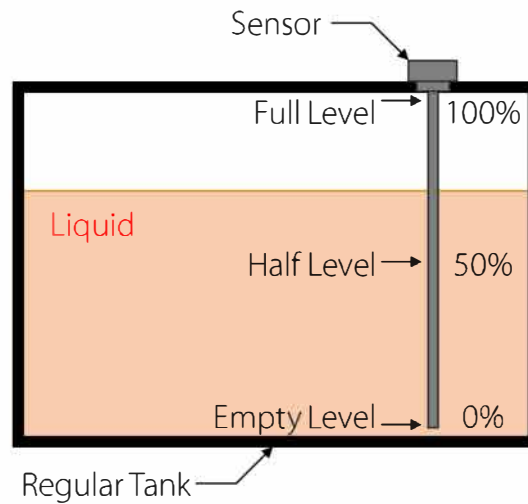

The sensor is supplied so that it reports the level in a linear path as the level rises. However, this will not be suitable for an irregular shaped tank, such as that shown below.

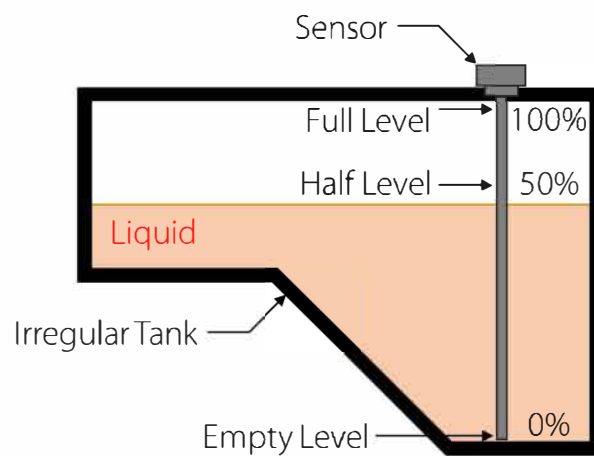

In this situation, 50% of tank volume is not half way up the probe. To correct for this tank profiling can be used. This can be done in the GSlevel software and is covered in detail in the GSlevel User Manual.

4. INSTALLATION

Do not remove the packaging until you are ready to install the sensor. Prior to installation, please check the sensor for any signs of transit damage. Contact Gill Sensors & Controls Limited immediately if this is the case.

IMPORTANT **DO NOT** attempt to cut the sensor to length or bend the sensor. Both actions will result in the sensor failing and will invalidate the warranty.

IMPORTANT The sensor must not be used in a tank that is not adequately vented.

IMPORTANT The sensor flange and cable must not be immersed in the liquid.

IMPORTANT Diagrams in this section are not to scale and are for reference only.

This manual covers installation of sensors in the conventional manner (see below). For inverted installation (see below) please contact Gill Sensors & Controls Limited.

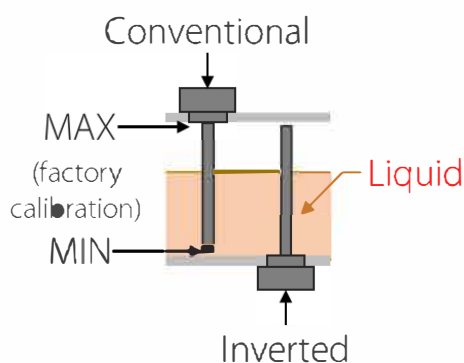

All 7010 sensors can be mounted using a SAE 5-bolt pattern and the supplied gasket. Depending on the unit ordered, the sensor can be installed using a 1.125" UNF or 1.25" BSP thread and the supplied O-ring.

The sensor must be installed on a flat surface, such that it occupies the deepest part of the tank to be measured.

The sensor can be installed at any angle from vertical to a maximum recommended angle of 45°. For sensors over 500 mm in length in dynamic applications, in-tank support of the probe is recommended. Ensure that the mounting hole in the tank is strong enough to withstand the forces imposed by the sensor from its weight and the vibrations it may be exposed to. Please contact Gill Sensor & Controls Limited to discuss specific sensor requirements when mounted at an angle.

Before installation, ensure you have sufficient clearance above the tank in to order to mount the sensor. The sensor is rigid, therefore the clearance height must be, at a minimum, the designated length of the sensor plus 30mm to allow for the flange. Sideways clearance may also be required, and should be accounted for.

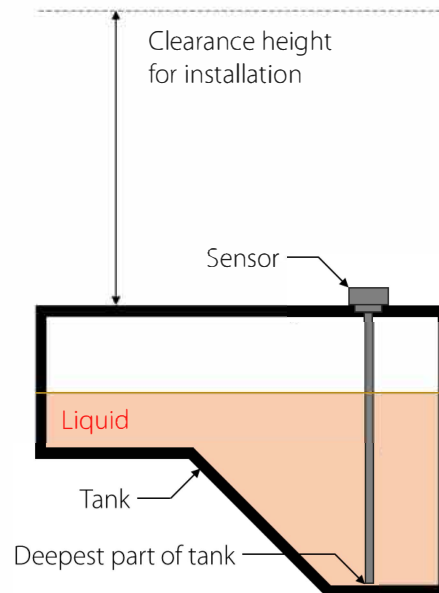

4.1 PARTS SUPPLIED

7010 Liquid Level Sensor
O-ring and Gasket
Quick Start Guide

4.2 CABLE LENGTH & STRAIN RELIEF

The sensor is provided with a flying lead of 1000mm, which may be shortened appropriate to the application. Ensure that the cable is secured to avoid damage during operation. It is recommended that cable length is kept to a minimum to prevent large voltage drops over the length of the cable which may affect the operation of the sensor.

Cable strain relief is provided at the sensor. Care should be taken not to stress the cable at the cable entry. The minimum recommended cable bend radius is 20mm. It is recommended that you do not connect the cable before installation.

4.3 1.125" UNF THREAD INSTALLATION

The sensor is supplied with both an O-ring and a Gasket. To use the supplied O-ring, the mounting hole requires a chamfer to be machined around the upper edge. If a chamfer cannot be created, then the supplied Gasket should be used. Ensure that sufficient space is allowed around the sensor flange for the cable to bend.

4.3.1 Using the O-ring

The recommended mounting hole and chamfer size for use with the O-ring are shown below.

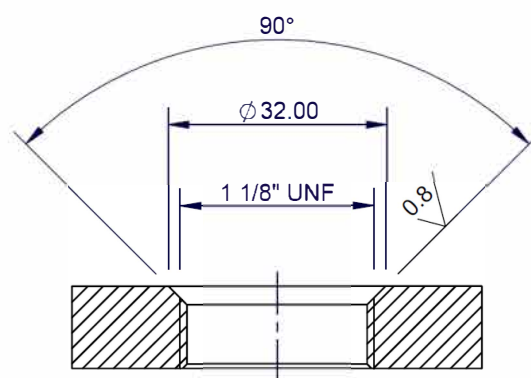

Fit the O-ring above the male thread on the sensor. Ensure the O-ring is centred and sits within the chamfer; tighten the sensor using a 59.5 mm A/F spanner until the sensor face is flush with the top of the tank and a torque of 50 Nm is achieved.

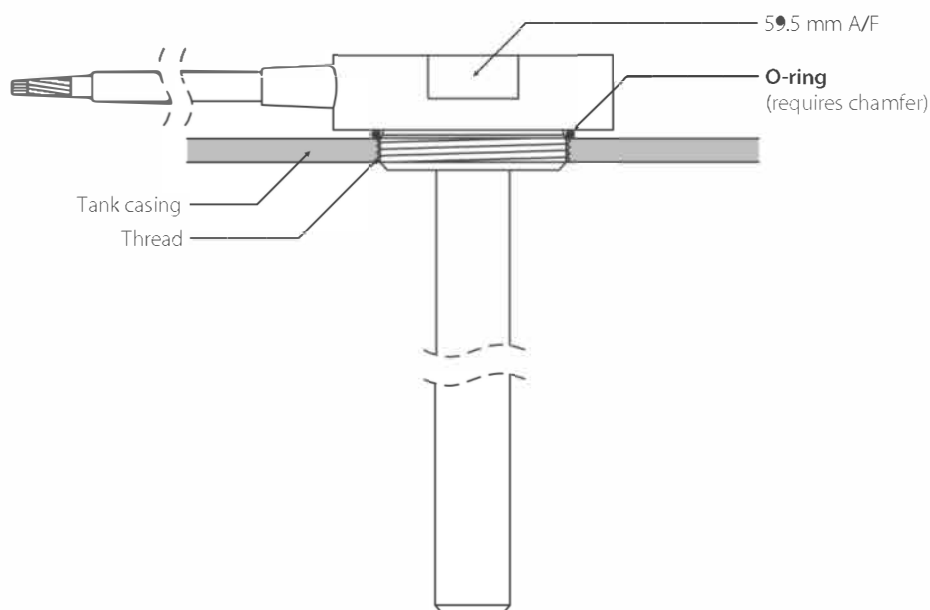

4.3.2 Using the gasket

The recommended mounting hole for the gasket is shown below.

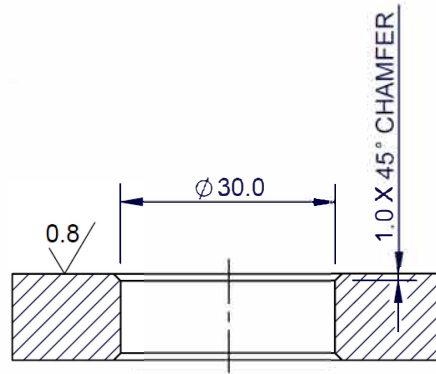

Fit the gasket over the thread mount, black face up. Ensure the gasket is centred under the sensor and tighten the sensor using a 59.5 mm A/F spanner to a torque of 50 Nm.

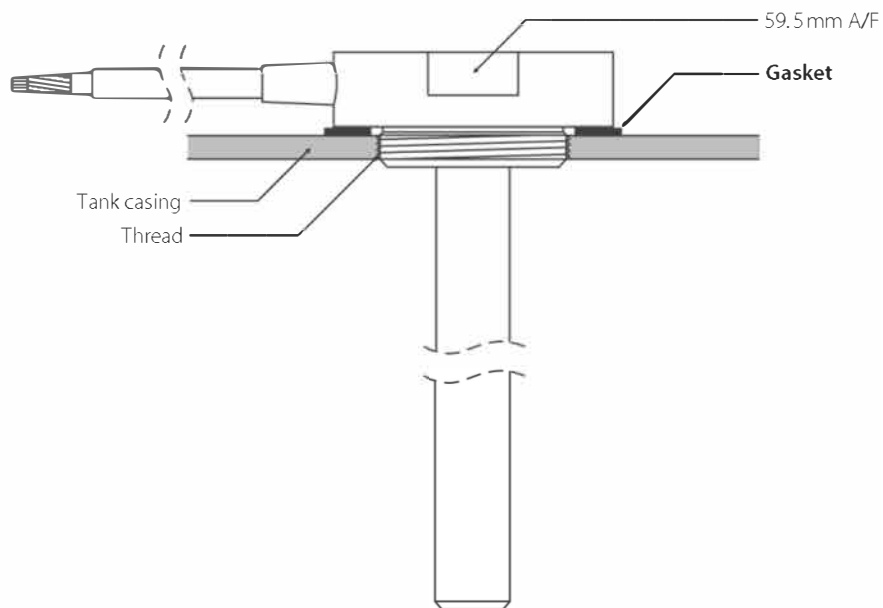

4.4 1.25" BSP THREAD INSTALLATION

The sensor is supplied with both an O-ring and a Gasket. To use the supplied O-ring, the mounting hole requires a chamfer to be machined around the upper edge. If a chamfer cannot be created, then the supplied Gasket should be used. Ensure that sufficient space is allowed around the sensor flange for the cable to bend.

4.4.1 Using the O-ring

The recommended mounting hole and chamfer size for the O-ring is shown below.

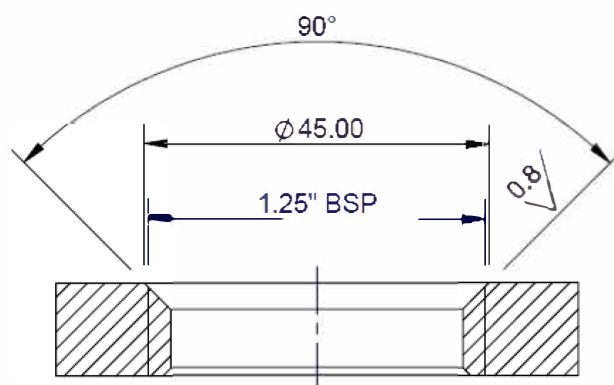

Fit the O-ring above the male thread on the sensor. Ensure the O-ring is centred and sits within the chamfer; tighten the sensor using a 59.5 mm A/F spanner until the sensor face is flush with the top of the tank and a torque of 50 Nm is achieved.

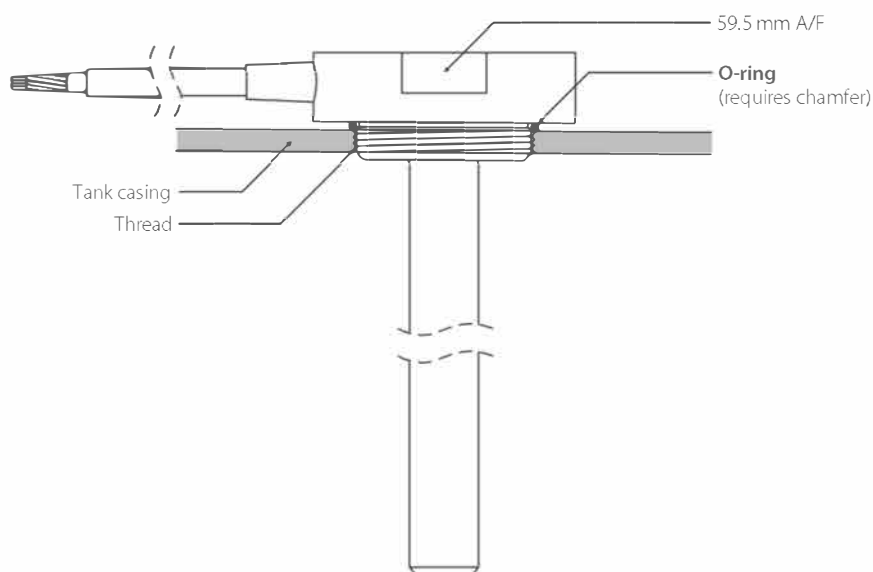

4.5 SAE 5-BOLT INSTALLATION

All 7010 sensors, of either thread type, come with a SAE 5-bolt installation option. This installation option requires 5 holes to be tapped into the tank. The pattern for these holes is outlined below.

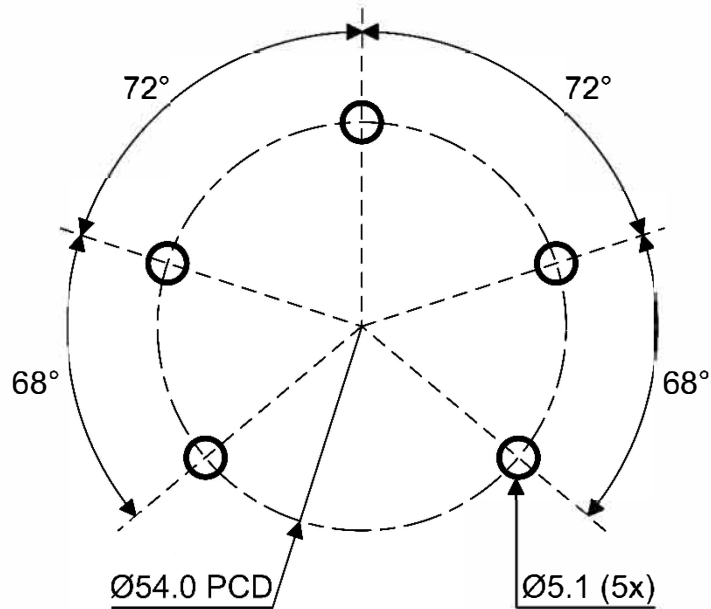

The sensor should be fitted with a gasket if the SAE 5-bolt installation method is used. Fit the gasket over the bolts, black face up, and tighten the bolts to a torque of 10 Nm each.

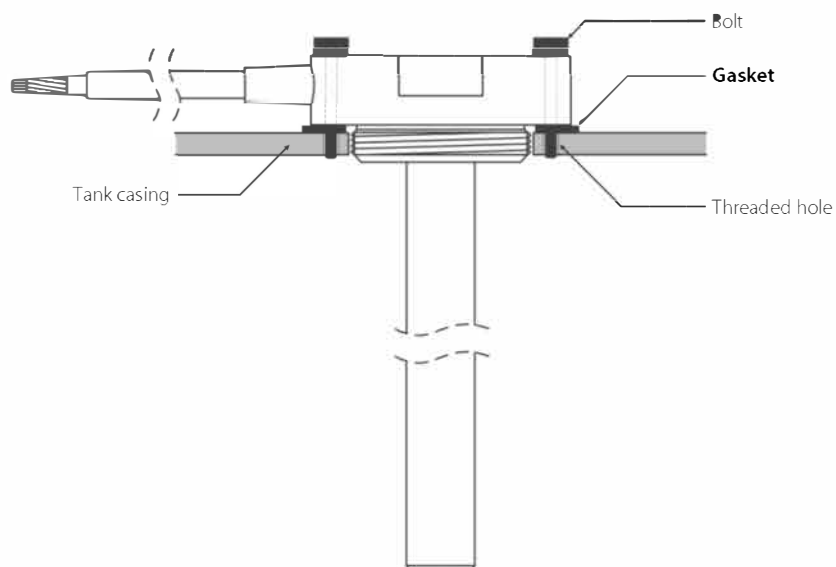

5. SPECIFICATIONS

5.1 GENERAL

Primary Output Accuracy:	±2% FSD @ 20°C
Operating Temperature:	-40 to 125°C
Humidity:	93% RH at 40°C
Pressure:	10 Bar (differential and absolute)
Compatible Media:	Fresh Water, Saltwater, Ethylene Glycol, Gasoline, Unleaded, LRP, Diesel Please consult Gill for other liquids
Seal Materials:	Fluorosilicone O-rings Klingersil Gasket
Ingress Protection:	IP66, IP68
EMC:	EN 61000, EN 61326, EN 60945

5.2 MECHANICAL

Construction Materials:	Stainless Steel 316, FEP, PEI
Probe Length:	100mm to 2000mm (in standard increments)
Mounting Options:	SAE 5-bolt; 1.125"UNF or 1.25" BSP threaded
Weight:	From 300g (dependent on length)

5.3 ELECTRICAL

	Voltage	4-20 mA
Supply Voltage:	+5 to +32 VDC	+9 to +32 VDC
Over Voltage Protection:		>32 VDC
Supply Current @ 12 VDC:		< 15 mA
Reverse Polarity Protection:		to -32 VDC
Analogue Resolution:		10 bit
Report Rate:		10 Hz
Sensor Configuration:		Accessible via USB

5.4 ANALOGUE OUTPUTS

Factory Calibrated Output:	0.25 V – 4.75 V
Maximum Output Range:	0.25 V – 10.0 V
Current Output:	4 – 20 mA
Switch Output:	Open collector output 50 V / 1A max Switch to ground

5.5 CONNECTION

Cable:	20 AWG TYPE 44, DR25 sleeving
Cable Tail Length:	1000mm

5.6 SHOCK & VIBRATION

BS EN 60068-2-6:2008 - Sinusoidal Vibration

Test 1 - Initial Resonance Search

With the units not-operating a resonance search from 10Hz to 500Hz at 0.5g peak, sweep rate not exceeding 1.0 octave/minute was carried out.

Test 2 - Sinusoidal Vibration

With the units non-operating the following vibration test was applied in each of the units three axis: 10Hz to 500Hz at 50m/s² peak, sweep rate 1 octave per minute, 10 sweep cycles in each of three axes.

BS EN 60068-2-6:2009 - Shock

Test Level;	25g
Pulse Duration;	6ms
Pulse Shape;	Half Sine
No. of Shocks;	1000 shocks in each direction of each axis
(6000 total)	

5.7 PART NUMBER CONFIGURATION

The configuration of the sensor can be determined from its part number designation, engraved on the flange. The interpretation of the part number designation is outlined below.

Length Range

- 1 = 100mm – 500mm
- 2 = 501mm – 1000mm
- 3 = 1001mm – 1500mm
- 4 = 1501mm – 2000mm

Output Type

- K = Voltage (0V – 10V)
- L = Current (4mA – 20mA)

Mounting Arrangement

- A = 1.25" BSP & 5 Bolt SAE
- B = 1.125" UNF & 5 Bolt SAE

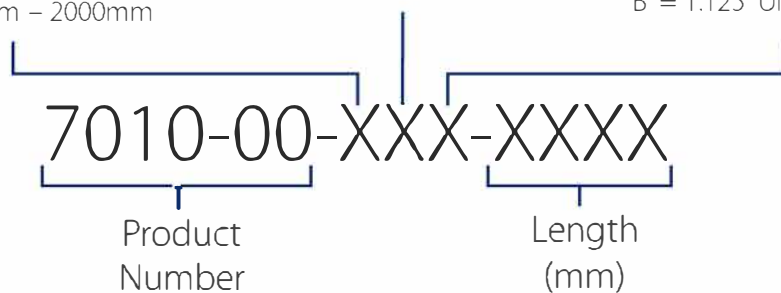

6. MAINTENANCE, RETURNS & DE-COMMISSIONING

6.1 MAINTENANCE

The sensor requires no maintenance. There are no customer serviceable or moving parts within this sensor.

Faults in operation are most likely to occur if the sensor is incorrectly configured during installation. Configuring the measurement output or the tank profiling incorrectly will cause the reported output to be incorrect. A bad configuration may prevent any output being reported.

If any faults with the sensor occur, please contact Gill Sensors & Controls Limited. Contact details can be found on the front of this document.

6.2 RETURNS

If Gill Sensors & Controls Limited require the sensor to be returned, you will be issued with an RMA number. Please DO NOT return the sensor without having first obtained an RMA number. This will enable your sensor to be tracked and updates provided.

6.3 DECOMMISSIONING

To dispose of the sensor, follow local waste disposal regulations.

To uninstall the GSlevel software launch the 'Uninstall GSlevel' application from your program file location selected during installation.

Alternatively, open 'Control Panel > Programs > Programs and Features' and select the 'GSlevel VX.X.X' from the list and select the Uninstall option to remove the GSlevel configurator software from your PC.

7. APPENDIX

Gill Sensors & Controls
EU Declaration of Conformity



In accordance with the following CE Directives:



2014/30/EU (Electromagnetic Compatibility – EMC)
2011/65/EU (Restriction of Hazardous Substances – RoHS)

We, Gill Sensors & Controls Ltd., declare under our sole responsibility that the products:

GS Level 7010 –Liquid Level Sensor (all variants as detailed below):

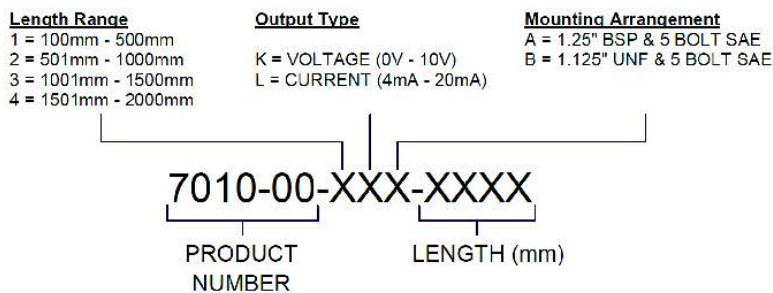

Manufactured by: Gill Sensors & Controls Ltd.
Unit 600 Ampress Park
Lymington,
Hampshire, UK
SO41 8JW

To which this declaration relates, are in conformity with the protection requirements of Council Directive 2014/30/EU on the approximation of the laws relating to electromagnetic compatibility. This Declaration of Conformity is based upon compliance of the product with the following harmonised standards:

Marine	EN 60945: 2002 EN 61326-1: 2013
Light Industrial	EN 61000-6-3: 2007 + A1: 2011 EN 61000-6-4: 2007 + A1: 2011
Measurement Control	EN 61326-2-1: 2013 EN 61000-6-1: 2007
Heavy Industrial	EN 61000-6-2: 2005

Gill Sensors & Controls Limited certifies that the 7010 Liquid Level Sensor is compliant with the European Union's Restriction on the Use of Hazardous Substances in Electrical and Electronic Equipment ("RoHS II") Directive 2011/65/EC by absence of hazardous materials specified herein.

Restriction of Hazardous Substances EN 50581:2012

Signed by: 
Print Name: C. Wright – Director of Group Operations
Date of Issue: 15/05/2017
Place of Issue: Gill Sensors & Controls Ltd, Unit 600 Ampress Park, Lymington, Hampshire, UK SO41 8JW

IMPORTANT NOTICES:

1. Gill Sensors & Controls Limited can take no responsibility for installation and/or use of its equipment if this is not done in accordance with the appropriate issue and/or amendment of the manual.
2. The user of this manual should ensure that it is appropriate in all details to the exact equipment to be installed and/or operated. If in doubt, the user should contact Gill Sensors & Controls Limited for advice.
3. If further details are required which do not appear to in this manual, contact Gill Sensors & Controls Limited or one of their agents.
4. Install and use the 7010 Liquid Level Sensor in accordance with local regulations.
5. Gill Sensors & Controls Limited are continually enhancing their products and specifications and reserve the right to change or revise the information supplied in this document without notice and without obligation to notify any person or organisation of such revision or change.
6. The information contained in this manual remains the property of Gill Sensors & Controls Limited and should not be copied or reproduced for commercial gain.

HELP US TO HELP YOU:

Every effort has been made to ensure the accuracy in the content of our documents, however, Gill Sensors & Controls Limited can assume no responsibility for any errors or omissions in our documents or their consequences. Gill Sensors & Controls Limited would greatly appreciate being informed of any error or omissions that may be found in the contents of any of our documents.

GILL

Gill Sensors & Controls Limited

Unit 600 Ampress Park
Lymington, Hampshire SO41 8LW
United Kingdom

Tel: +44 (0) 1590 613 900
Fax: +44 (0) 1590 613 901
info@gillsc.com

www.gillsc.com

7010-30-086 Iss. 3

Copyright © Gill Sensors & Controls Limited 2018