

Installation Information

RIPS[®] P501 MINIATURE ROTARY SENSOR

Output Option	Output Description:	Supply Voltage: V_s (tolerance)	Load resistance: (include leads for 4 to 20mA O/Ps)
A	0.5 - 4.5V (ratiometric with supply)	+5V (4.5 - 5.5V)	$\geq 5k\Omega$

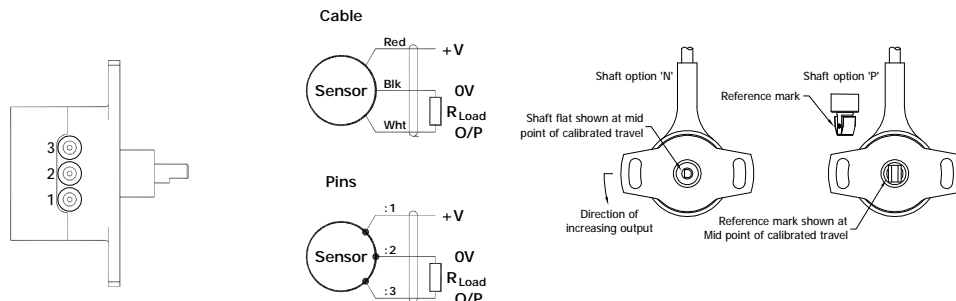

Mechanical Mounting: Flange mounted. The flange slots are 4.5mm by 20 degrees wide, 48mm pitch. The sensor should be mounted with minimal axial and radial loading on the shaft for optimum life. It is recommended that the shaft is coupled to the drive using a flexible coupling.
 Option 'N' shaft: \varnothing 4 mm x 8 mm long, flat 3 mm A/F x 4 mm. Option 'P' shaft: fits 6 x 3 mm slot.

Output Characteristic: The sensor has full rotational freedom and two sectors, 180° apart, over which linear response can be achieved. At the mid point of the calibrated range the output signal will be half full scale deflection, shaft alignment as sketch above. In the calibrated range the output increases as the shaft is rotated in an anti-clockwise direction viewed from the shaft. The calibrated output is factory set to be between 30 and 140°.

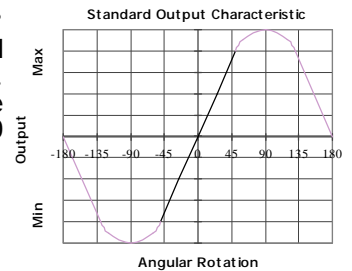

Incorrect Connection Protection levels: **Not protected** – the sensor is **not** protected against either reverse polarity or over-voltage. The risk of damage should be minimal where the supply current is limited to less than 50mA.