

CONNECTORS; WETMATE, 4-POLE.
 BULKHEAD: MC-BH-4-M-SS, STAINLESS STEEL/MOLDED NEOPRENE, SEALING; 340 BAR OPEN FACE, 600 BAR MATED.
 IN-LINE: MC-IL-4-F, MOLDED NEOPRENE WITH CABLE. LOCKING SLEEVE; MCDLS-F, DELRIN.

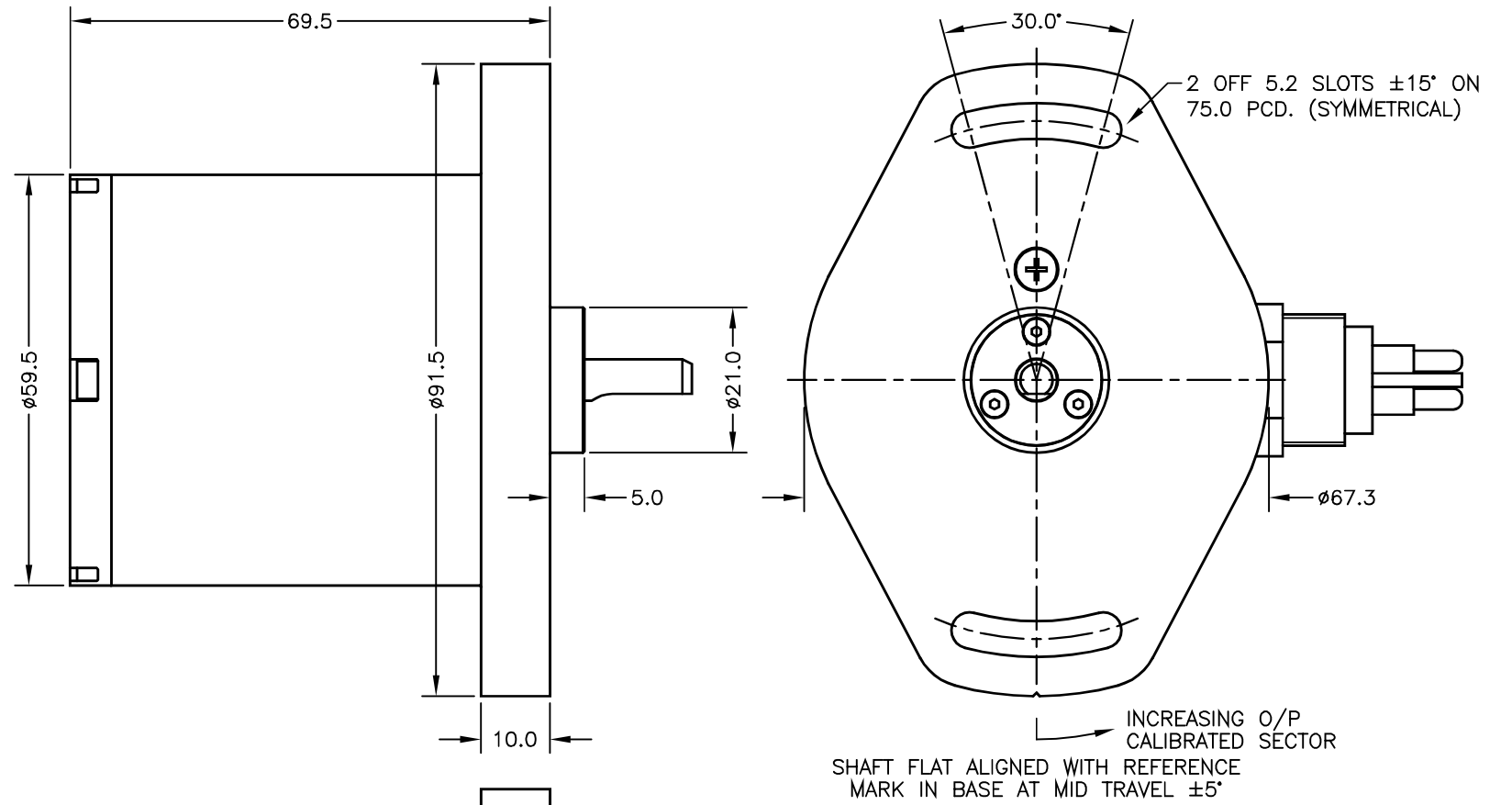
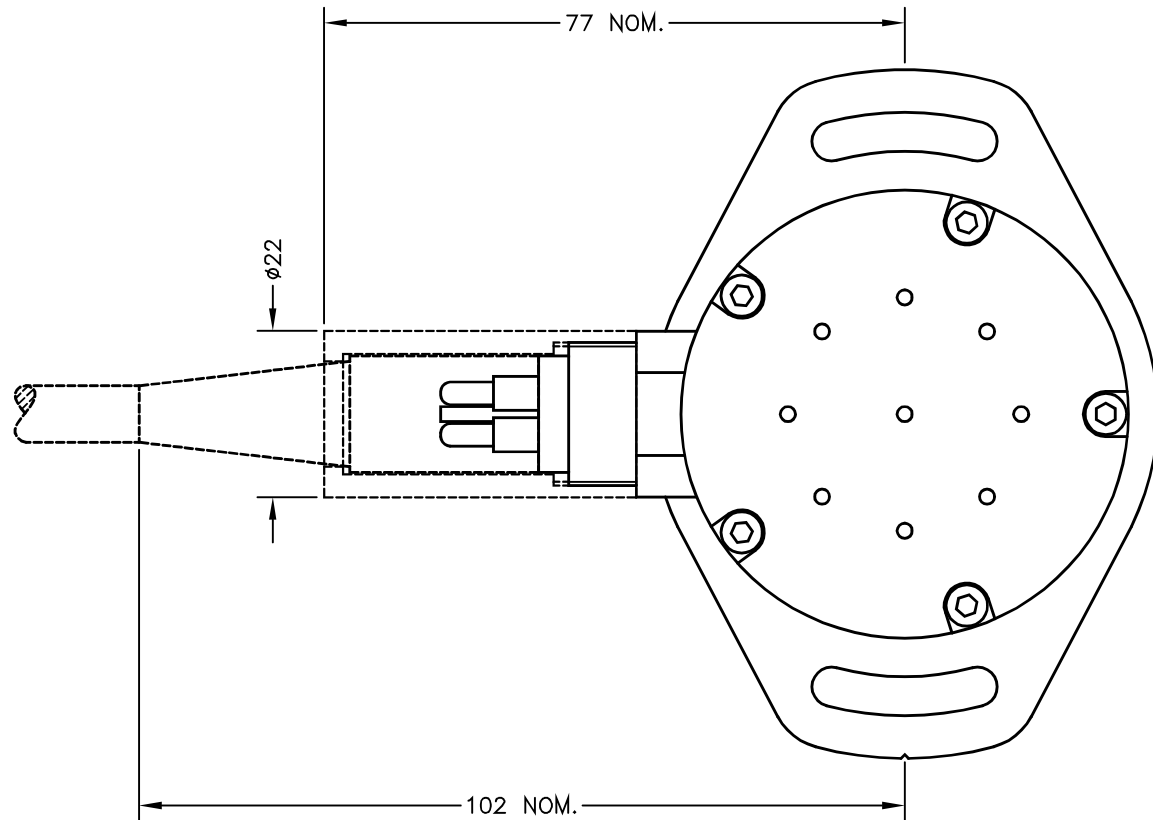

ELECTRICAL OPTIONS/ SPECIFICATIONS	
OUTPUT	SUPPLY
A	0.5 TO 4.5V RATIOMETRIC
B	±5V
C	0.5 TO 9.5V
D	±10V
G	0.5 TO 4.5V
E	4 TO 20mA 2-WIRE
F	4 TO 20mA 3-WIRE SINK
H	4 TO 20mA 3-WIRE SOURCE

SUPPLY: 5V, ±15V, 24V, ±15V, 24V, 24V, 24V, 24V

STANDARD (A, B, C, D)
 BUFFERED (E, F, G, H)

SUPPLY CURRENT 12mA TYP. 20mA MAX.

SINK VERSION OUTPUT COMPLIANCE 5-28V
 SOURCE VERSION DRIVE 300Ω MAX TO 0V

MATING CONNECTOR SUPPLIED WITH 50cm MOULDED CABLE AS STANDARD.
 4-CORE SCREENED: 0.5mm², ø7.5mm MAX. JACKET / CORE INSULATION: EPDM.

- CONNECTIONS:-
- 1 BLACK OUTPUT
 - 2 WHITE 0V
 - 3 RED BODY (OPTIONS: A, C, E-H)
-Ve (OPTIONS: B OR D)
 - 4 GREEN +Ve
- SCREEN NOT CONNECTED TO SENSOR

RANGE OF DISPLACEMENT FROM 0-15° TO 0-160° e.g. 76°, IN INCREMENTS OF 1°.
 BODY MATERIAL:- STAINLESS STEEL 316.

N.b. CONNECTOR ORIENTATION NOT GUARANTEED.

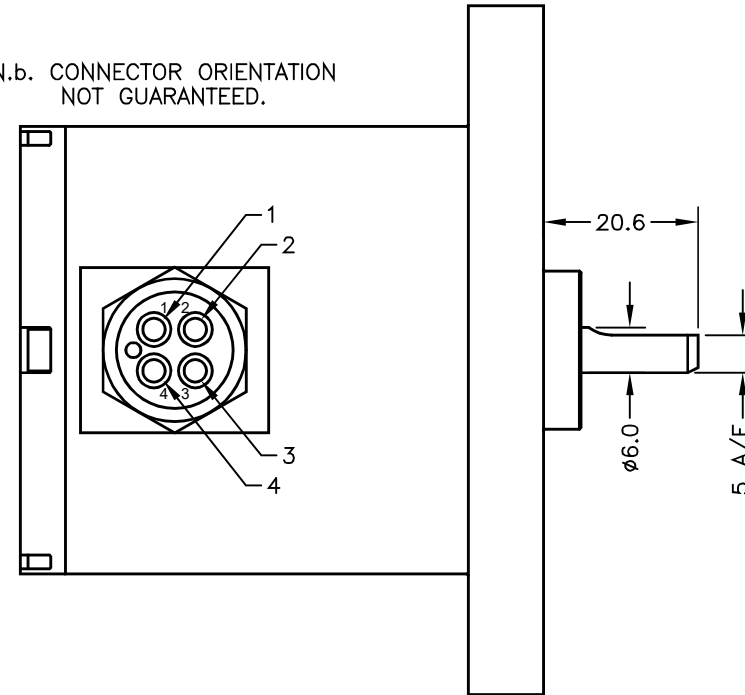

A	FIRST ISSUE.	PDM
B	DISP. FROM 15° WAS 16° - RAN1146	PDM
C	CABLE COLOURS CORRECTED - RAN1190	PDM
D	RANGE NOTE AMENDED ~ RAN1200	PDM



DRAWINGS NOT TO BE CHANGED WITHOUT REFERENCE TO THE CHANGE PROCEDURE.
 CHANGES TO PARTS USED IN INTRINSICALLY SAFE PRODUCT MUST BE APPROVED BY THE AUTHORISED PERSON
 THIS IS AN UNCONTROLLED PRINT AND WILL NOT BE UPDATED.

MAXIMUM WORKING DEPTH: 3500 METRES 350 BAR. WHERE THE FREE END OF THE CABLE IS TO BE TERMINATED IN A SUBMERGED POSITION, ADEQUATE SEALING MUST BE PROVIDED TO PROTECT CONNECTIONS.
 SENSOR IS OIL FILLED AND PRESSURE BALANCED. PRESSURE SENSITIVITY <1%FS TO 350 BAR

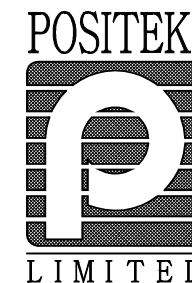

A	27/10/16		CHECKED BY	X	±0.4
B	12/12/16		RDS	X.X	±0.2
C	14/06/17			X.XX	±0.1
D	12/09/17				DIMS mm
DESCRIPTION		S520 350 BAR SUBMERSIBLE ROTARY SENSOR			
SCALE		DRAWING NUMBER S520-11 REV D			
10mm		SHEET 1 OF 1			

RIPS[®] S520 SUBMERSIBLE ROTARY SENSOR

High-resolution angle feedback for industrial and scientific applications

- Non-contacting inductive technology to eliminate wear
- Angle set to customer's requirement
- Durable and reliable
- High accuracy and stability
- Pressure balanced for use to 350 Bar in under water applications

As a leading designer and manufacturer of linear, rotary, tilt and intrinsically safe position sensors, Positek[®] has the expertise to supply a sensor to suit a wide variety of applications.

Our S520 RIPS[®] (Rotary Inductive Position Sensor) is an affordable, durable, high-accuracy rotary sensor designed for arduous underwater applications such as ROVs. The S520, like all Positek[®] sensors, is supplied with the output calibrated to the angle required by the customer, between 15 and 160 degrees and with full EMC protection built in. The sensor provides a linear output characteristic proportional with the rotation of the input shaft. There is a machined registration mark to identify the calibrated mid point.

Overall performance, repeatability and stability are outstanding over a wide temperature range. The S520 has long service life and environmental resistance with a rugged 316 stainless steel body and shaft. The flange mounting makes the sensor easy to install. There are a range of electrical options. Environmental sealing is to IP68 350Bar



SPECIFICATION

Dimensions	
Body Diameter	60 mm, Flange 92 mm
Body Length	70 mm to mounting face
Shaft	15 mm Ø 6 mm
	For full mechanical details see drawing S520-11
Independent Linearity	≤ ± 0.25% FSO @ 20°C - up to 100° travel
	≤ ± 0.1% FSO @ 20°C available upon request.
	*Sensors with calibrated travel up to 100°.
Pressure Effects	Output changes with pressure < 1°
Temperature Coefficients	< ± 0.01%/°C Gain & < ± 0.01%FS/°C Offset
Frequency Response	> 10 kHz (-3dB) (Electrical) > 300 Hz (-3dB) 2 wire 4 to 20 mA
Resolution	Infinite
Noise	< 0.02% FSO
Torque	< 20 mNm Static
Environmental Temperature Limits (Non Icing)	
Operating	-4°C to +50°C
Storage	-4°C to +50°C
Sealing	Sealed to 350 Bar
EMC Performance	EN 61000-6-2, EN 61000-6-3
Vibration	IEC 68-2-6: 10 g
Shock	IEC 68-2-29: 40 g
MTBF	350,000 hrs 40°C Gf
Drawing List	
S520-11	Sensor Outline
Drawings, in AutoCAD [®] dwg or dxf format, available on request.	

Do you need a position sensor made to order to suit a particular installation requirement or specification? We'll be happy to modify any of our designs to suit your needs - please contact us with your requirements.

RIPS[®] S520 SUBMERSIBLE ROTARY SENSOR

High-resolution angle feedback for industrial and scientific applications

How Positek's PIPS[®] technology eliminates wear for longer life

Positek's PIPS[®] technology (Positek Inductive Position Sensor) is a major advance in displacement sensor design. PIPS[®]-based displacement transducers have the simplicity of a potentiometer with the life of an LVDT/RVDT.

PIPS[®] technology combines the best in fundamental inductive principles with advanced micro-electronic integrated circuit technology. A PIPS[®] sensor, based on simple inductive coils using Positek's ASIC control technology, directly measures absolute position giving a DC analogue output signal. Because there is no contact between moving electrical components, reliability is high and wear is eliminated for an exceptionally long life.

PIPS[®] overcomes the drawbacks of LVDT technology - bulky coils, poor length-to-stroke ratio and the need for special magnetic materials. It requires no separate signal conditioning.

Our LIPS[®] range are linear sensors, while RIPS[®] are rotary units and TIPS[®] are for detecting tilt position. Ask us for a full technical explanation of PIPS[®] technology.

We also offer a range of ATEX-qualified intrinsically-safe sensors.

TABLE OF OPTIONS

CALIBRATED TRAVEL: Factory-set to any angle from $\pm 7.5^\circ$ to $\pm 80^\circ$ in increments of 1 degree.
 Full 360° Mechanical rotation.

ELECTRICAL INTERFACE OPTIONS

OUTPUT SIGNAL	SUPPLY INPUT	OUTPUT LOAD
Standard: 0.5-4.5V dc ratiometric	+5V dc nom. \pm 0.5V.	5k Ω min.
Buffered: 0.5-4.5V dc	+24V dc nom. + 9-28V.	5k Ω min.
\pm 5V dc	\pm 15V dc nom. \pm 9-28V.	5k Ω min.
0.5-9.5V dc	+24V dc nom. + 13-28V.	5k Ω min.
\pm 10V dc	\pm 15 V dc nom. \pm 13.5-28V.	5k Ω min.
Supply Current	10mA typical, 20mA maximum.	
4-20mA (2 wire)	+24 V dc nom. + 18-28V.	300 Ω @ 24V.
(3 wire sink)	+24 V dc nom. + 13-28V.	950 Ω @ 24V.
(3 wire source)	+24 V dc nom. + 13-28V.	300 Ω max.

CONNECTOR

Wet mate 4 pin MC BH-4-M
 Supplied with a connector and 0.5 m, 4x0.5mm² cable assembly as standard.
 Mating connector with longer lengths available.

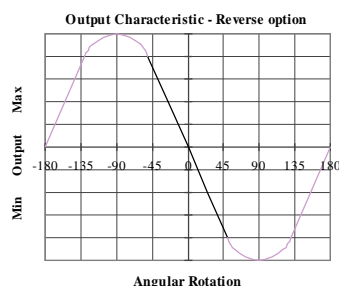
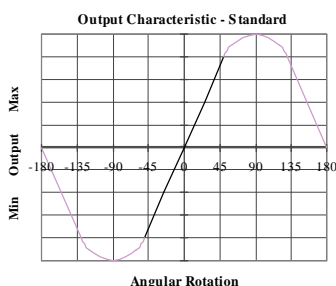

For further information please contact:

www.positek.com sales@positek.com

Tel: +44(0)1242 820027 fax: +44(0)1242 820615

Positek Ltd, Andoversford Industrial Estate, Cheltenham GL54 4LB U.K.



S520-17d

RIPS® SERIES S520 Submersible Rotary Sensor

a	b	c	d
S520	Displacement Output	K50	Z-code

a Displacement (degrees)		Value
Displacement in degrees	e.g. 0 - 54 degrees	54
b Output		
Supply V dc V _s (tolerance)	Output	Code
+5V (4.5 - 5.5V)	0.5 - 4.5V (ratiometric with supply)	A
±15V nom. (±9 - 28V)	±5V	B
+24V nom. (13 - 28V)	0.5 - 9.5V	C
±15V nom. (±13.5 - 28V)	±10V	D
+24V nom. (18 - 28V)	4 - 20mA 2 wire	E
+24V nom. (13 - 28V)	4 - 20mA 3 wire Sink	F
+24V nom. (9 - 28V)	0.5 - 4.5V	G
+24V nom. (13 - 28V)	4 - 20mA 3 wire Source	H
c Connections		Code
Connector	IP68 350 Bar Wet mate 4 pin MC BH-4-M plus pre-wired mating connector with 50 cm 4-core cable.	K50
d Z-code		Code
≤± 0.1% @20°C Independent Linearity displacement up to 100 degrees only!		Z650

Installation Information

RIPS® S520 350 BAR SUBMERSIBLE ROTARY SENSOR

Output Option	Output Description:	Supply Voltage: V_s (tolerance)	Load resistance: (include leads for 4 to 20mA O/Ps)
A	0.5 - 4.5V (ratiometric with supply)	+5V (4.5 - 5.5V)	$\geq 5k\Omega$
B	$\pm 5V$	$\pm 15V$ nom. ($\pm 9 - 28V$)	$\geq 5k\Omega$
C	0.5 - 9.5V	+24V nom. (13 - 28V)	$\geq 5k\Omega$
D	$\pm 10V$	$\pm 15V$ nom. ($\pm 13.5 - 28V$)	$\geq 5k\Omega$
E	4 - 20mA 2 wire Current Loop	+24V nom. (18 - 28V)	$\approx 0 - 300\Omega$ max. @24V ~ 1.2 to 6V across 300 Ω { R_L max. = $(V_s - 18) / 20^{-3}$ }
F	4 - 20mA 3 wire Sink	+24V nom. (13 - 28V)	$\approx 0 - 950\Omega$ max. @24V ~ 3.8 to 19V across 950 Ω { R_L max. = $(V_s - 5) / 20^{-3}$ }
G	0.5 - 4.5V	+24V nom. (9 - 28V)	$\geq 5k\Omega$
H	4 - 20mA 3 wire Source	+24V nom. (13 - 28V)	$\approx 0 - 300\Omega$ max. ~ 1.2 to 6V across 300 Ω

Connector Pin Layout:
 MC BH 4 M (face view)

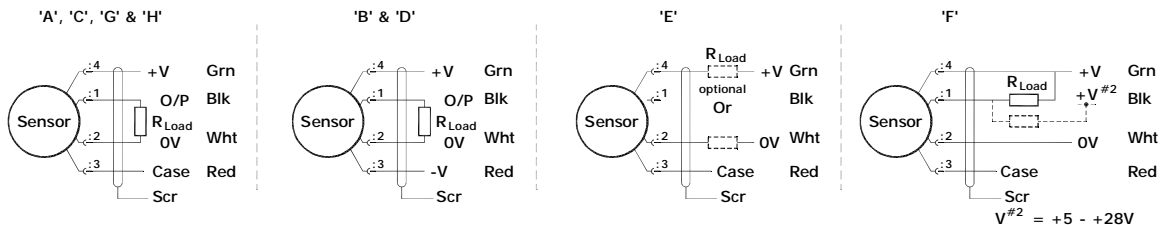

Mechanical Mounting: Flange mounted with two M5 screws through slots which allow +/- 15° angular adjustment. The sensor should be mounted with minimal axial and radial loading on the shaft for optimum life. It is recommended that the shaft is coupled to the drive using a flexible coupling. Tests indicate that life in excess of 16 million cycles can be achieved with 1kg side and end load.

N.b. cable free end must be appropriately terminated to prevent water ingress into the cable. See page 2 for connector handling instructions. The sensor is sealed to IP68 350 Bar.

Warning Do not tamper with any of the case screws; the oil fill will be compromised.

Output Characteristic: The sensor has full rotational freedom and two sectors, 180° apart, over which linear response can be achieved. At the mid point of the calibrated range the output signal will be half full scale deflection, and the flat on the shaft is aligned with the registration mark in the base of the sensor. In the calibrated range the output increases as the shaft is rotated in an anti-clockwise direction viewed from the shaft. The calibrated output is factory set to be between 15° and 160°.

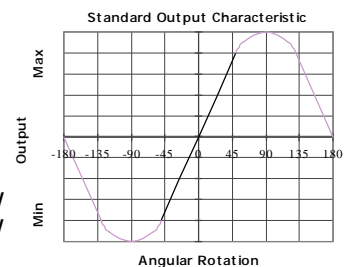

Incorrect Connection Protection levels:-

- A **Not protected** – the sensor is **not** protected against either reverse polarity or over-voltage. The risk of damage should be minimal where the supply current is limited to less than 50mA.
- B & D Supply leads diode protected. Output must not be taken outside $\pm 12V$.
- C & G Supply leads diode protected. Output must not be taken outside 0 to 12V.
- E, F & H Protected against any misconnection within the rated voltage.



For further information please contact:
www.positek.com sales@positek.com
 Tel: +44(0)1242 820027 fax: +44(0)1242 820615
 Positek Ltd, Andoversford Industrial Estate, Cheltenham GL54 4LB. U.K.



Installation Information

RIPS® S520 350 BAR SUBMERSIBLE ROTARY SENSOR

Handling

- Always apply grease before mating
- Disconnect by pulling straight, not at an angle
- Do not pull on the cable and avoid sharp bends at cable entry
- When using a bulkhead connector, ensure that there are no angular loads
- Do not over-tighten the bulkhead nuts
- SubConn® connectors should not be exposed to extended periods of heat or direct sunlight. If a connector becomes very dry, it should be soaked in fresh water before use

Cleaning

- General cleaning and removal of any accumulated sand or mud on a connector should be performed using spray based contact cleaner (isopropyl alcohol)
- New grease must be applied again prior to mating

Greasing and mating above water (dry mate)

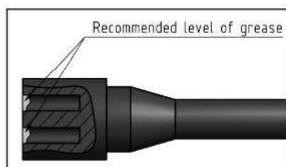

- Connectors must be greased with Molykote 44 Medium before every mating
- A layer of grease corresponding to minimum 1/10 of socket depth should be applied to the female connector
- The inner edge of all sockets should be completely covered, and a thin transparent layer of grease left visible on the face of the connector
- After greasing, fully mate the male and female connector in order to secure optimal distribution of grease on pins and in sockets
- To confirm that grease has been sufficiently applied, de-mate and check for grease on every male pin. Then re-mate the connector

Greasing and mating under water (wet mate)

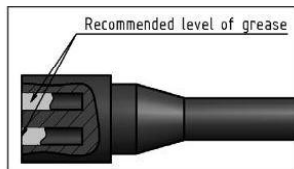

- Connectors must be greased with Molykote 44 Medium before every mating
- A layer of grease corresponding to approximately 1/3 of socket depth should be applied to the female connector
- All sockets should be completely sealed, and transparent layer of grease left visible on the face of the connector
- After greasing, fully mate the male and female connector and remove any excess grease from the connector joint