

Temperature Probe ETP-MO-SP-1/8NPT



Eurosensor

ETP-MO-SP-1/8NPT-30-PT1000A

- Cost effective standard model
- Robust and compact design
- For harsh environments
- Wide environmental temperature range



The ETP-MO-SP has been specifically designed for demanding temperature measurement tasks as can be found in motor vehicles. The probe is designed to withstand shock and vibration due to a robust overall construction. The selected materials are oil and fuel resistant for use in typical mobile applications whilst supporting a wide environmental temperature range.

Technical information

Element:	PT1000A other elements on request
Accuracy:	$\pm (0.15 K + 0,002 \times t)$
Working temperature:	-40° C to +230° C
Environmental temperature:	-40° C to +150° C
Recommend applied current (self heating must be considered)	1 mA at 100 Ω 0.3 mA at 1000 Ω

Sealing:	IP67
Housing:	316 stainless steel
Cable:	2 core AWG 20 oil/fuel resistant cable with stainless steel braid

Dimensions in mm

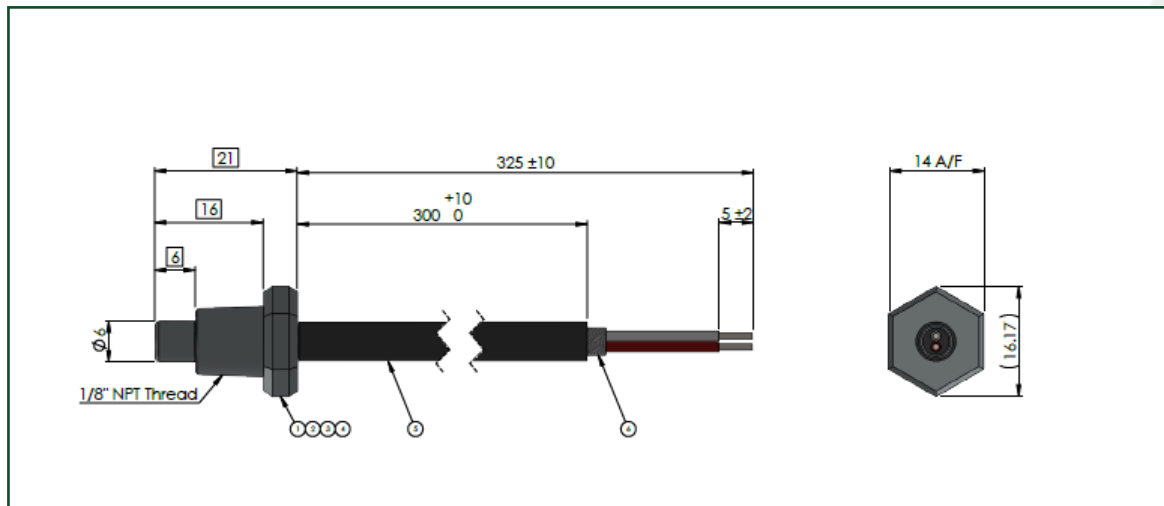

Ordering Information

Order code: 94787-ETP-MO-SP-1/8NPT-30-PT1000A



Variohm EuroSensor - Williams' Barn - Tiffeld Road - Towcester - Northants - NN12 6HP - UK
sales@variohm.com • www.variohm.com • +44 (0) 1327 351004

Subject to change without notice