

CONNECTORS; MICRO MINI WETMATE, 4-POLE.  
 BULKHEAD; MCBH-4-MP-SS, STAINLESS STEEL/MOLDED NEOPRENE, SEALING; 340 BAR OPEN FACE, 600 BAR MATED.  
 IN-LINE; MCIL-4-FS, MOLDED NEOPRENE WITH CABLE. LOCKING SLEEVE; MCDLS-F, DELRIN.

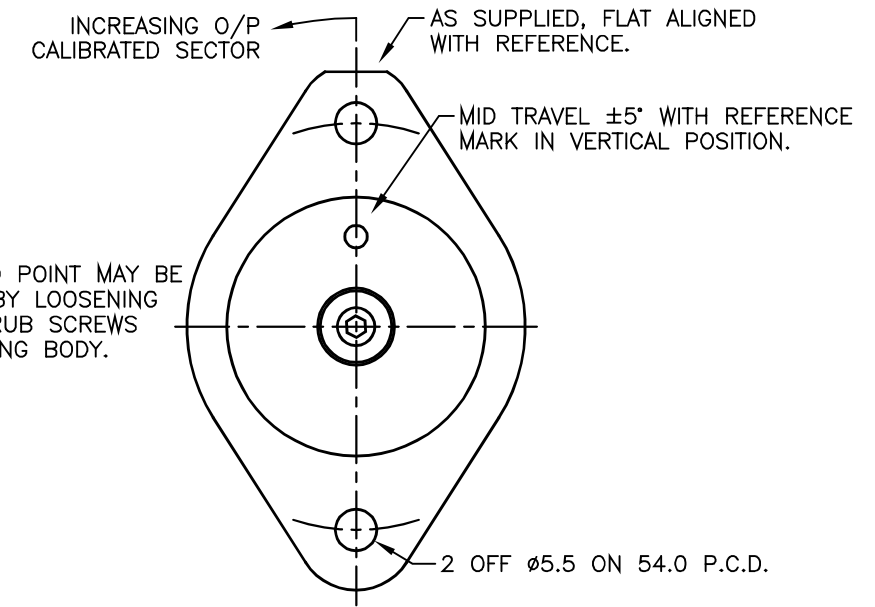
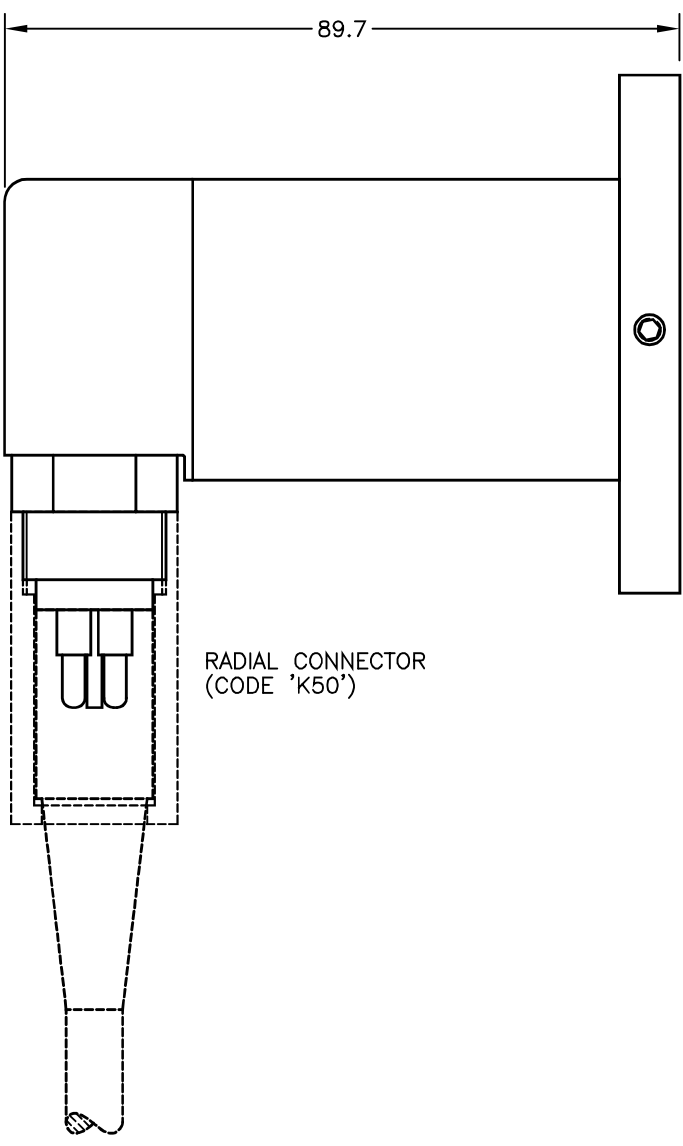
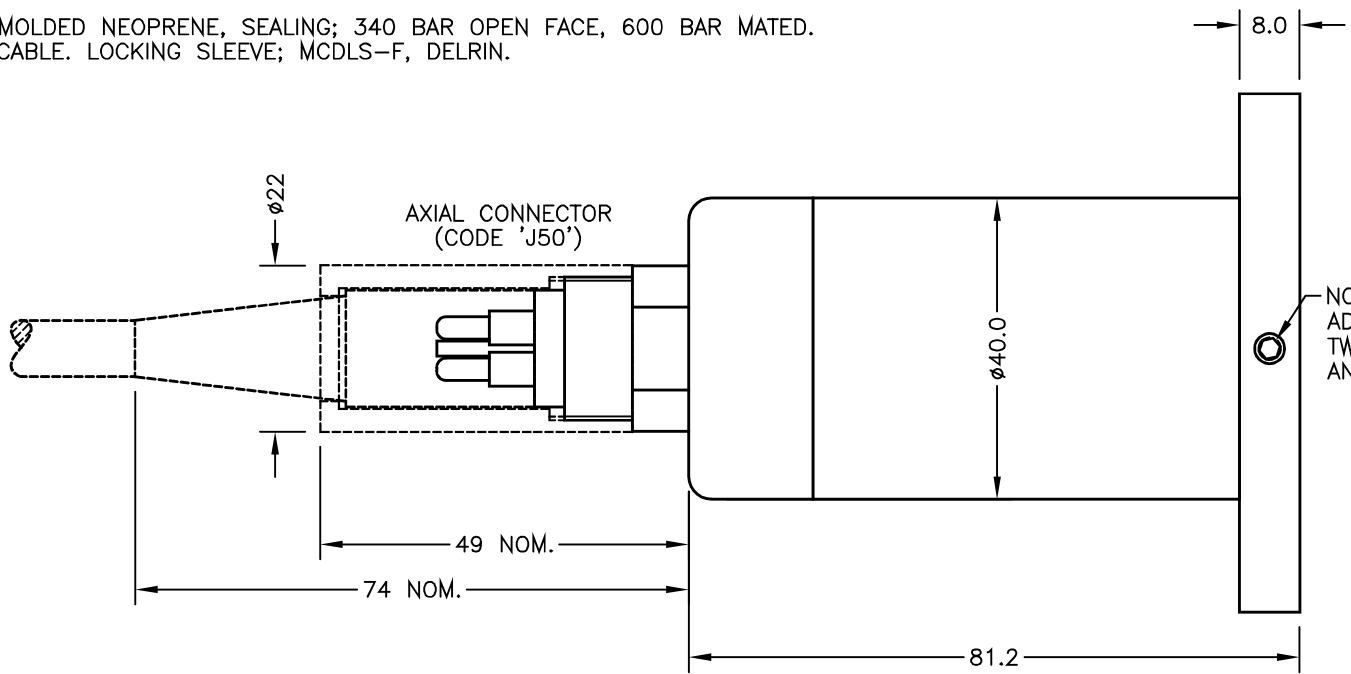
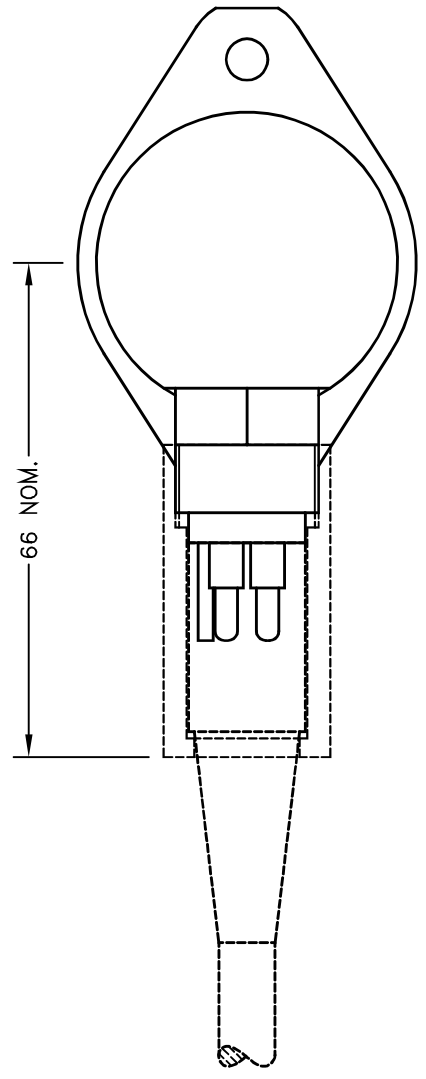
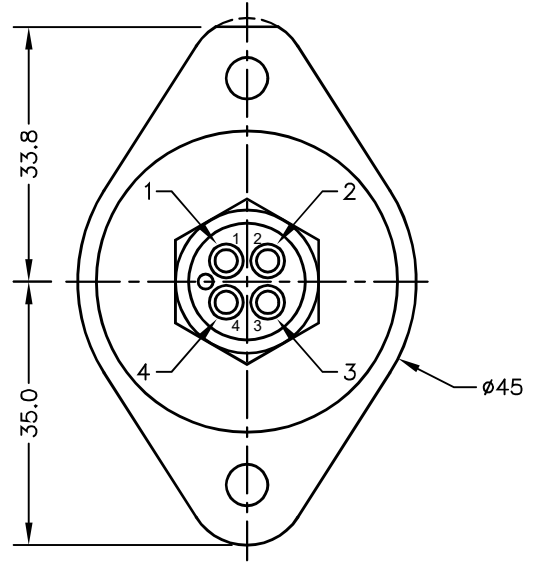

**ELECTRICAL OPTIONS/ SPECIFICATIONS**

OUTPUT	SUPPLY
0.5 TO 4.5V RATIOMETRIC	5V
SUPPLY CURRENT 12mA TYP.	20mA MAX.

MATING CONNECTOR (CODE 'J50' OR 'K50') SUPPLIED WITH 50cm MOULDED CABLE AS STANDARD.  
 4-CORE SCREENED: 0.5mm<sup>2</sup>, ø7.5mm MAX. JACKET AND CORE INSULATION: EPDM.

CONNECTIONS:-

1	BLACK	OUTPUT
2	WHITE	OV
3	RED	BODY
4	GREEN	+Ve
	SCREEN	NOT CONNECTED TO SENSOR

RANGE OF DISPLACEMENT FROM 0-15° TO 0-160° e.g. 76°, IN INCREMENTS OF 1°.  
 BODY MATERIAL: STAINLESS STEEL 316.

NOTE:- READ INSTALLATION SHEET X623-19 FOR FULL INSTRUCTIONS FOR USE.

ATEX / IECEx APPROVED TO

II 1G

Ex ia IIC T4 Ga (Ta= -40° to +80°C)  
 Ui 11.4V, Ii 0.2A, Pi 0.51W

APPROVED FOR USE IN CONJUNCTION WITH A GALVANICALLY ISOLATED BARRIER.

NOTE: APPROVAL ONLY APPLIES AT NORMAL ATMOSPHERIC PRESSURE!

A	FIRST ISSUE.	RDS
B	RADIAL CONN ADDED - RAN1129.	PDM
C	CABLE COLOURS CORRECTED - RAN1190	PDM
D	RANGE NOTE AMENDED ~ RAN1200	PDM



MAXIMUM WORKING DEPTH: 3500 METRES 350 BAR. WHERE THE FREE END OF THE CABLE IS TO BE TERMINATED IN A SUBMERGED POSITION, ADEQUATE SEALING MUST BE PROVIDED TO PROTECT CONNECTIONS.

DRAWINGS NOT TO BE CHANGED WITHOUT REFERENCE TO THE CHANGE PROCEDURE. CHANGES TO PARTS USED IN INTRINSICALLY SAFE PRODUCT MUST BE APPROVED BY THE AUTHORISED PERSON  
 THIS IS AN UNCONTROLLED PRINT AND WILL NOT BE UPDATED.

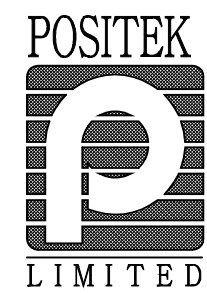

A	15/09/15		CHECKED BY	X	±0.4
B	12/12/16		RDS	X.X	±0.2
C	14/06/17			X.XX	±0.1
D	13/09/17				DIMS mm
		DESCRIPTION		INTRINSICALLY SAFE 350 BAR SUBMERSIBLE LARGE ANGLE TILT SENSOR	
SCALE 10mm		DRAWING NUMBER		X623-11	
				REV	D
				SHEET 1 OF 1	

# TIPS® X623 LARGE ANGLE SUBMERSIBLE TILT SENSOR INTRINSICALLY SAFE FOR HAZARDOUS GAS/VAPOUR ATMOSPHERES

- Intrinsically safe for Gas to:  
Ex II 1G
- Non-contacting inductive technology to eliminate wear
- Angle set to customer's requirement
- Compact and self-contained
- High durability and reliability
- High accuracy and stability
- Sealing to IP68 350 Bar



As a leading designer and manufacturer of linear, rotary, tilt and intrinsically safe position sensors, Positek® has the expertise to supply a sensor to suit a wide variety of applications.

Our X623 TIPS® (Tilt Inductive Position Sensor) incorporates electronics system EX07 which is ATEX / IECEx approved for use in potentially explosive gas/vapour atmospheres.

The X623 is designed to provide feedback for arduous underwater applications, such as ROVs, where hazardous surface conditions may exist. The X623, like all Positek® sensors, is supplied with the output calibrated to the angle required by the customer, between 15 and 160 degrees and with full EMC protection built in. The sensor provides a linear output proportional with the rotation of the sensor. There is a machined registration mark to identify the calibrated mid point.

Overall performance, repeatability and stability are outstanding over a wide temperature range. Electrical connections to the sensor are made via a wet mate connector.

The sensor has a rugged 316 stainless steel body and mounting flange. The flange has two 5.5mm holes on a 54mm pitch to simplify mounting. The X623 offers a range of electrical options. Environmental sealing is to IP68 350 Bar.

## SPECIFICATION

<b>Dimensions</b>	
Body Diameter	40 mm, Flange 69 mm
Body Length (to seal face)	81 mm
For full mechanical details see drawing X623-11	
<b>Power Supply</b>	+5V dc nom. ± 0.5V, 10mA typ 20mA max
<b>Output Signal</b>	0.5-4.5V dc ratiometric, Load: 5kΩ min.
<b>Independent Linearity/Hysteresis</b> (combined error)	< ± 0.25° - up to 100°
<b>Temperature Coefficients</b>	< ± 0.01%/°C Gain & < ± 0.01%FS/°C Offset
<b>Response Time</b>	250 ms @ 20°C typ.
<b>Resolution</b>	Infinite
<b>Damping Ratio</b>	0.2 : 1 (0.6 nom. @ 25°C
<b>Noise</b>	< 0.02% FSO
<b>Intrinsic Safety</b>	Ex II 1G Ex ia IIC T4 Ga (Ta= -40°C to 80°C)
Approval only applies to the specified ambient temperature range and atmospheric conditions in the range 0.80 to 1.10 Bar, oxygen ≤ 21%	
<b>Sensor Input Parameters</b>	Ui: 11.4V, Ii: 0.20A, Pi: 0.51W.
(without cable)	Ci: 1.16µF, Li: 50µH
(with cable)	Ci: 1.36µF, Li: 860µH with 1km max. cable
<b>Environmental Temperature Limits</b>	
Operating	-4°C to +50°C
Storage	-4°C to +50°C
<b>Sealing</b>	IP68 350Bar
<b>EMC Performance</b>	EN 61000-6-2, EN 61000-6-3
<b>Vibration</b>	IEC 68-2-6: 10 g
<b>Shock</b>	IEC 68-2-29: 0 g
<b>MTBF</b>	350,000 hrs 40°C Gf
<b>Drawing List</b>	
X623-11	Sensor Outline
Drawings, in AutoCAD® dwg or dxf format, available on request.	

Do you need a position sensor made to order to suit a particular installation requirement or specification? We'll be happy to modify any of our designs to suit your needs - please contact us with your requirements.

# TIPS<sup>®</sup> X623 LARGE ANGLE SUBMERSIBLE TILT SENSOR INTRINSICALLY SAFE FOR HAZARDOUS GAS/VAPOUR ATMOSPHERES

Intrinsically safe equipment is defined as "equipment which is incapable of releasing sufficient electrical or thermal energy under normal or abnormal conditions to cause ignition of a specific hazardous atmosphere mixture in its most easily ignited concentration."

ATEX / IECEx approved to;  
 Ex II 1G  
 Ex ia IIC T4 Ga (Ta = -40°C to +80°C)

Designates the sensor as belonging to; Group II: suitable for all areas **except mining**, Category 1 G: can be used in areas with continuous, long or frequent periods of exposure to hazardous gas (Zone 0).

Protection class ia, denotes intrinsically safe for all zones Apparatus group IIC: suitable for IIA to IIC explosive gas. Temperature class T4: maximum surface temperature under fault conditions 135°C.

Ambient temperature range extended to -40°C to +80°C.

It is imperative Positek<sup>®</sup> intrinsically safe sensors be used in conjunction with a galvanic barrier to meet the requirements of the product certification. The Positek X005 Galvanic Isolation Amplifier is purpose made for Positek IS sensors making it the perfect choice. Refer to the X005 datasheet for product specification and output configuration options.

#### Safety Parameters:-

Ui: 11.4V, Ii: 0.20A, Pi: 0.51W  
 Ci = 1.36µF\* Li = 860µH\* (with cable)  
 Ci = 1.16µF Li = 50µH (without cable)

\*Figures for 1km cable where: Ci = 200pF/m & Li = 810nH/m

Sensors can be installed with a maximum of 1000m of cable.

Cable characteristics must not exceed:-

Capacitance: ≤ 200 pF/m for max. total of: 200 nF.  
 Inductance: ≤ 810 nH/m for max. total of: 810 µH

For cable lengths exceeding 10 metres a five wire connection is recommended to eliminate errors introduced by cable resistance and associated temperature coefficients.

#### TABLE OF OPTIONS

**CALIBRATED TRAVEL:** Factory-set to any angle from ±7.5° to ±80° in increments of 1°.  
 Full 360° Mechanical rotation.

#### ELECTRICAL INTERFACE OPTIONS

The Positek<sup>®</sup> X005 Galvanic Isolation Amplifier is available with the following output options;

Standard: 0.5 - 9.5V or 4 - 20mA.  
 Reverse: 9.5 - 0.5V or 20 - 4mA.

#### CONNECTOR

Wet mate 4 pin MC BH-4-M (axial or radial)  
 Supplied with a connector and 0.5 m, 4x0.5mm<sup>2</sup> cable assembly as standard.  
 Mating connector with longer lengths available.

We recommend all customers refer to the 3 or 5-Wire Mode Connection page.

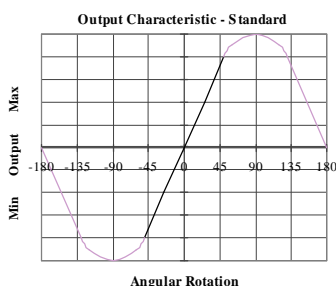

For further information please contact:  
[www.positek.com](http://www.positek.com) [sales@positek.com](mailto:sales@positek.com)  
 Tel: +44(0)1242 820027 fax: +44(0)1242 820615  
 Positek Ltd, Andoversford Industrial Estate, Cheltenham GL54 4LB U.K.



X623-17d

# Three or Five-Wire Mode Connection FOR INTRINSICALLY SAFE SENSORS IN HAZARDOUS ATMOSPHERES

The aim of this document is to help readers who do not understand what is meant by three or five wire modes of connection between the galvanic isolation amplifier and sensor, and the factors behind them. It is by no means an in-depth technical analysis of the subject.

Interconnecting cables are not perfect conductors and offer resistance to current flow, the magnitude of resistance<sup>†</sup> depends on conductors resistivity, which changes with temperature, cross sectional area<sup>‡</sup> and length. If the voltage were to be measured at both ends of a length of wire it would be found they are different, this is known as volts drop. Volts drop changes with current flow and can be calculated using Ohm's law, it should be noted that volts drop occurs in both positive and negative conductors. The effects of volts drop can be reduced by increasing the conductors cross sectional area, this does not however eliminate the effects due to temperature variation. There are situations where large cross-section cables are not practical; for example copper prices and ease of installation.

This is important because the effects of volts drop can significantly alter the perceived accuracy of the sensor which is ratiometric i.e. the output signal is directly affected by the voltage across the sensor. Changes in temperature will also be seen as gain variation in the sensor output.

**Three wire mode** connections are common and are suitable in most cases with short or moderate cable runs. Applications that do not require a high degree of accuracy but have cable runs, say in excess of 20m, volts drop can be reduced by introducing a terminal box close to the sensor and using a larger cross-section cable for a majority of the cable run. Sensors are supplied calibrated via a wet mate connector and cable assembly which largely eliminates errors due to conductor resistance at room temperature however, as mentioned above, small gain errors due to temperature fluctuations should be expected.

**Five wire mode** connections have significant benefits as losses in the positive and negative conductors are compensated for by the galvanic isolation amplifier which can 'sense' the voltage across the sensor and dynamically adjust the output voltage so that the voltage across the sensor is correct. The effects of cable resistance and associated temperature coefficients are eliminated allowing for smaller conductors than a three wire connection for the same cable run. The amplifier can compensate for up to 15Ω per conductor with a current flow of 15mA, which is more than adequate for 300m of 0.5 mm<sup>2</sup> cable, longer lengths will require larger conductors.

For this reason Positek® recommends five wire connections for cable lengths exceeding 20 metres in 0.5 mm<sup>2</sup> cable to preserve the full accuracy of the sensor.

Positek® submersible sensors are supplied with a wet mate connector and four core 0.5 mm<sup>2</sup> cable assembly as standard.

See illustrations below for examples of connecting a sensor to the galvanic isolation amplifier.

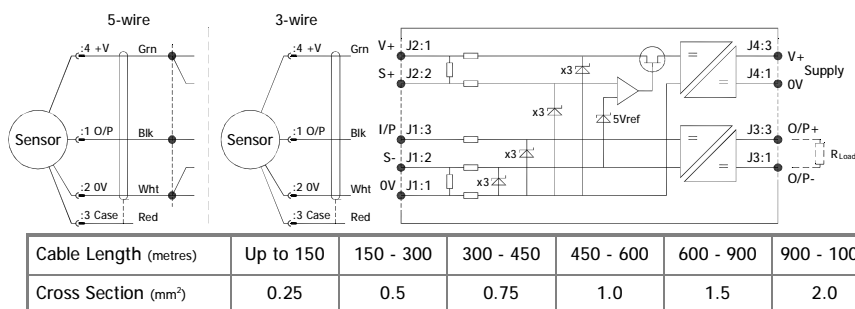

The table above shows recommended conductor sizes with respect to cable length for both three and five wire connections, based on copper conductors. Three wire connections will introduce a gain reduction of 5% and a ±1% temperature dependence of gain over the range -40°C to +80°C for the cable temperature. (i.e. about -150 ppm/°C for the maximum lengths shown and less pro rata for shorter lengths.)

It should be noted that the maximum cable length, as specified in the sensor certification, takes precedence and must not be exceeded.

The galvanic isolation amplifier is available as;

G005-\*\*\* for 'G' prefix sensors  
 X005-\*\*\* for 'X' prefix sensors

<sup>†</sup>  $R = \rho L/A$   $\rho$  is the resistivity of the conductor ( $\Omega m$ )  $L$  is the length of conductor (m)  $A$  is the conductor cross-sectional area (m<sup>2</sup>).

<sup>‡</sup> It is presumed that direct current flow is uniform across the cross-section of the wire, the galvanic isolation amplifier and sensor are a dc system.

# Intrinsically Safe - Gas/Vapour Atmospheres

## TIPS® SERIES X623 Large Angle Submersible Tilt Sensor

a	b	c	d	e
X623	Displacement	A	Y	Connections Z-code

a Displacement (degrees)		Value
Displacement in degrees	e.g. 0 - 54 degrees	54
b Output		
Supply V dc V <sub>s</sub> (tolerance)	Output	Code
+5V (4.5 - 5.5V)	0.5 - 4.5V (ratiometric with supply)	A
c Calibration Adjustments		Code
Sealed		Y
d Connections		Code
Connector - Axial	IP68 350 Bar Wet mate 4 pin MC	J50
Connector - Radial	BH-4-M plus pre-wired mating connector	K50
e Z-code		Code
Calibration to suit X005 - Default		Z000

### Note!

All Intrinsically Safe (IS) sensors must have a Z-code suffix.

IS sensors must be used in conjunction with a Galvanic Isolation Amplifier - See X005 for Output options.

# Installation Information

## TIPS<sup>®</sup> X623 LARGE ANGLE SUBMERSIBLE TILT SENSOR INTRINSICALLY SAFE FOR HAZARDOUS GAS/VAPOUR ATMOSPHERES

ATEX /IECEx Qualified to Intrinsic Safety Standard Certificate numbers SIRA 13ATEX2371X IECEx SIR 13.0154X		Ex II 1G Ex ia IIC T4 Ga (Ta = -40°C to +80°C)	
Electronics Version	Output Description:	Supply Voltage: V <sub>s</sub> (tolerance)	Load resistance:
EX07	0.5 - 4.5V (ratiometric with supply) [Output code 'A']	+5V (4.5 - 5.5V)	5kΩ min

Connector Pin Layout:  
MC BH 4 M (face view)

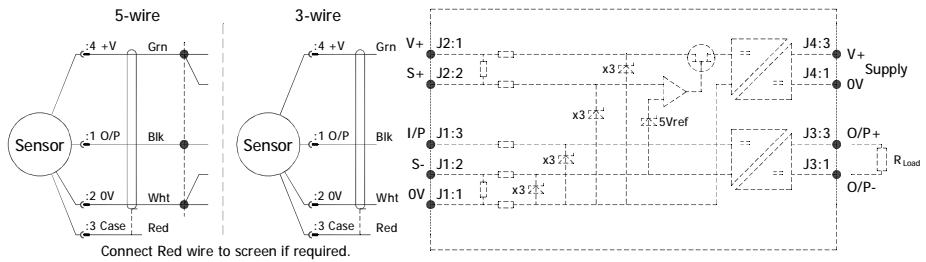

**Putting Into Service:** The sensor must be used with a galvanic isolation barrier designed to supply the sensor with a nominal 5V and to transmit the sensor output to a safe area. The barrier parameters must not exceed:-

$U_i = 11.4V$        $I_i = 0.20A$        $P_i = 0.51W$   
 $C_i = 1.36\mu F^*$        $L_i = 860\mu H^*$  (with cable)      \*Figures for 1km cable  
 $C_i = 1.16\mu F$        $L_i = 50\mu H$  (without cable)

The sensor is certified to be used with up to 1000m of cable, cable characteristics must not exceed:-

Capacitance: ≤ 200 pF/m for max. total of: 200 nF  
 Inductance: ≤ 810 nH/m for max. total of: 810 μH

Approval only applies to specified ambient temperature range and atmospheric conditions in the range: 0.80 to 1.10 Bar, oxygen ≤ 21%.

The performance of the sensor may be affected by voltage drops associated with long cable lengths; for cable runs exceeding 10 metres a five wire connection is recommended to eliminate errors introduced by cable resistance and associated temperature coefficients.

N.b. Cable free end must be appropriately terminated, including preventing water ingress into the cable.

See page 2 for connector handling instructions.

The sensor is sealed to IP68 350 Bar.

**Special Condition for Safe Use:**

The apparatus does not meet the 500 V r.m.s dielectric strength test between circuit and frame, in accordance with clause 6.3.13 of IEC 60079-11:2011. This must be taken into consideration on installation.

When using a Sensor that has an integral cable in a dust application, the free end of the cable shall be appropriately terminated for the zone of use.

Under certain extreme circumstances, the non-metallic and isolated metal parts incorporated in the enclosure of this equipment may generate an ignition-capable level of electrostatic charge. Therefore the equipment shall not be installed in a location where the external conditions are conducive to the build-up of electrostatic charge on such surfaces. This is particularly important if the equipment is installed in a zone 0 location. In addition, the equipment shall only be cleaned with a damp cloth.

**Use:** The sensor is designed to measure rotational displacement and provide an analogue output signal.

**Assembly and Dismantling:** The unit is not to be serviced or dismantled and re-assembled by the user.

**Maintenance:** No maintenance is required. Any cleaning must be done with a damp cloth.

**Mechanical Mounting:** Flange mounted, flange holes are 5.5mm diameter on a 54mm pitch. As shipped, the sensor calibrated mid-point will be obtained with the flange in the vertical plane, as shown. Mechanical adjustment of the mid point can be achieved by loosening two M4 grub screws in the edge of the flange and rotating the sensor body. **Note:** the sensor should be mounted on a vertical face.

**Output Characteristic:** The sensor has full rotational freedom and two sectors, 180° apart, over which linear response can be achieved. At the mid point of the calibrated range the output signal will be half full scale deflection, and the mounting flanges will be vertical. In the calibrated range the output increases as the sensor is rotated in an anti-clockwise direction viewed from the flange face - see drawing above. The calibrated output is factory set to be between 15 and 160°.

**Incorrect Connection Protection levels:-** The sensor is not protected against either reverse polarity or over-voltage. The risk of damage should be minimal where the supply current is limited to less than 50mA.

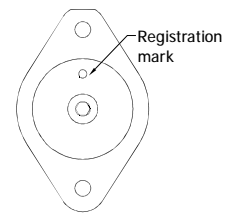

Direction of increasing output in calibrated sector

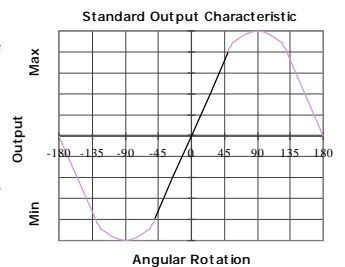

For further information please contact:  
[www.positek.com](http://www.positek.com) [sales@positek.com](mailto:sales@positek.com)

Tel: +44(0)1242 820027 fax: +44(0)1242 820615

Positek Ltd, Andoversford Industrial Estate, Cheltenham GL54 4LB. U.K.

# Installation Information

## TIPS<sup>®</sup> X623 LARGE ANGLE SUBMERSIBLE TILT SENSOR INTRINSICALLY SAFE FOR HAZARDOUS GAS/VAPOUR ATMOSPHERES

### Handling

- Always apply grease before mating
- Disconnect by pulling straight, not at an angle
- Do not pull on the cable and avoid sharp bends at cable entry
- When using a bulkhead connector, ensure that there are no angular loads
- Do not over-tighten the bulkhead nuts
- SubConn<sup>®</sup> connectors should not be exposed to extended periods of heat or direct sunlight. If a connector becomes very dry, it should be soaked in fresh water before use

### Greasing and mating above water (dry mate)

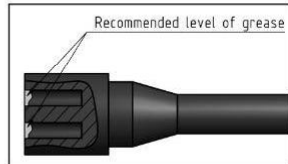

- Connectors must be greased with Molykote 44 Medium before every mating
- A layer of grease corresponding to minimum 1/10 of socket depth should be applied to the female connector
- The inner edge of all sockets should be completely covered, and a thin transparent layer of grease left visible on the face of the connector
- After greasing, fully mate the male and female connector in order to secure optimal distribution of grease on pins and in sockets
- To confirm that grease has been sufficiently applied, de-mate and check for grease on every male pin. Then re-mate the connector

### Greasing and mating under water (wet mate)

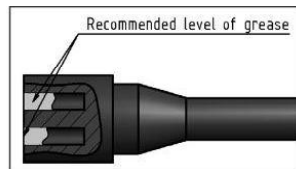

- Connectors must be greased with Molykote 44 Medium before every mating
- A layer of grease corresponding to approximately 1/3 of socket depth should be applied to the female connector
- All sockets should be completely sealed, and transparent layer of grease left visible on the face of the connector
- After greasing, fully mate the male and female connector and remove any excess grease from the connector joint

### Cleaning

- General cleaning and removal of any accumulated sand or mud on a connector should be performed using spray based contact cleaner (isopropyl alcohol)
- New grease must be applied again prior to mating