



Operating and Assembly Instructions

Basic device UOM 4L-1212 / UOMH 4L-1212

in construction type B5 (flange), B35 (flange and foot) and hollow shaft design

**Read the operating and assembly instructions prior to assembly, starting installation and handling!
Keep for future reference!**



Trademark

U-ONE® is a registered trademark of Johannes Hubner Fabrik elektrischer Maschinen GmbH.

Windows® is a registered trademark of Microsoft Corporation in the United States and other countries.

Viton® is a registered trademark by Du Pont.

Loctite® is a registered trademark from Henkel AG & Co. KGaA, Düsseldorf.

All other brand names and product names are trademarks or registered trademarks of their respective owner.

Protected trademarks bearing a ™ or ® symbol are not always depicted as such in the manual.

However, the statutory rights of the respective owners remain unaffected.

Manufacturer / publisher

Johannes Hubner

Fabrik elektrischer Maschinen GmbH

Siemensstraße 7

35394 Giessen

Germany

Phone: +49 641 7969-0

Fax: +49 641 73645

E-Mail: info@huebner-giessen.com

www.huebner-giessen.com

Headquarters: Giessen

Court of registration: Giessen

Commercial register number: HRB 126

The manual has been drawn up with the utmost care and attention. Nevertheless, we cannot exclude the possibility of errors in form and content. It is strictly forbidden to reproduce this publication or parts of this publication in any form or by any means without the prior written permission of Johannes Hubner Fabrik elektrischer Maschinen GmbH.

Subject to errors and changes due to technical improvements.

Copyright © Johannes Hubner Fabrik elektrischer Maschinen GmbH.

All rights reserved.

Directory

1	General	5
1.1	Information about the operating and assembly instructions	5
1.2	Scope of supply - basic device	5
1.3	Explanation of symbols	5
1.4	Disclaimer	6
1.5	Copyright.....	6
1.6	Guarantee terms.....	6
1.7	Customer service.....	6
2	Safety.....	6
2.1	Responsibility of the owner.....	6
2.2	Personnel.....	7
2.3	Personal protective equipment	7
2.4	Special dangers	8
2.4.1	Electrical current.....	8
2.4.2	Rotating shafts / Hot surfaces	8
2.4.3	Safeguarding against restart	8
3	Technical Data	9
3.1	Type plate	9
3.2	Type key	9
3.3	Electrical and mechanical data	10
3.3.1	Connected loads, environment.....	10
3.3.2	Mechanical Data.....	10
3.3.3	Degree of protection	11
3.3.4	Dimension drawings	12
4	Installation and commissioning UOM(H) 4L-1212	20
4.1	Safety instructions	20
4.2	Technical information.....	20
4.3	Required tools.....	21
4.4	Mounting preparations	21
4.5	Mounting B5 type (flange).....	21
4.6	Mounting B35 type (flange and foot)	23
4.7	Mounting tolerances for Construction Type B5 and B35	24
4.8	Attaching additional devices	25
4.9	Mounting hollow-shaft type	26
4.10	Dismantling	27
4.10.1	Safety instruction	27
4.10.2	Dismantling the universal encoder type B5 and B35.....	27
4.10.3	Dismantling hollow shaft type	27
4.11	Electrical / fiber optic connection and commissioning	27
4.11.1	Electrical / fiber optic connection	28
4.12	Intended use	29
4.13	Improper use.....	29
4.14	Inspections.....	29

4.14.1	Safety advice for personnel	29
4.14.2	Maintenance information	29
4.14.3	Inspection schedule	30
4.15	Fault table	30
5	Replacement parts	31
6	Transport, packaging and storage	32
6.1	Safety information concerning transport	32
6.2	Goods inward inspection	32
6.3	Packaging (disposal)	32
6.4	Storing packages (devices)	32
6.5	Returning devices (repairs/goodwill/warranty).....	32
6.6	Disposal	32
7	EC-Declaration of Incorporation	33

1 General

1.1 Information about the operating and assembly instructions

These operating and assembly instructions provide important instructions for working with the device. They must be carefully read prior to starting all tasks, and the instructions contained herein must be followed.

In addition, applicable local regulations for the prevention of industrial accidents and general safety regulations must be complied with.

For other, non SIL certified electronic function modules please refer to the separate Operating and Installation Instructions.

1.2 Scope of supply - basic device

The scope of supply for the basic device includes the universal encoders UOM 4L-1212 or UOMH 4L-1212, the fastening screws as well as the Operating and Assembly Instructions.

The exact scope of supply is listed in the order confirmation.

1.3 Explanation of symbols

Warnings are indicated by symbols in these operating and assembly instructions. The warnings are introduced by signal words that express the scope of the hazard.

The warnings must be strictly heeded; you must act prudently to prevent accidents, personal injury, and property damage.



WARNING!

Indicates a possibly dangerous situation that can result in death or serious injury if it is not avoided.



CAUTION!

Indicates a possibly dangerous situation that can result in minor injury if it is not avoided.



CAUTION!

Indicates a possibly dangerous situation that can result in material damage if it is not avoided.



NOTES!

Indicates useful tips and recommendations as well as information for efficient and trouble-free operation.



NOTES!

Do not use a hammer or similar tool when installing the device due to the risk of damage occurring to the bearings or coupling!



DANGER!

Life-threatening danger due to electric shock!

Indicates a life-threatening situation due to electric shock. If the safety instructions are not complied with there is danger of serious injury or death. The work that must be executed should only be performed by a qualified electrician.

1.4 Disclaimer

All information and instructions in these (assembly) instructions have been provided under due consideration of applicable guidelines, as well as our many years of experience.

The manufacturer assumes no liability for damages due to:

- Failure to follow the instructions in the (assembly) instructions
- Non-intended use
- Deployment of untrained personnel
- Opening of the device or conversions of the device

In all other aspects the obligations agreed in the delivery contract as well as the delivery conditions of the manufacturer apply.

1.5 Copyright



NOTES!

Content information, text, drawings, graphics, and other representations are protected by copyright and are subject to commercial property rights.

It is strictly forbidden to make copies of any kind or by any means for any purpose other than in conjunction with using the device without the prior written agreement of the manufacturer. Any copyright infringements will be prosecuted.

1.6 Guarantee terms

The guarantee terms are provided in the manufacturer's terms and conditions.

1.7 Customer service

For technical information personnel is available that can be reached per telephone, fax or email. See manufacturer's address on page 2.

2 Safety



DANGER!

This section provides an overview of all the important safety aspects that ensure protection of personnel, as well as safe and trouble-free device operation.

If these safety instructions are not complied with significant hazard can occur.

2.1 Responsibility of the owner

The device is used in commercial applications. Consequently the owner of the device is subject to the legal occupational safety obligations, and subject to the safety, accident prevention, and environmental protection regulations that are applicable for the devices area of implementation.

2.2 Personnel

Qualified personnel only are permitted to install, mount, program, commission, operate, maintain and take out of service the devices.

2.3 Personal protective equipment

Wear personal protective equipment such as safety shoes and safety clothing to minimise risks to health and safety when carrying out work such as installation, disassembly or commissioning. Adhere to all applicable statutory regulations as well as the rules and standards determined by the owner.

2.4 Special dangers

Residual risks that have been determined based on a risk analysis are cited below.

2.4.1 Electrical current



DANGER!

Life-threatening danger due to electrical shock!

There is an imminent life-threatening hazard if live parts are touched. Damage to insulation or to specific components can pose a life-threatening hazard.

Therefore:

Immediately switch off the device and have it repaired if there is damage to the insulation of the power supply.

De-energize the electrical equipment and ensure that all components are connected for all tasks on the electrical equipment.

Keep moisture away from live parts. Moisture can cause short circuits.

2.4.2 Rotating shafts / Hot surfaces



WARNING!

Danger of injury due to rotating shafts and hot surfaces!

Touching rotating shafts can cause serious injuries.

Therefore:

Do not reach into moving parts/shafts or handle moving parts/shafts during operation. Close to protect from injury all access openings in flanges with the corresponding plug screw, and provided you exposed rotating components with protective covers.

Do not open covers during operation. Prior to opening the covers ensure that all parts have come to a standstill.

The encoder can become hot during prolonged use.

In case of contact risk of burns is existing.

2.4.3 Safeguarding against restart



DANGER!

Life-threatening danger if restarted without authorization!

When correcting faults there is danger of the power supply being switched on without authorization.

This poses a life-threatening hazard for persons in the danger zone.

Therefore:

Prior to starting work, switch off the system and safeguard it from being switched on again.

3 Technical Data

3.1 Type plate



The type plate is located on the side of the housing and contains the following information:

- Manufacturer, address
- CE-mark
- Type, year of construction (Bj/Y)
- Serial number (S/N)
- Commission number (C/N)
- Max. speed
- Supply voltage
- Switching voltage / max. switching current
- Certification
- Resolution

3.2 Type key

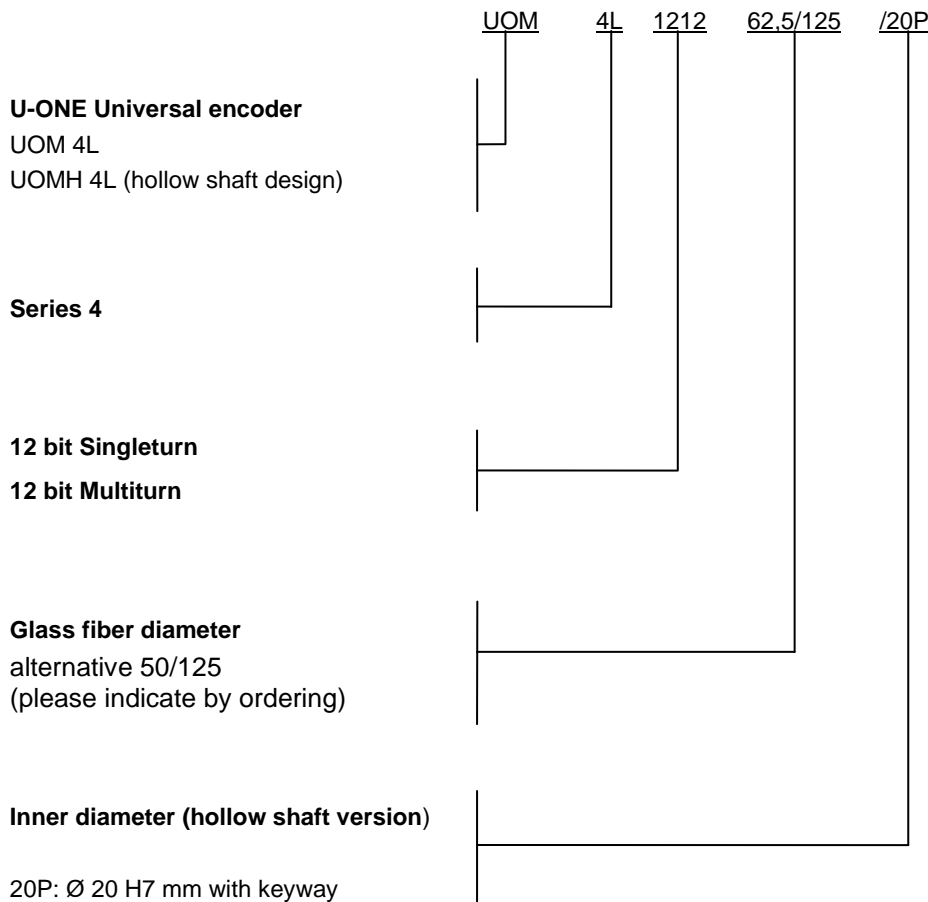

3.3 Electrical and mechanical data

3.3.1 Connected loads, environment

Basic device UOM(H) 4L-1212	Electrical Data	Worth
	Supply voltage	12 to 30 V DC
	Power consumption	max. 2 W
	Resolution incremental	1024 symmetrical square wave pulses
	Absolut Singleturn	12 Bit (4096 steps per Revolution)
	Absolut Multiturn	12 Bit (4096 Revolutions)
	Signal transmission	by means of fiber optic cable for cable 50/125µm or 62,5/125µm
	Connection diagram see page 28	EL 667 b
	Device temperature range	-25 to +85°C

Basic device UOM 4L-1212:	Mechanical Data	Worth
	Shaft end	11j6x30 mm (Standard) 14j6x30 mm (optional)
	Degree of protection	IP 55 or IP 66 according EN 60529
	max. permissible speed	3000 rpm
	Electrically and fiber optic connection	Terminal box COMBICON terminal strip 2 x ST-plug connection for fiber optics cable 50/125 µm or 62,5/125 µm
Basic device UOMH 4L-1212	Inner diameter	20 H7 with keyway

3.3.2 Mechanical Data

Description		Worth	
UOM 4L-1212	Max. encoder shaft load	F _{a max.} (axial) = 100 N F _{r max.} (radial) = 120 N	
	Shaft end	11j6 x 30 mm (standard) 14j6 x 30 mm (optional)	
	Weight	UOM 4L-1212 with one shaft end with two shaft ends	Approx. 3,4 kg Approx. 4,3 kg
UOMH 4L-1212	Weight	UOMH 4L-1212	Approx. 4,1 kg

3.3.3 Degree of protection

Degree of protection acc.to DIN EN 60529	Sealing	Permissible speed	Rotor moment of inertia (1 shaft end)	Breakaway torque	
UOM 4L-1212	IP 55	Standard	≤ 3000 rpm	Approx. 975 gcm ²	Approx. 8 Ncm
	IP 66	with axial shaft seal	≤ 3000 rpm	Approx. 975 gcm ²	Approx. 10 Ncm
	IP 66	with radial shaft seal (for special applications, e.g. wet areas in rolling mills)	≤ 3000 rpm	Approx. 975 gcm ²	Approx. 11 Ncm
UOMH 4L-1212	IP 55	Standard	≤ 3000 rpm	Approx 2440 gcm ²	Approx.15 Ncm
	IP 66	with axial shaft seal	≤ 3000 rpm	Approx. 2440 gcm ²	Approx.30 Ncm
	IP 66	with radial shaft seal (for special applications, e.g. wet areas in rolling mills)	≤ 3000 rpm	Approx. 2440 gcm ²	Approx.35 Ncm
Vibration resistance	DIN IEC 68-2-29 (50...2000 Hz)		20g		
Shock resistance	DIN IEC 68-2-29		100g		

Addition –i:

Special color treatment
FKM seals



NOTES!

Thermal factors influencing the permissible maximum speed of the UOM(H) 4 L are determined by the place of installation. The maximum ambient temperature of the place of installation should not exceed 70°C ...75 °C (85 °C version).

It is possible to determine the maximum permissible ambient temperature for the UOMH 4 as follows:

$$n_{therm,zul.} = \frac{85 \text{ °C} - T_{umg}}{9 \cdot 10^{-3} \frac{K}{1/min}}$$

T_{umg} .: Temperature of the relevant attachment point

Verification measurements may be required in some individual cases.

3.3.4 Dimension drawings

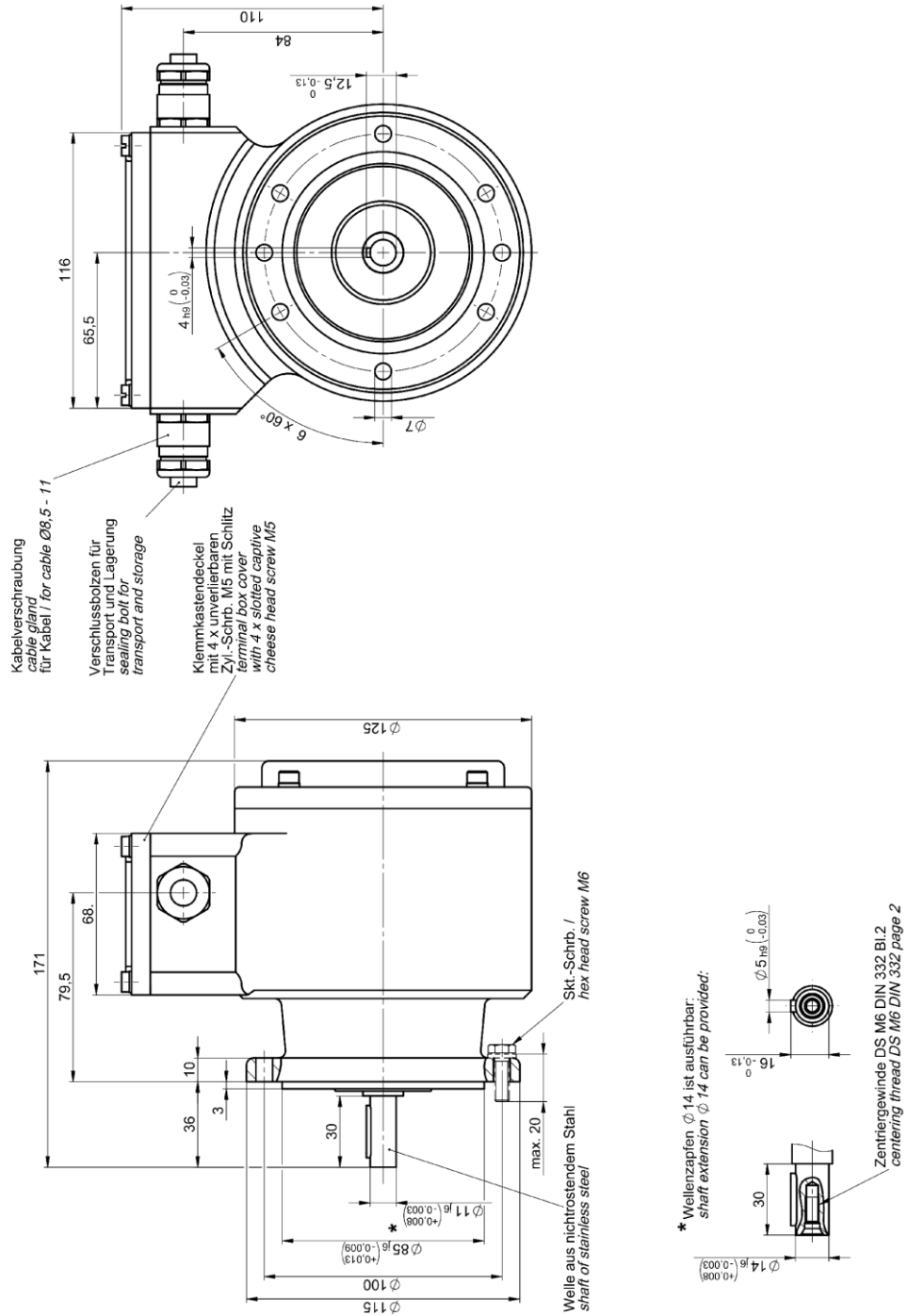

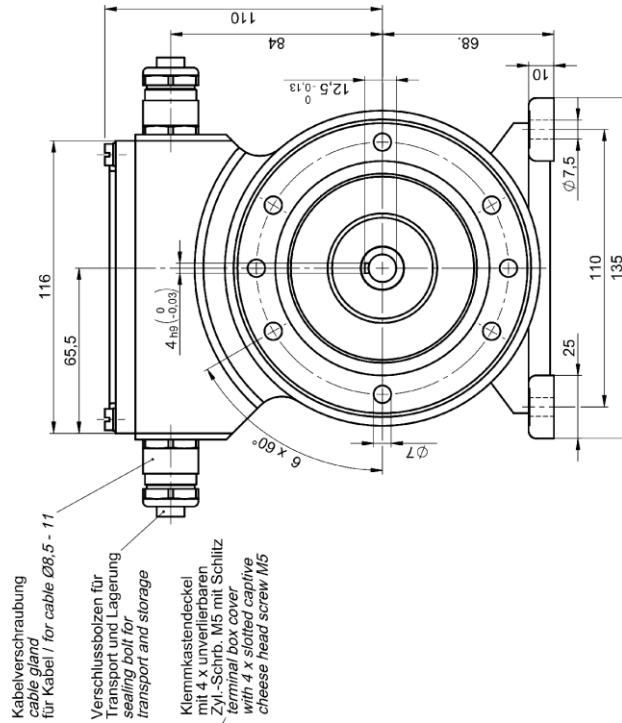

Für genauen Anbau, Distanzplättchen verwenden.
Form passend für Fußbauform nach Zchn. E-54824
mit unterschiedlichen Justierhöhen.
Lieferbare Dicken: 0.1 / 0.2 / 0.5 / 1.0 / 2.0 mm (paarig)
For precise adjustment please use our matching plates
Shape matching to foot construction as per drwg. E-54824
with different adjustment heights available heights
0.1 / 0.2 / 0.5 / 1.0 / 2.0 mm (pairs)

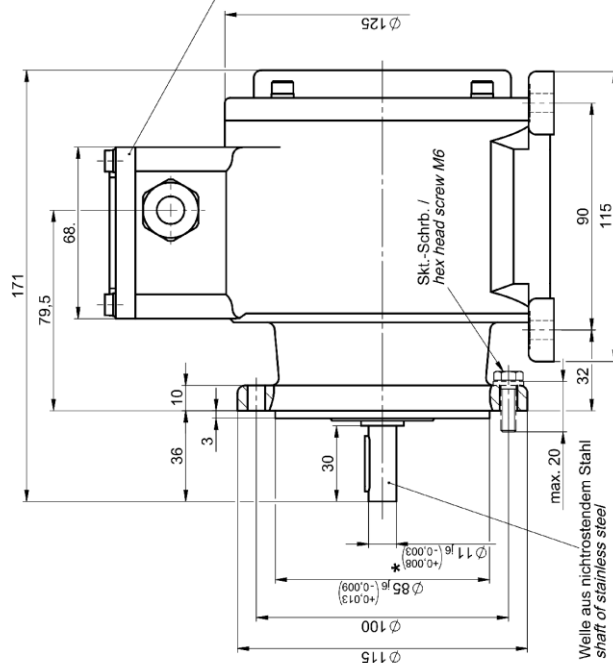

* Wellenzapfen Ø14, ist ausführbar.
shaft extension Ø 14 can be provided:

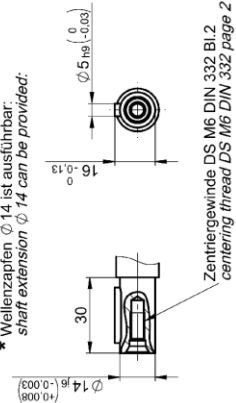

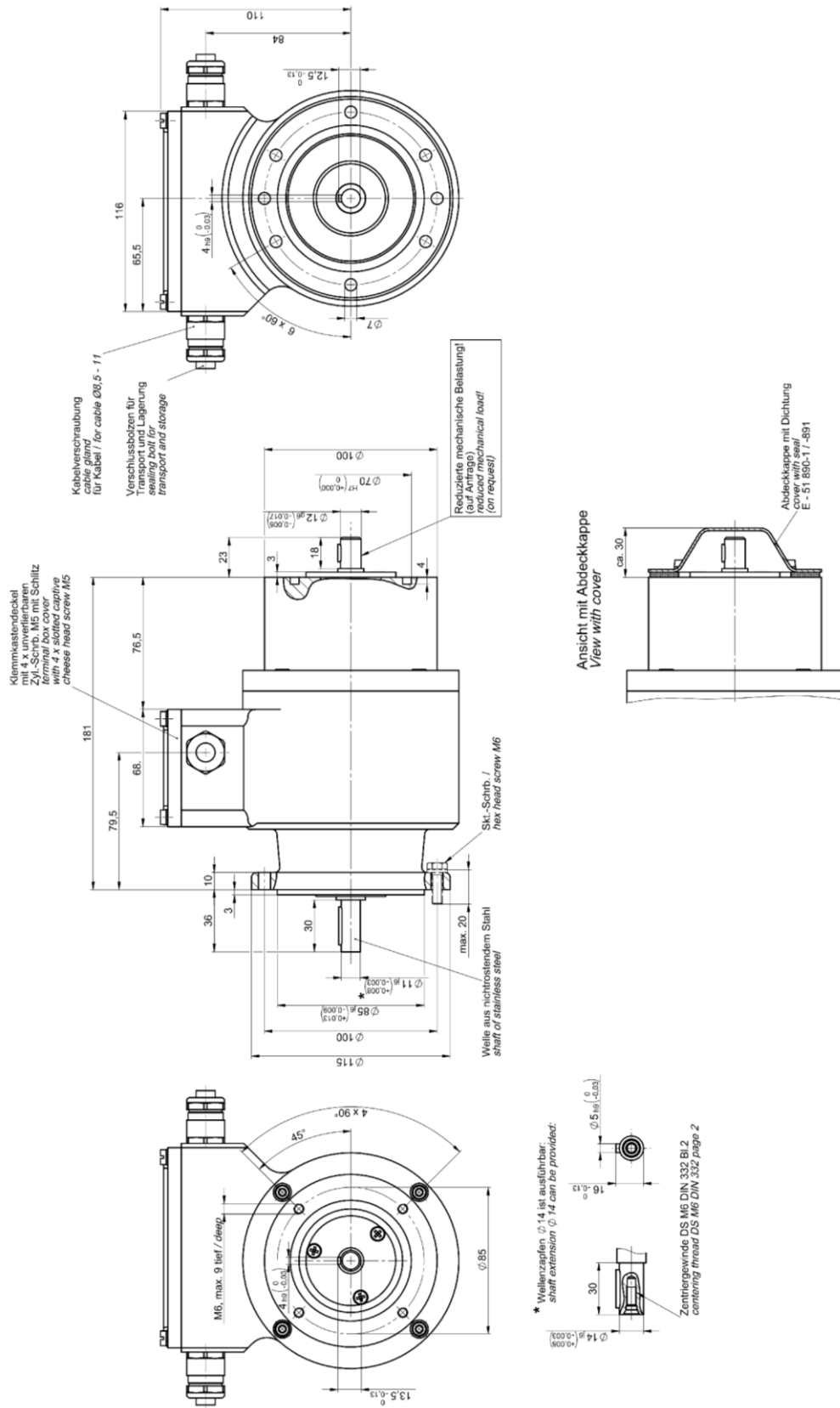

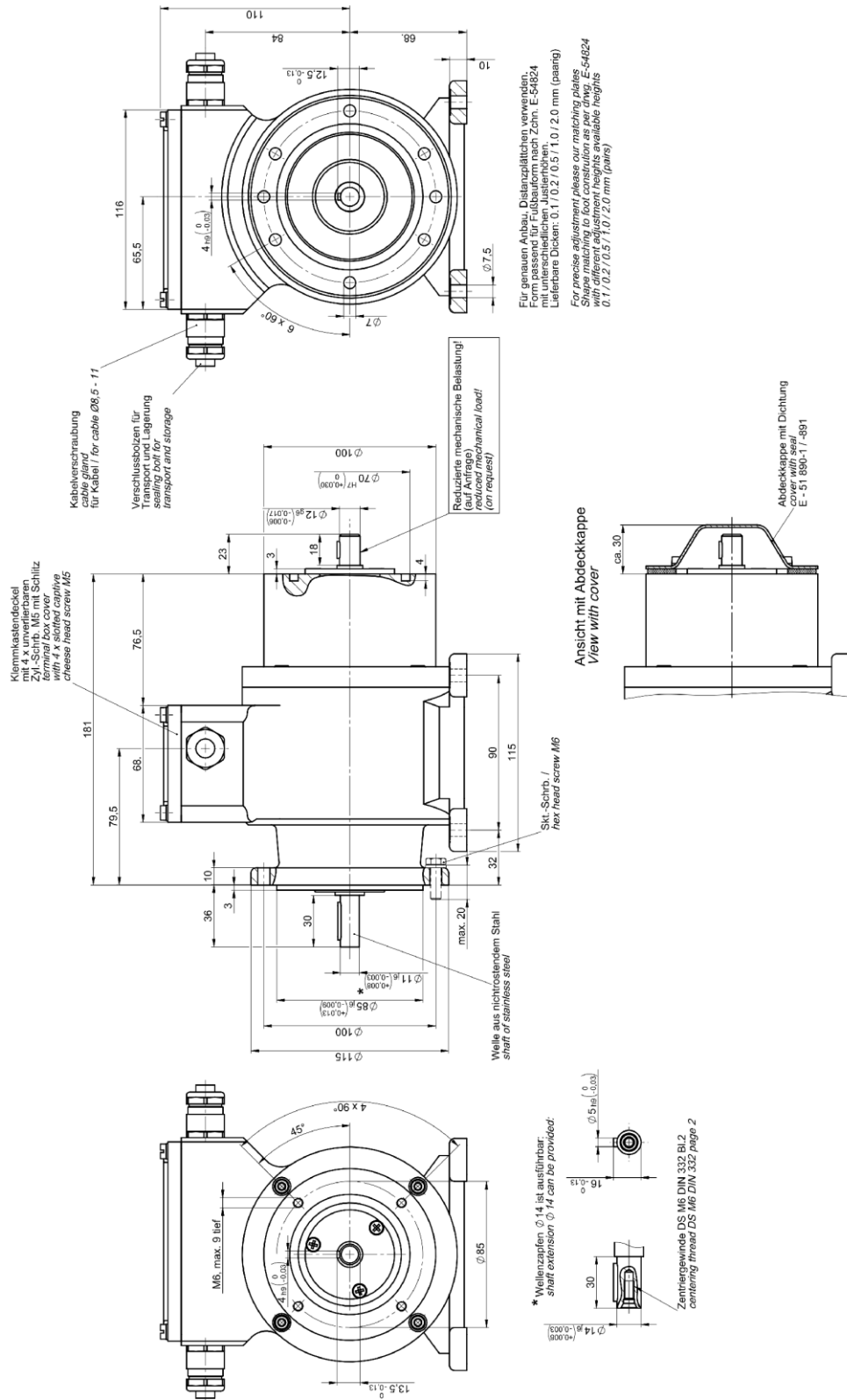

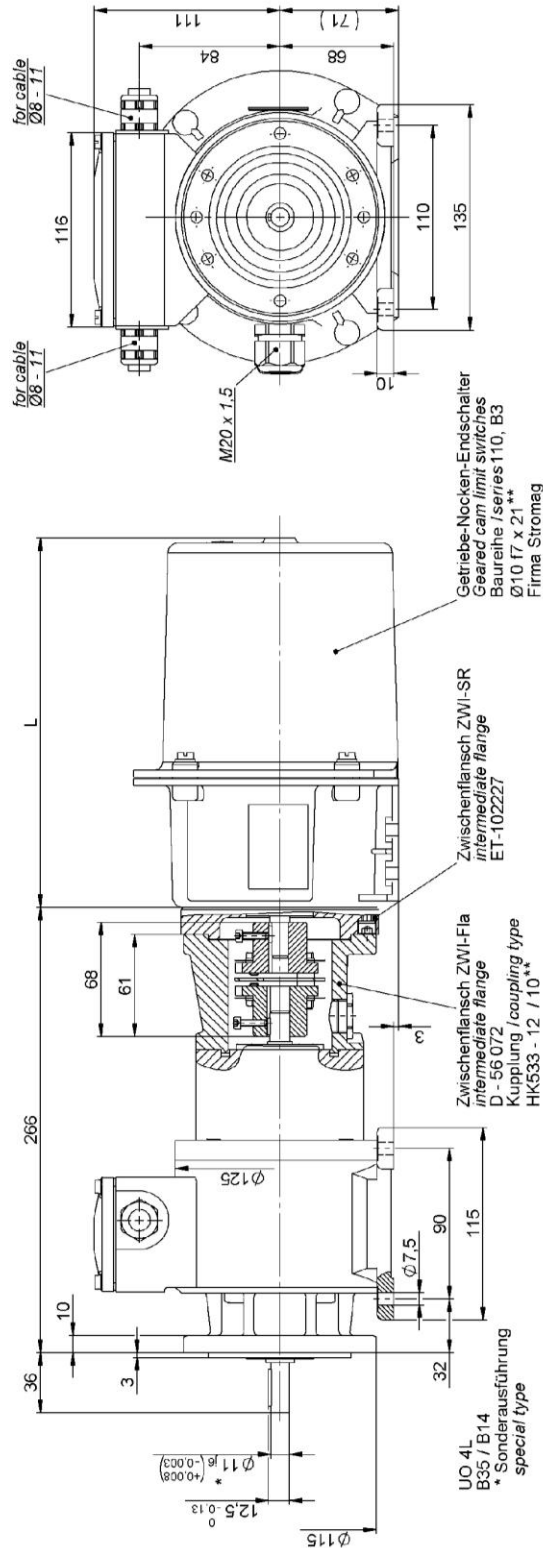

**** Sonderpassfeder 4 breit
special feather key**

Für genauen Anbau Distanzplättchen verwenden.
Form passend zur Fußbauform nach Zchn. E-54824
mit unterschiedlichen Justierhöhen lieferbare Dicken.

For precise adjustment please use our matching plates.
Shape matching to foot construction as per drwg. E-54824
with different adjustment heights available heights
0,1/0,2/0,5/1,0/2,0 mm (pairs)

C	281
B	221
A	156
Getriebegröße / Geared size	L

Änderungen vorbehalten
modifications reserved

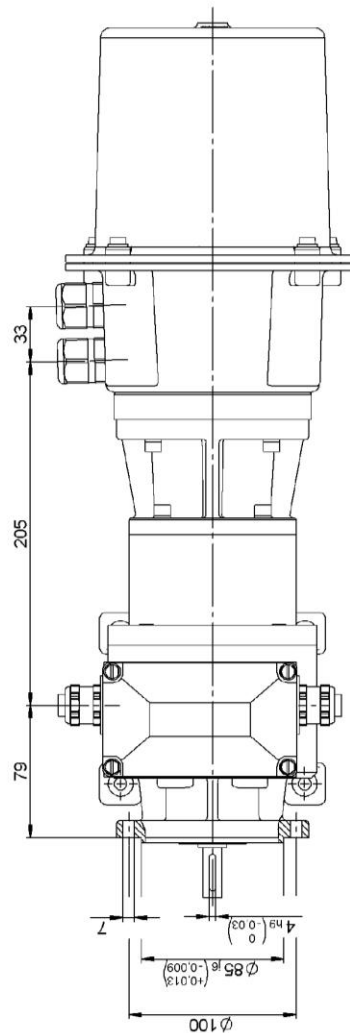

* AS-Wellenzapfen $\varnothing 14j6$ ist ausführbar
DE shaft $\varnothing 14j6$ can be provided

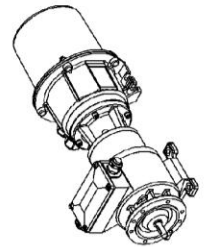
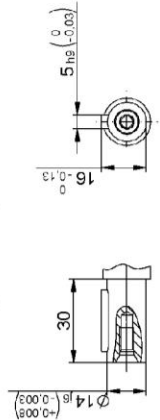

U-ONE®

Construction type B35/B14
with geared cam limit switch

HM 11 M 104513

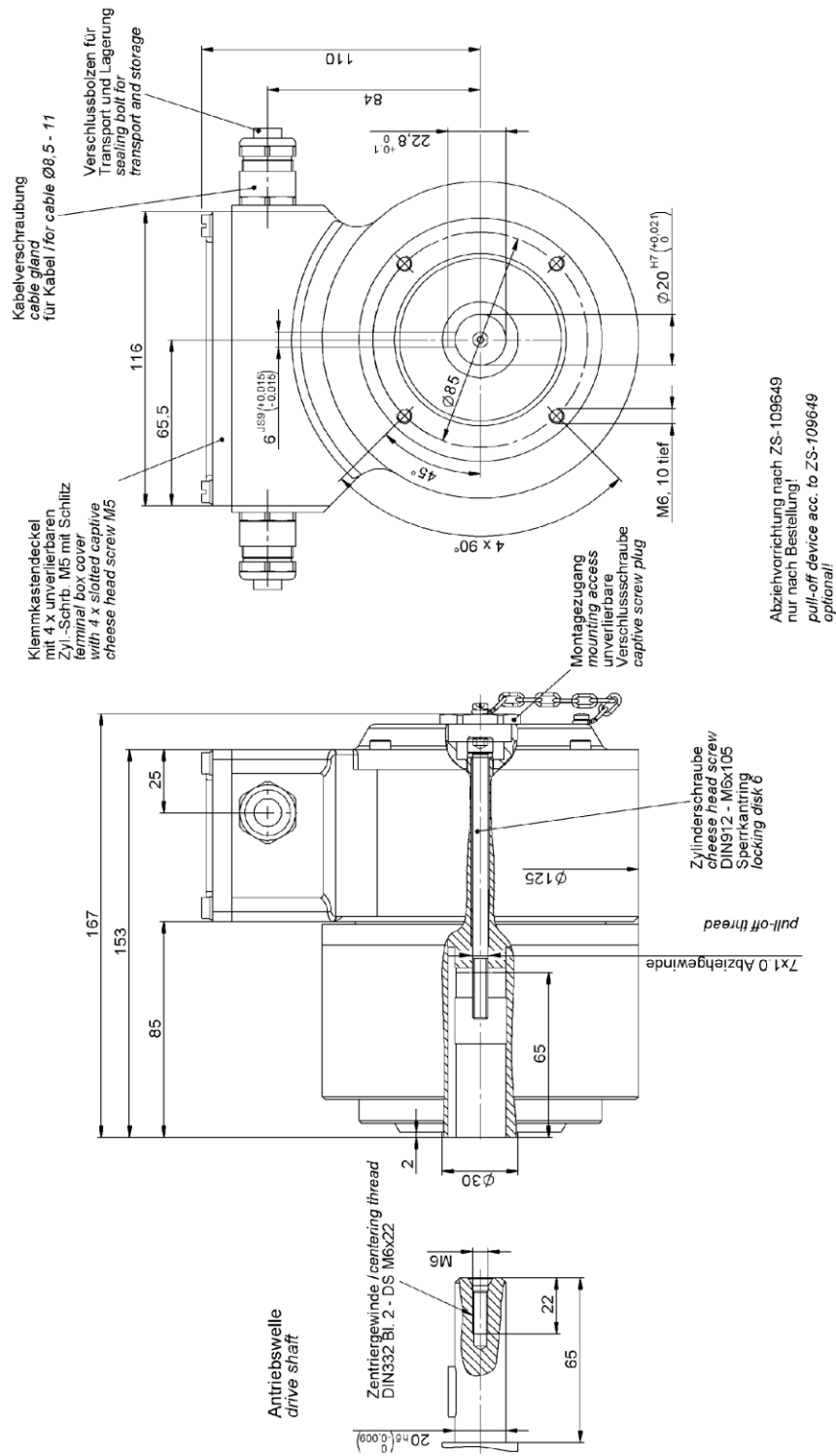

U-ONE®

Construction type
hollow shaft with drive shaft

HM 16 M 109945

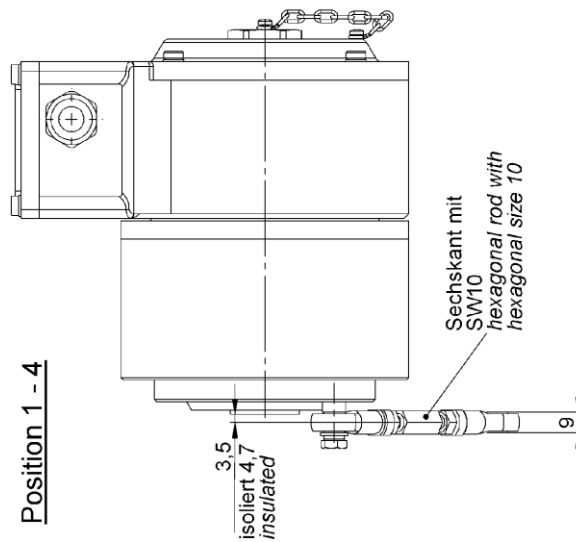
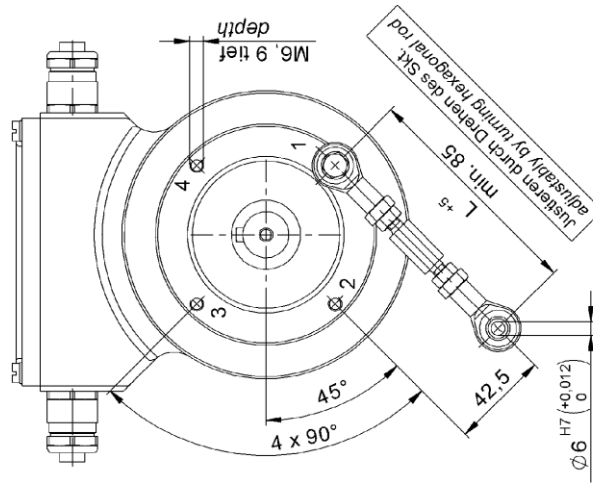

Abziehvorrichtung nach ZS-109649
nur nach Bestellung!
pull-off device acc. to ZS-109649
optional!

Länge / Length L	100; 125; 150; 200
andere Längen auf Anfrage / other lengths on request	

U-ONE®

Construction type
hollow shaft with torque bracket

HM 16 M 109951

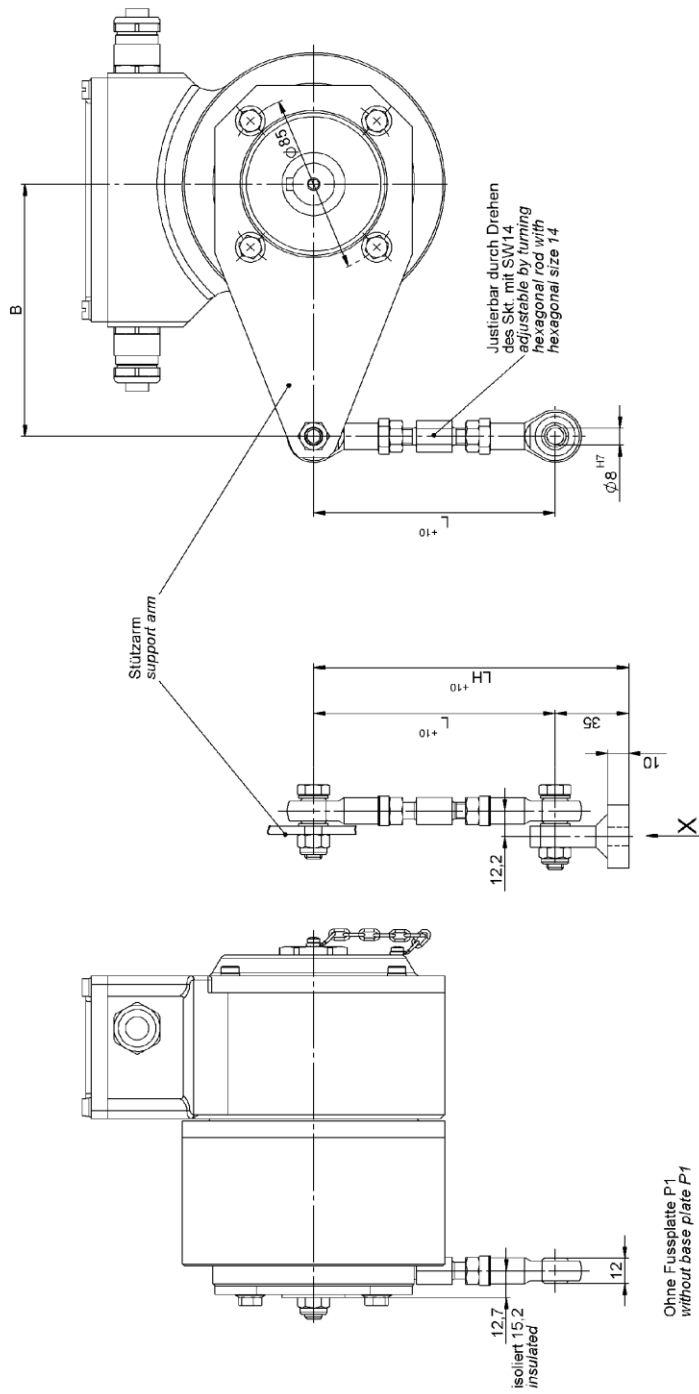

Länge / length L	125, 150, 200, 300, 500
Länge / length B	120, 150, 250, 500
andere Längen auf Anfrage / other lengths on request	
Länge mit Fussplatte LH = L + 35 / length with base plate LH = L + 35	
Bei Bestellung B / L bzw. LH angeben! / indicate B / L or LH!	

Mit Fussplatte P1
with base plate P1
E-54368

Ansicht "X"

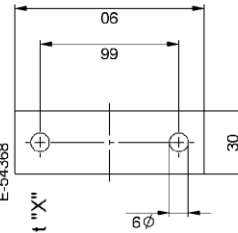

Ohne Fussplatte P1
without base plate P1

Abziehvorrichtung nach ZS-109649
nur nach Bestellung!
pull-off device acc. to ZS-109649
optional!

U-ONE®

Construction type
hollow shaft with torque bracket

HM 16 M 109946

4 Installation and commissioning UOM(H) 4L-1212

4.1 Safety instructions



NOTES!

Observe the safety instructions contained in **Chapter 2** when installing or working on the device!

In conjunction with the electronic function modules UO-EM-D2 and UO-EM-EGS4 the universal U-ONE® 4 series encoder system is a switching device designed to ensure the safety of machines, devices and systems in line with application requirements.

Inspection

Observe and adhere to all relevant regulations, guidelines and laws when utilising the UO-EM-EGS4 to monitor overspeeds in machines and systems. Inspect the device on a regular basis. Inspections must be recorded in a log book (see Inspection schedule chapter 4.14.3).

Furthermore, we remind you of your obligation to adhere to the various relevant country-specific laws, guidelines and standards. You must also observe the supplied operating and installation instructions that in addition to specifying safety and commissioning procedures for the device, individual components and the entire system also define regular inspection schedules (electrical and mechanical functional testing).

Personnel

Installation and commissioning must be carried out by qualified personnel only. (See chapter 2.2).

4.2 Technical information



NOTES!

Do not use a hammer or similar tool when installing the device due to the risk of damage occurring to the bearings or coupling!

Ambient temperature

The max. permissible ambient temperature depends on the speed and degree of protection of the device, the signal frequency, the length of the signal cable and the place of installation (please refer to Chapter 3.3).

Degree of protection

To fulfill degree of protection requirements the diameter of the connection cable must correspond to that of the cable gland (please refer to Chapter 3.3.4 dimension drawings)

Deep groove ball bearings

The universal encoder from the series U-ONE 4 is fitted with maintenance-free, lifetime lubricated deep groove ball bearings.

Bearings must be changed by the manufacturer only. Opening the device renders the guarantee null and void.

Screw retention

We recommend applying Loctite® 243 (medium strength threadlocker) to all fastening screws to prevent them becoming loose.

4.3 Required tools

- Spanners: 10 mm, 13 mm, 22 mm, 24 mm
- Allen keys: 2 mm, 3 mm, 5 mm
- Flat-blade screwdrivers:
- Assembly grease (acid-free)
- Loctite® 243 (medium strength threadlocker)

4.4 Mounting preparations

1. Ensure all accessories are available (please refer to Chapter 3.3.4 dimension drawings).
2. Preparing the place of attachment: Clean the (motor) shaft, centering, bolting surfaces and fastening threads; check for damage. Repair any damage!

4.5 Mounting B5 type (flange)

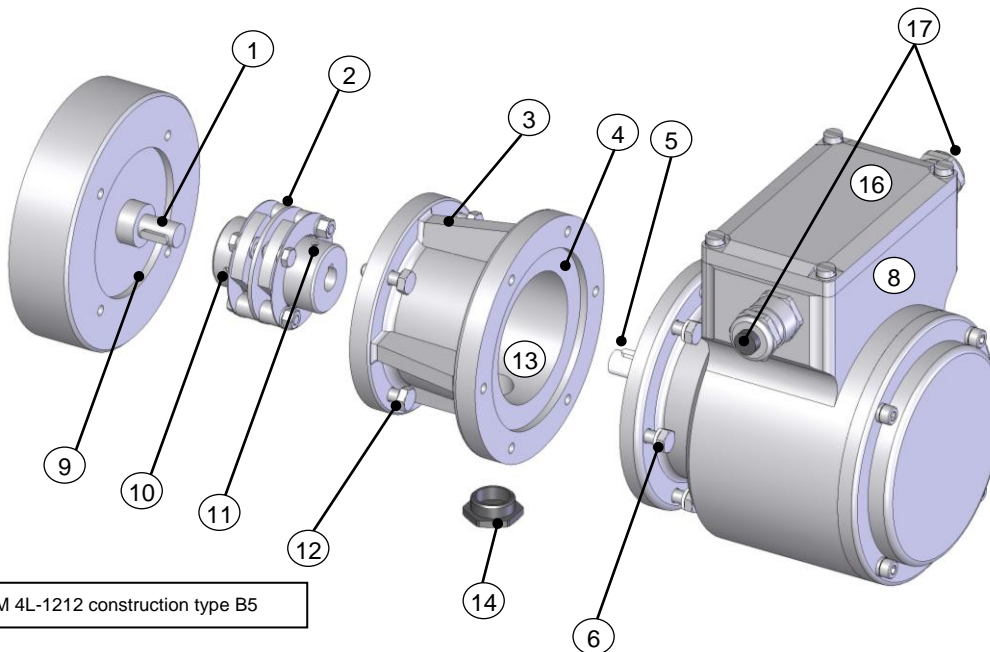

Fig.1: UOM 4L-1212 construction type B5

1. Lightly grease the (motor) shaft (1) and centering (9).
2. Fit coupling (2) onto (motor) shaft.



NOTES!

You must be able to mount the coupling without force. Ream out the bores of used couplings, if necessary! We recommend our zero-backlash, torsion-resistant HK 5 coupling to attach the UOM 4 L-1212. Please refer to the catalogue Torsion Resistant Couplings for encoders.

3. Secure the coupling hub on the (motor) shaft with a grub screw or cheese head screw (10) (depending on the coupling type).

4. Fasten the intermediate flange (3) to the motor using the fastening screws (12).



NOTES!

If possible, fit the intermediate flange in a manner that ensures the screwed sealing plug (14) points downwards!

5. Lightly grease the universal encoder shaft (5) and centering (4).

6. Fit the universal encoder UOM 4L-1212 (8) into both the centering (4) and coupling hub at the same time.



NOTES!

You must be able to mount the coupling without force. Ream out the bores of used couplings, if necessary!

7. Secure the universal encoder UOM 4L-1212 with 4 - 6 screws (6) evenly distributed around the circumference of the flange.

8. Remove the sealing plug (14) from the access bore (13) to the coupling.

9. Secure the coupling hub on the universal encoder shaft with a grub screw or cheese head screw (11) (depending on the coupling type).



NOTES!

To carry out this task, it may be necessary to turn the (motor) shaft to the correct position.

10. Replace the sealing plug to seal the access bore to the coupling with a plug screw (14).

4.6 Mounting B35 type (flange and foot)



NOTES!

B35 type encoders can be attached by means of a flange (B5, please refer to Chapter 4.5) or foot (B3):

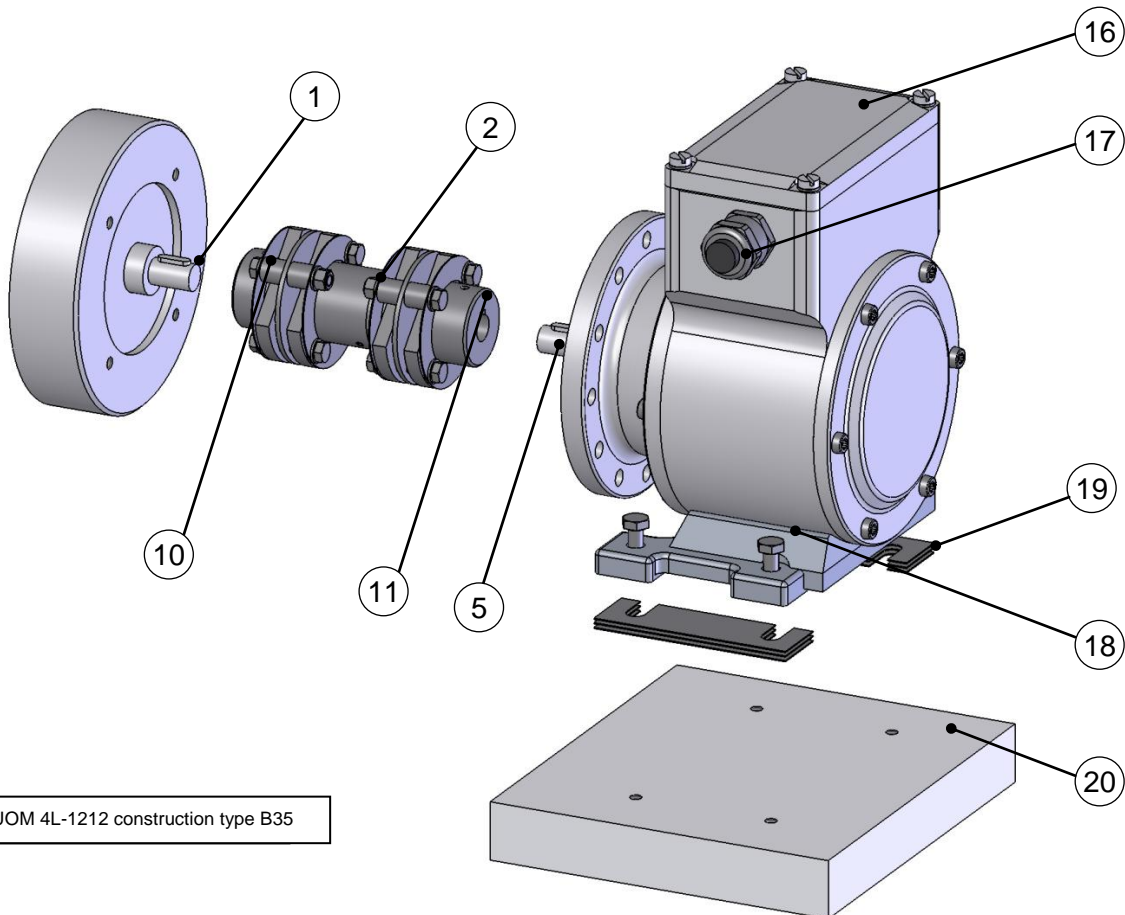

Fig.2: UOM 4L-1212 construction type B35

1. Lightly grease the (motor) shaft (1).
2. Fit coupling (2) onto (motor) shaft.



NOTES!

You must be able to mount the coupling without force. Ream out the bores of used couplings, if necessary!



NOTES!

We recommend our zero-backlash, torsion-resistant **double-joint coupling HKD5** to attach B35 type encoders. Please refer to the catalogue *Torsion Resistant Couplings for Encoders*.

3. Secure the coupling hub on the (motor) shaft with a grub screw or cheese head screw (10) (depending on the coupling type).

4. Align the universal encoder shaft (5) to the (motor) shaft and insert into the coupling hub.



NOTES!

Use shims (19) to achieve the correct vertical alignment to the base plate (20).

Observe information in Chapter 4.7 about mounting errors and max. permissible mounting tolerances!

5. Fasten universal encoder foot with 4 M6 hexagon head screws (18).

6. Secure the coupling hub on the universal encoder shaft with the grub screw or cheese head screw (11) (depending on the coupling type).



NOTES!

To avoid injuries by turning parts, the coupling must be provided before introduction with a suitable cover.

4.7 Mounting tolerances for Construction Type B5 and B35



NOTES!

Angle misalignment and parallel displacement between the (motor) shaft and the encoder shaft are mounting errors and should be kept as small as possible.

Mounting errors

- Cause radial forces to act on the encoder shaft.
- Reduce the service life of the bearings and the coupling.
- Degrade the quality of the signals (harmonic content).

Mounting tolerances for our zero-backlash, torsion-resistant couplings HK5 and HKD5:

Coupling	Axial offset a	Angular error α	Parallel offset e
HK 5	$\pm 1 \text{ mm}$	0.5°	-
HKD 5	$\pm 1.5 \text{ mm}$	0.5°	0.5 mm

4.8 Attaching additional devices



NOTES!

The universal encoder (1) in B5/B14 or B35/B14 has a second shaft extension and a B14 type flange on the non-drive end, onto which it is possible to fit an additional device with a B5 flange via an intermediate flange (2), for example an incremental encoder, absolute encoder, cam limit switch (3) or an overspeed switch. This design option makes it possible to combine up to two devices.

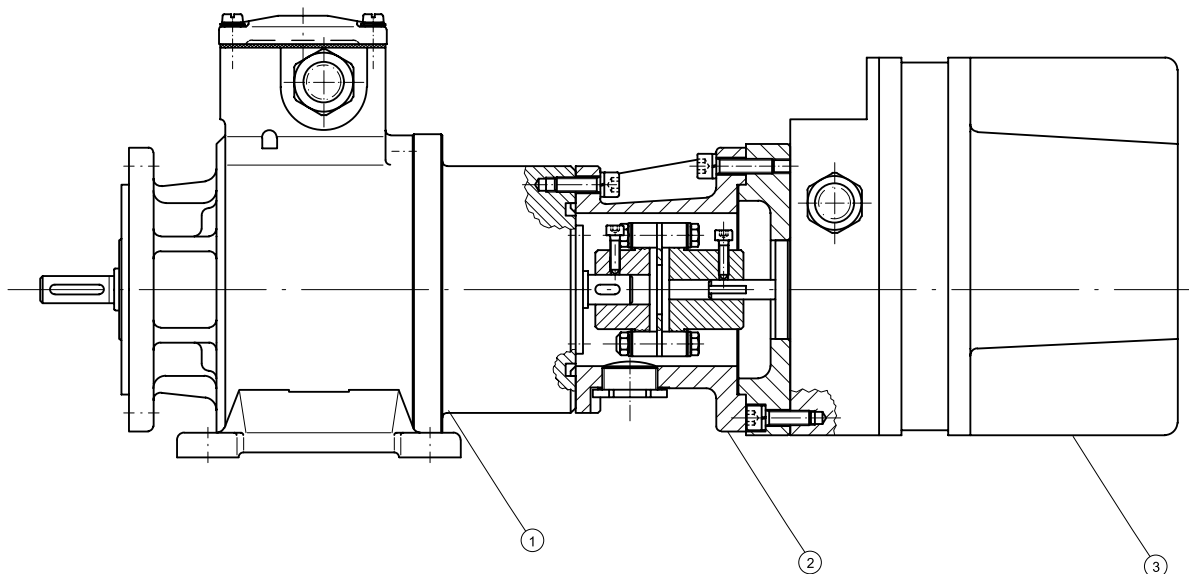

Fig.3: UOM 4L-1212 construction type B35 with coupled geared cam limit switch

When supplied ex works the second shaft end is protected by a cover plate

2. Remove the cover plate.



NOTES!

Ensure no liquids or dirt are allowed ingress into the device when the cover plate is removed.



WARNING!

If no second device is added ensure the cover plate is fitted to protect and cover the second shaft end. This prevents the risk of injury and maintains the protection class rating of the device. Replace the cover plate if there is any delay when fitting a second device.

4.9 Mounting hollow-shaft type

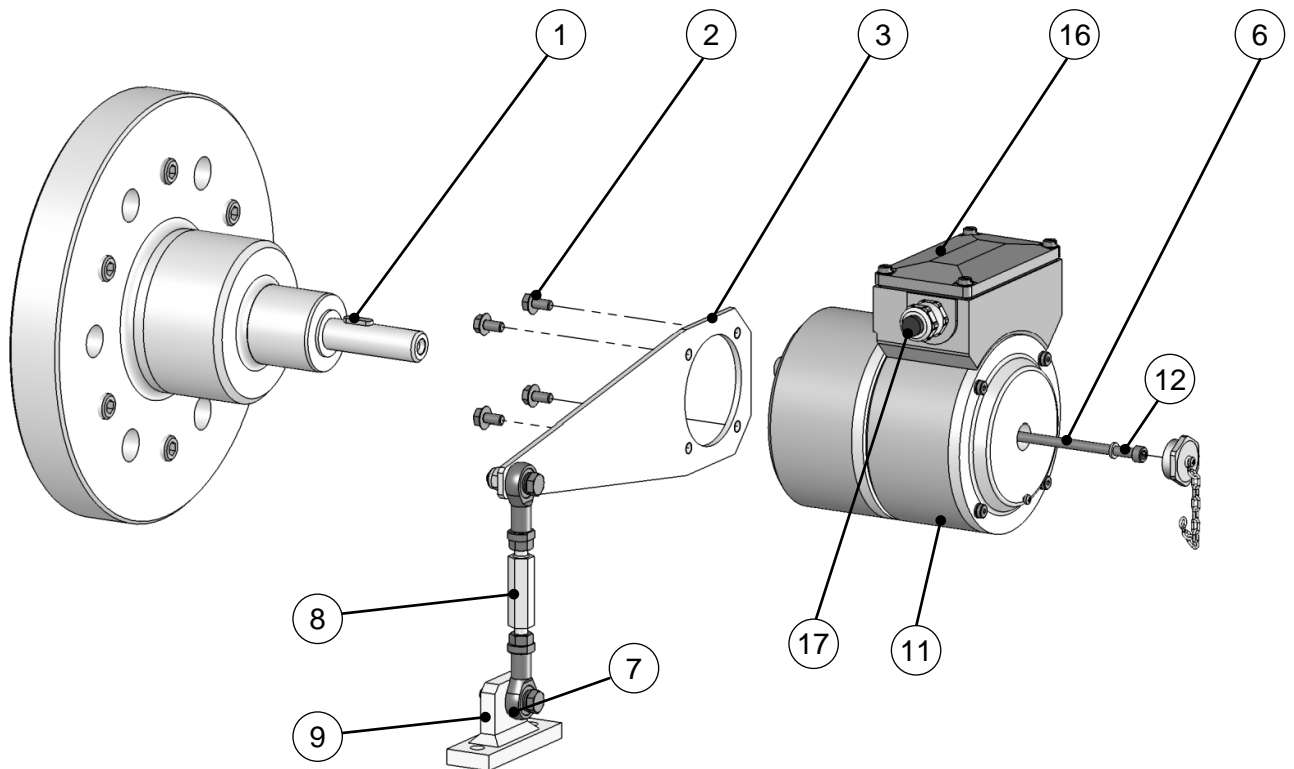

1. Mount adapter shaft (1) and align using dial gauge.



NOTES!

The maximum radial run-out of the adapter shaft is 0.05 mm.
If necessary, use the ball thrust adjustment screw to align the adapter shaft. Secure ball thrust screws with Loctite® 243. Remove unused ball thrust screws or secure with Loctite® 243. Max. tightening torque for M12 approx. 25 Nm, for M16 approx. 35 Nm. Use parallel keys to DIN 6885.
Please also observe the supplement data sheet *Mounting accuracy for hollow shaft encoders*.
You should also observe the Installation instructions supplied with the adapter shaft when installing!

2. Lightly grease the adapter shaft.
3. Secure the torque bracket (3) to the hollow-shaft device (11) with 4 tensilock screws (2).
4. Mount the hollow-shaft device to the adapter shaft.



NOTES!

The hollow shaft device must slide easily onto the adapter shaft. Never use excessive force, otherwise the bearings may be damaged. If necessary, use emery cloth or a file to produce a better fit between the adapter shaft and the key. Do not allow the device to hit hard against the collar of the shaft.

5. Secure the hollow-shaft device with the aid of the cheese-head screw (6) and a lock washer size 6 (12).
6. Seal installation access.

7. Fastening the torque bracket:

Ideally, the bracket arm (3) should be mounted at an angle of 90° to the link rod (8).

Fastening without base plate:

Secure the link rod head (7) of the link rod (8) to a fixed point (for example on the motor housing).

Fastening with base plate:

Secure the base plate (9) to a fixed point with two hexagon head screws (for example on the motor housing or the foundations).



NOTES!

Once fitted the link rod must rotate easily around the link rod heads! Failure to observe this point may result in damage to the bearings!



NOTES!

The link heads are maintenance free. However, ensure they remain free from soiling and paint!

4.10 Dismantling

4.10.1 Safety instruction

Personnel

Dismantling must be carried out by qualified personnel only.



WARNING!

Observe the safety instructions contained in **Chapter 2** when dismantling the device!



NOTES!

Do not use a hammer or similar tool when installing the device due to the risk of damage occurring to the bearings or coupling!

4.10.2 Dismantling the universal encoder type B5 and B35

To dismantling the universal encoder follow the instructions given in Chapters 4.5 and 4.6 in the reverse order.

4.10.3 Dismantling hollow shaft type

Dismantle the hollow shaft device follow the instructions in Chapter 4.9 in the reverse order.

4.11 Electrical / fiber optic connection and commissioning



NOTES!

You must observe applicable EMC guidelines when routing cables!

4.11.1 Electrical / fiber optic connection

1. Open the terminal box cover (16, Fig. 1:)



CAUTION!

Do not allow moisture to enter the terminal box when the cover is open!

2. Remove the cable gland sealing bolt (17, Fig. 1:)
3. Feed the cable into the terminal box through the cable gland.
4. Tighten the cable gland using a spanner.



NOTES!

Prior to delivery cable glands and blanking plugs are tightened finger tight only. To ensure that the terminal box is reliably sealed tighten all cable glands and blanking plugs before starting up for the first time.

5. Use a spanner to tighten the cable gland until the cable is securely clamped and properly sealed.



NOTES!

Prevent lateral pulling forces acting on the cable and plugs so as not to impair the degree of protection of the cable gland.

6. Connect the supply voltage and fiber optic cables



CAUTION!

Exercise care when operating the actuation rocker of the PCB terminal. Carefully plug in the ST connector paying attention to connector coding!

connection diagram EI 667b

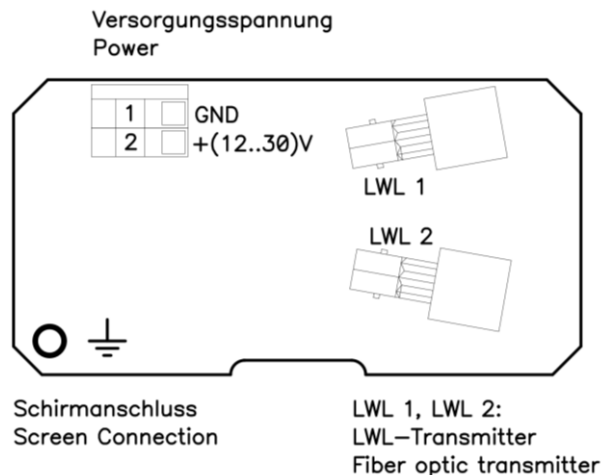

7. Close the terminal box cover.



NOTES!

Before closing the terminal box cover check and if necessary clean both seal surfaces and the gasket.



CAUTION!

Ensure when closing the terminal box cover that no cable becomes jammed.

4.12 Intended use

The basic device UOM 4L-1212 of the Universal Encoder System U-ONE® has been designed and constructed exclusively for the intended use described here.

Claims of any type due to damage arising from non-intended use are excluded; the owner bears sole responsibility for non-intended use.

4.13 Improper use

- Do not use the device in potentially explosive areas.
- The device must not be subjected to mechanical loads in addition to its own weight and unavoidable vibration and shock loads that arise during normal operations.

Examples for non-permitted mechanical loads (incomplete list):

- Fastening transport or lifting tackle to the device, for example a crane hook to lift a motor.
 - Fastening packaging components to the device, for example ratchet straps, tarpaulins etc.
 - Using the device as a step, for example by people to climb onto a motor.
- It is not permitted to use the device in locations higher than 3000 m above sea level.

4.14 Inspections

4.14.1 Safety advice for personnel



WARNING!

Skilled technical staff only are permitted to inspect the device and its installation. Observe the safety instructions contained in **Chapter 2** when inspecting or working on the device!

4.14.2 Maintenance information

The device is maintenance-free. However, to guarantee optimum fault-free operations we recommend that you carry out the following inspections.

Qualified personnel only are permitted to carry out the inspection work described here. In particular, we remind you that you must observe and adhere to all operating and owner-relevant accident prevention regulations, laws regarding the safeguarding of machinery and plant as well as application and country-specific regulations, laws and standards.

4.14.3 Inspection schedule



NOTES!

No interventions other than the cyclic tests described in the test schedule are necessary on the device. Any intervention on the device renders all guarantee claims null and void!

Interval	Inspections
Yearly	Inspect the coupling for damage and absence of play
	Ensure all fastening screws are properly tightened
	Ensure cable connections and connection terminals are properly tightened
	Check the torque bracket (applies to hollow shaft devices only): check link heads can move freely. You must be able to turn the link rod manually. If it proves difficult to move, lightly oil the link rod heads or apply lubricant spray.
Following approx 16 000 – 20 000 hours of operation / higher levels of continuous load	Check deep groove ball bearings for noise, running smoothly. Bearings must be replaced by the manufacturer only.

4.15 Fault table

Fault	Possible cause	Remedy
Moisture in the terminal box	Soiled gasket or seal surfaces of terminal box cover	Clean gasket of terminal box cover and seal surfaces
	Gasket of terminal box cover damaged	Replace gasket of terminal box cover
	Cable gland not tightened	Tighten cable gland
	Unsuitable cable for cable gland	Use suitable cable and cable glands

Contact Hubner-Service (page 2) if none of the actions listed above provide a solution!

5 Replacement parts

The replacement parts listed below can be obtained via the service address on page 2.

Replacement Part	Comment
Cover	Cover for the 2 nd shaft end or for the hollow shaft bore (NDE)
Axial tensioning disk/ring	For hollow shaft design
Cable gland	M20x1,5
Terminal box cover	Including flat seal and screws
Feather key	Specify shaft dimensions or feather key dimensions
Programming cable and software	
Screw plug	To close of the access to the coupling



NOTES!

When ordering replacement parts always specify the serial number of the device!

6 Transport, packaging and storage

6.1 Safety information concerning transport



CAUTION!

Material damage caused by improper transport!

Observe the symbols and information on the packaging:

- Do not throw - risk of breakage
- Keep dry
- Do not expose to heat above 40 °C or direct sunlight.

6.2 Goods inward inspection

Check the delivery immediately upon receipt for transit damage or short delivery.

Inform the carrier immediately on receipt if you determine that damage has occurred during transit (take photos as proof).

6.3 Packaging (disposal)

The packaging is not taken back; dispose of according to the respective valid statutory provisions and local regulations.

6.4 Storing packages (devices)



Keep dry

Keep packages dry and free from dust; protect from moisture.

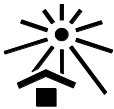

Protect against heat

Protect packages from heat above 40 °C and direct sunlight.

If you intend to store the device for a longer period of time (> 6 months) we recommend you use protective packaging (with desiccant).



NOTES!

Turn the shaft of the device every 6 month to prevent the bearing grease solidifying!

6.5 Returning devices (repairs/goodwill/warranty)

Devices that have come into contact with radioactive radiation or radioactive materials are not taken back.

Decontaminate devices that have may come into contact with harmful chemical or biological substances before returning.

They must also be accompanied by a safety clearance certificate.

6.6 Disposal

The manufacturer is not obliged to take back the device.

The device is classed as electronic equipment and subject to the WEEE Directive; observe local, country-specific laws when disposing of the device.

For information on environmentally sound disposal please contact your local authority or a specialist disposal company.

7 EC-Declaration of Incorporation

	<p style="text-align: center;">EG-Einbauerklärung für unvollständige Maschinen (EG-Richtlinie 2006/42/EG)</p> <p style="text-align: center;">EC-Declaration of Incorporation for partly completed machinery (EC-Directive 2006/42/EC)</p>
<p>Hersteller / Manufacturer: Johannes Hübner Fabrik elektrischer Maschinen GmbH</p>	
<p>Anschrift / Address: 35394 Giessen, Siemensstrasse 7</p>	
<p>Produktbezeichnung / Produkt designation:</p>	
<p>U-One 4L, UO EM-D2, UO-EM-FG4, UO-EM-EGS4, UO-EM-AMC, UO-EM-AMP, UO-EM-AMS, UO-EM-AME/M, UO-EM-ERC</p>	
<p>U-One 4L, UO-EM-D2, UO-EM-FG4, UO-EM-EGS4, UO-EM-AMC, UO-EM-AMP, UO-EM-AMS, UO-EM-AME/M, UO-EM-ERC</p>	
<p>Die oben genannten Produkte entsprechen folgenden grundlegenden Anforderungen der Richtlinie 2006/42/EG:</p>	
<ul style="list-style-type: none"> 1.1.2 Grundsätze für die Integration der Sicherheit 1.1.3 Materialien und Produkte 1.1.5 Konstruktion der Maschine im Hinblick auf Handhabung 1.3.2 Bruchrisiko bei Betrieb 1.3.3 Risiken durch herabfallende oder herausgeschleuderte Gegenstände 1.3.4 Risiken durch Oberflächen, Kanten und Ecken 1.5.1 Elektrische Energieversorgung 1.6.1 Wartung der Maschine 1.7.1 Informationen und Warnhinweise an der Maschine 1.7.2 Warnung vor Restrisiken 1.7.3 Kennzeichnung der Maschinen 	
<p>The above mentioned products meets the following essential requirements from directive 2006/42/EC:</p>	
<ul style="list-style-type: none"> 1.1.2 Principles of safety integration 1.1.3 Materials and products 1.1.5 Design of machinery to facilitate its handling 1.3.2 Risk of break-up during operation 1.3.3 Risks due to falling or ejected objects 1.3.4 Risks due to surfaces, edges or angles 1.5.1 Electricity supply 1.6.1 Machinery maintenance 1.7.1 Information and warnings on the machinery 1.7.2 Warning of residual risks 1.7.3 Marking of machinery 	
<p>Die bezeichneten Produkte stimmen in der von uns in Verkehr gebrachten Ausführung mit den Vorschriften folgender Europäischer Richtlinien überein:</p>	
<p>The products described above in the form as placed on the market are in conformity with the provisions of the following European Directive:</p>	

2014/30/EU (Ausgabe / Version 2014-02-26)
Richtlinie des Europäischen Parlaments und des Rates vom 26. Februar 2014 zur Harmonisierung der Rechtsvorschriften der Mitgliedstaaten über die elektromagnetische Verträglichkeit
Directive 2014/30/EU of the European Parliament and of the Council of 26 February 2014 on the harmonisation of the laws of the Member States relating to electromagnetic compatibility

2006/42/EG: Folgende harmonisierte Normen wurden angewandt:
2006/42/EC: Following harmonised standards have been applied:

DIN EN ISO 12100 (Ausgabe / Version 2013-08)
Sicherheit von Maschinen
Safety of machinery

DIN EN 60204-1 (Ausgabe / Version 2010-05)
Sicherheit von Maschinen – Allgemeine Anforderungen
Safety of machinery – General requirements

2014/30/EU: Folgende harmonisierte Normen wurden angewandt:
2014/30/EU: Following harmonised standards have been applied:

DIN EN 55011 (Ausgabe / Version 2011-04) Industrielle, wissenschaftliche und medizinische Geräte - Funkstörungen - Grenzwerte und Messverfahren
Industrial, scientific and medical equipment - Radio-frequency disturbance characteristics - Limits and methods of measurement

DIN EN 61326-1 (Ausgabe / Version 2013-07)
Elektrische Mess-, Steuer-, Regel- und Laborgeräte - EMV-Anforderungen - Teil 1: Allgemeine Anforderungen
Electrical equipment for measurement, control and laboratory use - EMC requirements -- Part 1: General requirements

Die Erstellung der speziellen technischen Unterlagen nach Anhang VII Teil B wird erklärt. Die Unterlagen werden vom Hersteller auf Verlangen der einzelstaatlichen Stellen zur Verfügung gestellt.

The preparation for relevant technical documents to appendix VII part B is declared. The documents will be made available from manufacturer to request by the competent national authorities.

Die Inbetriebnahme ist so lange untersagt, bis festgestellt wurde, dass - soweit zutreffend - die Maschine, in die o.a. unvollständige Maschine eingebaut werden soll, den Bestimmungen der Maschinenrichtlinie 2006/42/EG entspricht.

Startup is not permitted until it has been determined, that - as applicable - the machine into which the uncompleted machine has to be incorporated, does comply with the requirement of the machine directive (2006/42/EC).

Unterschrift:



Frank Tscherney
(Geschäftsführer / General manager)

Datum: 10.01.2017

Seite 2/2