

CRANE-BOY CRANE-BOYP

CRANE OVERLOAD PROTECTION ELECTRONICS

Crane overload protection electronics with 3 set-points and display



CRANE-BOY CRANE-BOYP

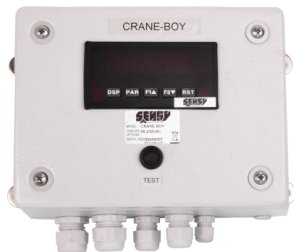

Features

- o Easy and intuitive calibration
- o Display of hoisted load and input signal
- o Internal monitoring system of load cell integrity and load limitation electronics (fail safe)
- o Test button on front cover
- o Also available without industrial metallic housing (see INDI-BOY, DISP-BOYP and DISP-SUMD)

Available option(s)

- Analogue output 4 (0)...20 mA or 0...10 V
- RS-232, RS-485 or fieldbus capabilities
- NEMA 4X / IP65 (transparent protection cover + Option "COVER PAX")
- Power supply: 48 VAC (only for 85...230 VAC version)
- Stainless steel housing

Application(s)

SENSY's CRANE-BOY and CRANE-BOYP are perfectly designed for the following applications:

- Overload protection and slack rope detection of: overhead cranes, container cranes, gantry cranes.

Function(s)

- Internal survey system of the load cell and electronics (fail safe)
- "TEST" button to check the correct working of the detection system
- Secret code prohibiting programming by unauthorised users
- Intelligent filter with quick reaction to overload while not reacting to transitory non-significant overload
- Maximum and minimum memories, smart filter

Specifications	CRANE-BOY	CRANE-BOY24	CRANE-BOYP	CRANE-BOYP24	
Type	Load limiter for single load cell	Load limiter for single load cell	Load limiter for single 4-20 mA load cell	Load limiter for single 4-20 mA load cell	-
Input range	± 24 mVDC / ± 240 mVDC	± 24 mVDC / ± 240 mVDC	20 mA (-2 to +26 mA)	20 mA (-2 to +26 mA)	-
Sensor excitation	10 VDC @ 125 mA max**	10 VDC @ 125 mA max**	24 VDC ± 5 % @ 50 mA max.	24 VDC ± 5 % @ 50 mA max.	-
Display	5 digits (14.2 mm)	5 digits (14.2 mm)	5 digits (14.2 mm)	5 digits (14.2 mm)	-
Accuracy	0.1	0.1	0.1	0.1	% F.S.*
A/D converter	16 bits	16 bits	16 bits	16 bits	-
Converter rate	Up to 20 readings /s	Up to 20 readings /s	Up to 20 readings /s	Up to 20 readings /s	-
Service temperature range	0...+50	0...+50	0...+50	0...+50	°C
Storage temperature range	-40...+60	-40...+60	-40...+60	-40...+60	°C
Power supply	85...250 VAC, 50/60 Hz (15 VA)	11...36 VDC (11 W), 24 VAC (15 VA)	85...250 VAC, 50/60 Hz (15 VA)	11...36 VDC (11 W), 24 VAC (15 VA)	-
Qty of relay	3	3	3	3	-
Relay type	"Form A" - potential free	"Form A" - potential free	"Form A" - potential free	"Form A" - potential free	-
Contact rating	3A @250 VAC / 30VDC	3 A @ 250 VAC / 30 VDC	3 A @ 250 VAC / 30 VDC	3 A @ 250 VAC / 30 VDC	-
IP rating	IP54	IP54	IP54	IP54	-

*F.S. : Full Scale.

** : 5 VDC @ 65 mA max (jumper selectable).

Specifications subject to change without notice.

CRANE-BOY > STANDARD DIMENSIONS

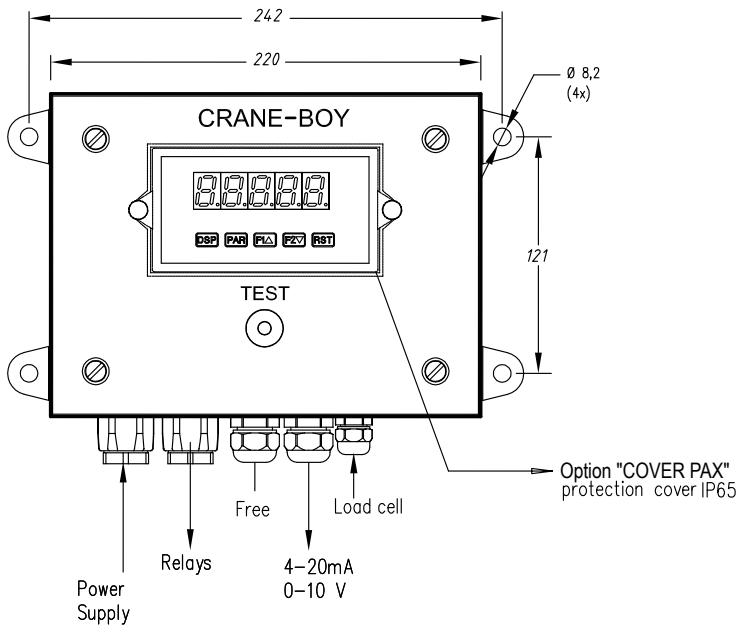
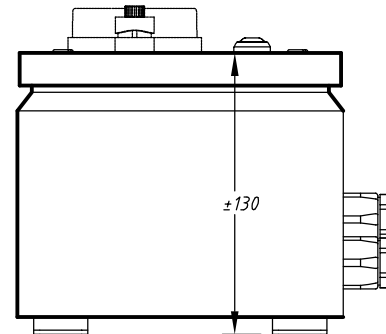
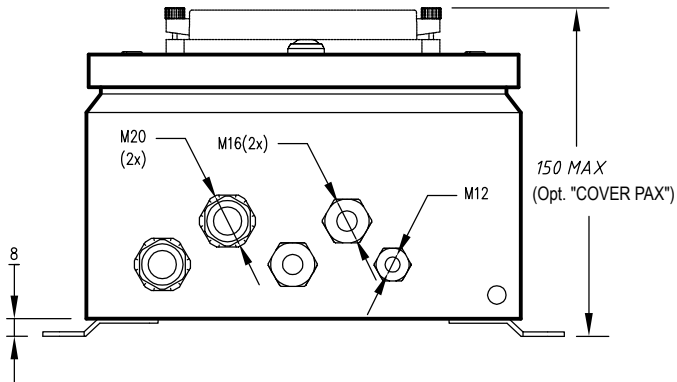

Dimensions in mm

Other views

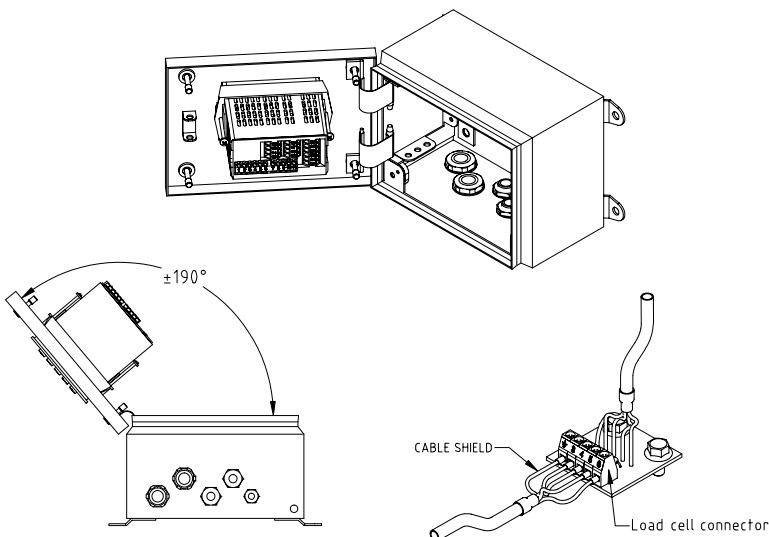

Terminals

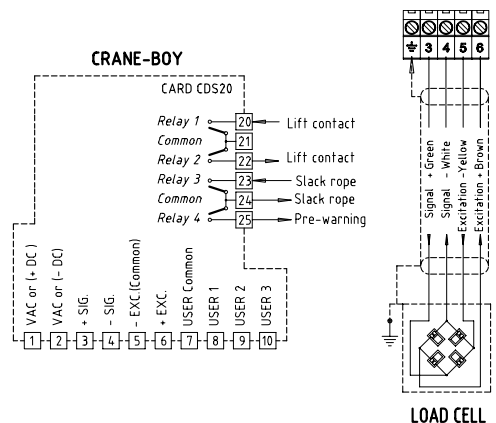

CRANE-BOYP > STANDARD DIMENSIONS

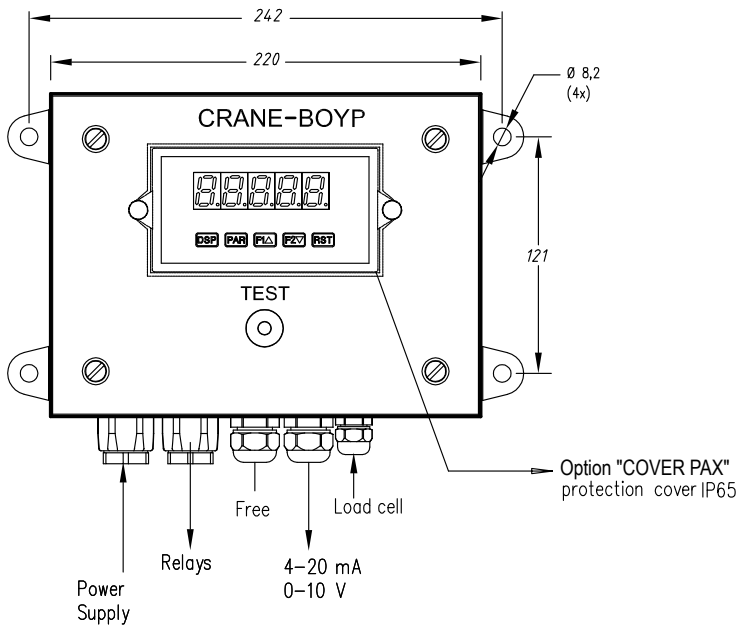
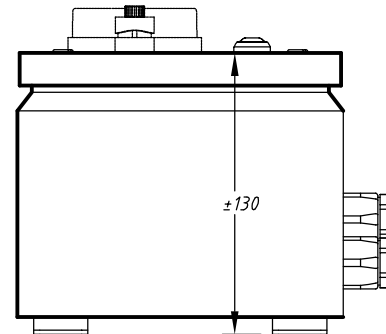
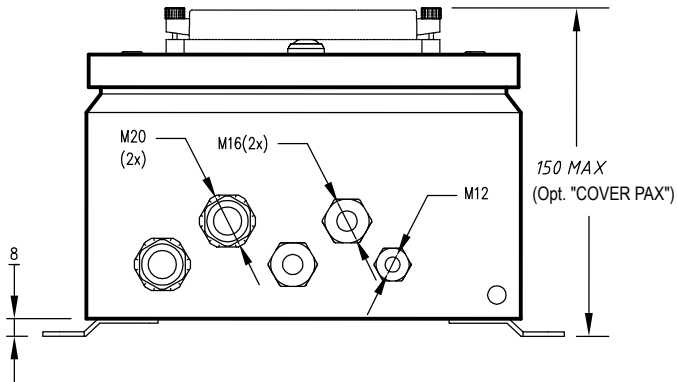

Dimensions in mm

Other views

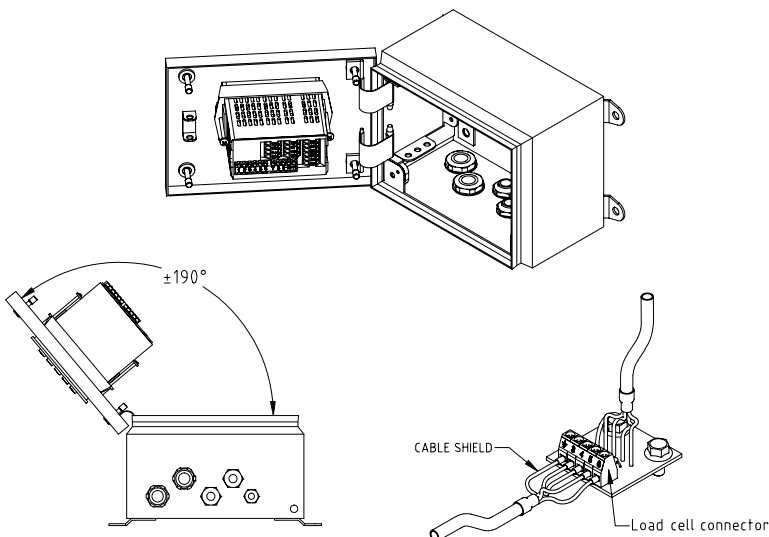

Terminals

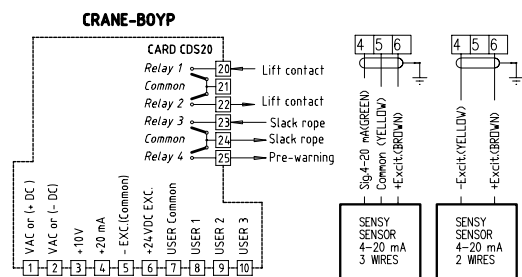

OPTION CARDS

Communication cards (max. 1 choice)

CARD-CDC10

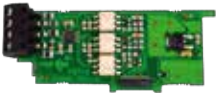

CARD-CDC1C



- RS-485 field bus communication interface
Available with crew terminals or DB9 connector

CARD-CDC10

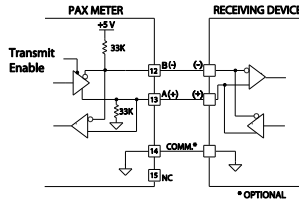

CARD-CDC1C

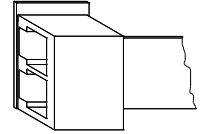
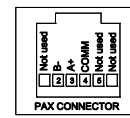

CARD-CDC20

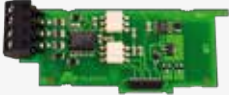

CARD-CDC2C



- RS-232 half-duplex communication interface
Available with crew terminals or DB9 connector

CARD-CDC20

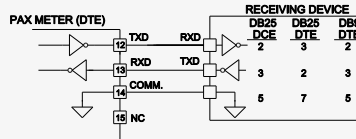

CARD-CDC2C

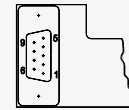

FEMALE
PIN 2 TXD
PIN 3 RXD
PIN 5 COMMON

CARD-CDC30



CARD-CDC40



- DeviceNet communication interface
- Modbus communication interface

CARD-CDC50 / CARD-CDC50-CRANE*



- Profibus-DP (EN 50170) communication interface

* As the CARD-CDC50 is too long for the housing of the CRANE-BOY, the CARD-CDC50-CRANE is supplied with a spacer to be inserted between the front of the electronics and the housing.

Analogue output card

CARD-CDL10



- Analogue output signal: 0-20 mA, 4-20 mA, 0-10 VDC

CARD-CDL10

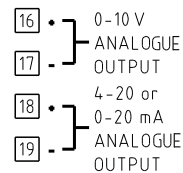

Relay cards (max. 1 choice)

CARD-CDS10 & CARD-CDS20



- 2 or 4 set-points activating each an independent relay

CARD-CDS10

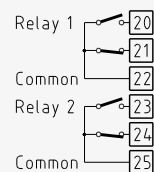

CARD-CDS20

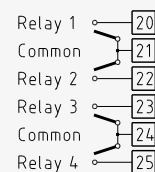

Cards already included

- Analogue output card:

CARD-CDL10

- Relay card:

CARD-CDS20 (4 set-points)

- Models:

CABIN-2xB1SUMD; CABIN-4xB1SUMD

- Models:

INDI-BOY DISP-BOYP; CRANE-BOY CRANE-BOYP; DISP-BOYDP
CRANE-BOYDP; CRANE-SUMD DISP-SUMD; CRANE-BOY-Exd;
CABIN-2xB1SUMD; CABIN-4xB1SUMD.