

NOTES:-  
BEFORE USE READ INSTALLATION SHEET G005-19 FOR FULL INSTRUCTIONS.

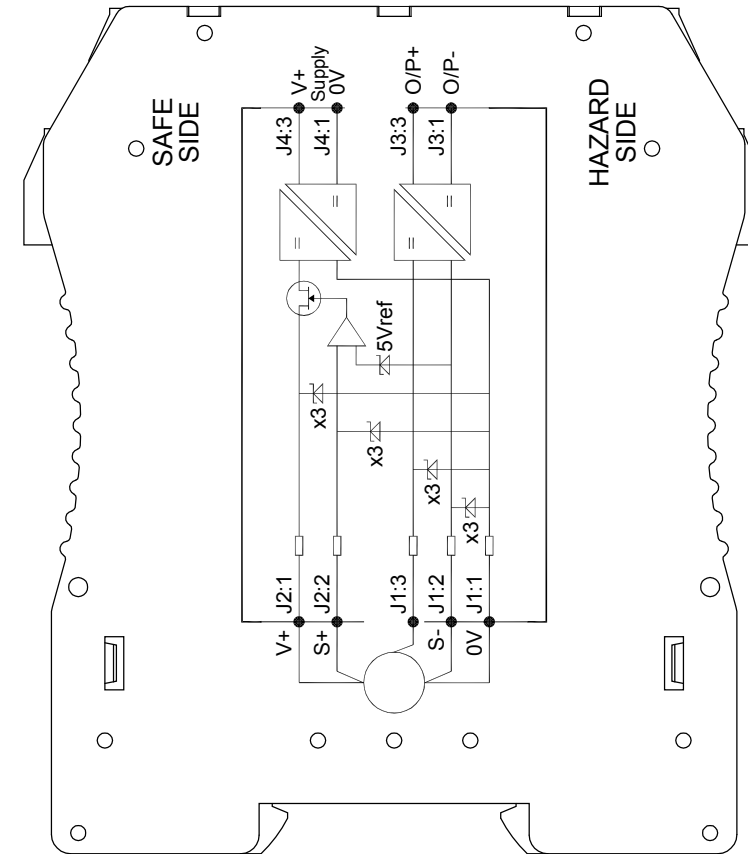

A	FIRST ISSUE.	PDM
B	MARKINGS & HINGE POS'N AMENDED.	PDM
C	NEW CASE OUTLINE RAN 1255	RDS

DRAWINGS NOT TO BE CHANGED WITHOUT REFERENCE TO THE CHANGE PROCEDURE.  
 CHANGES TO PARTS USED IN INTRINSICALLY SAFE PRODUCT MUST BE APPROVED  
 BY THE AUTHORISED PERSON  
 THIS IS AN UNCONTROLLED PRINT AND WILL NOT BE UPDATED.

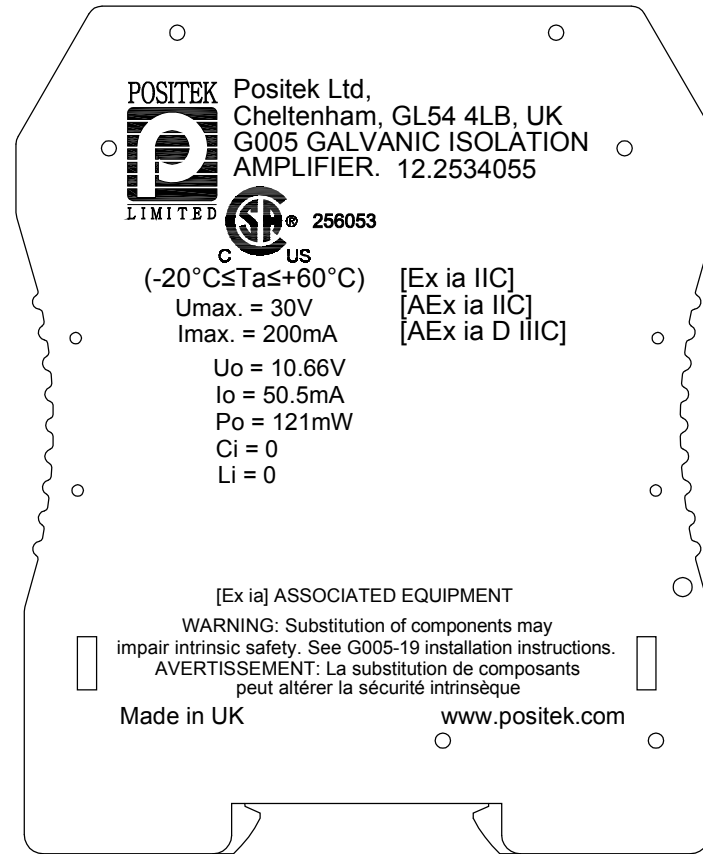
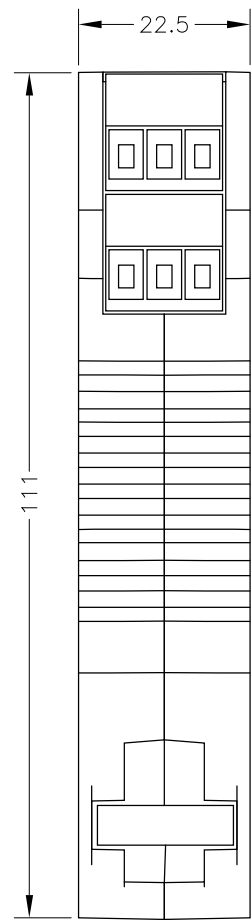
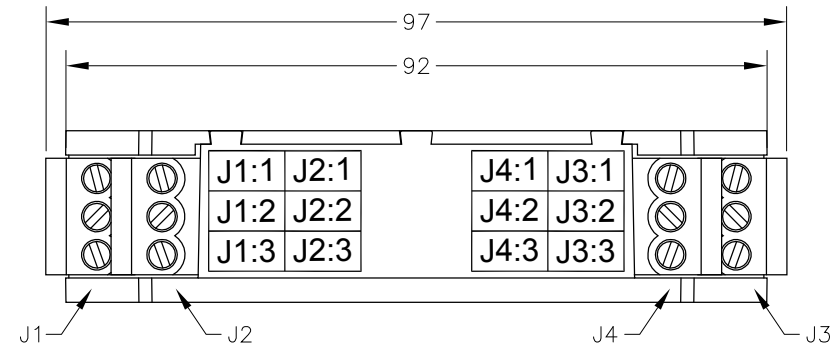
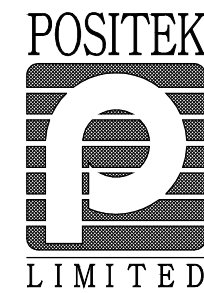

A	21/11/12	CHECKED BY X ±0.4 X.X ±0.2 RDS X.XX ±0.1 DIMS mm
B	28/05/13	
C	31/8/18	
DESCRIPTION		
POSITEK GALVANIC ISOLATION AMPLIFIER CSA APPROVAL		
SCALE	DRAWING NUMBER	REV
10mm	G005-11	C
	SHEET	OF
	1	1

# G005 GALVANIC ISOLATION AMPLIFIER FOR INTRINSICALLY SAFE SENSORS IN HAZARDOUS ATMOSPHERES

- Certified [Ex ia IIC] [AEx ia IIC]  
 [AEx iaD IIIC]
- Super fast 4.7kHz (-3dB) bandwidth
- Wide power supply range
- Voltage and current output options
- Three or Five wire mode connection



The G005 Galvanic Isolation Amplifier has been designed specifically for use with Positek® Intrinsic Safe position sensors in hazardous Zone 0, 20 Class I, II & III applications and is certified; [Ex ia IIC] [AEx ia IIC] [AEx iaD IIIC].

Positek® IS sensors are ratiometric i.e. the output signal scales with the supply voltage, to ensure the safe area signal accurately corresponds with sensor displacement it is important that the sensor supply is correct.

The G005 Galvanic Isolation Amplifier provides a regulated and resistively limited +5V dc power supply required by Positek® IS sensors, it can be connected in three or five wire modes. Used in five wire mode positive and negative sense inputs enable the G005 to dynamically adjust the sensor supply thus ensuring the correct voltage across the sensor. Connected in this way the G005 can compensate for 15Ω conductor resistance. The sense terminals are linked internally so the end user can use the G005 in three wire or five wire mode without the need to fit or remove external links.

The G005 has an input power supply range of 12 to 30 volts dc, making it suitable for a wide range of hazardous area applications. It is tri-port isolated providing isolation between the amplifier power supply, the hazardous area and the G005 output signal. The sensor supply and output are transformer coupled providing 2.5kV isolation between the safe and hazardous area circuits eliminating the requirement for a high-integrity earth.

The output of the G005 is factory configured to either 0.5 to 9.5V or 4-20mA and has a bandwidth of 4.7kHz, making it ideal for servo control loops.

Output options available;

G005-545	0.5 to 9.5V
G005-546	9.5 to 0.5V
G005-425	4 to 20mA
G005-426	20 to 4mA

Versions are also available for potentiometer inputs.

The screw terminal connector plugs are coded to eliminate cross connection.

## Specification

<b>Power Supply</b>	(J4 pins 1 (0V) and 3 (+V))
Voltage:	24V dc Nom. 12V - 30V
Current consumption (24V supply)	approx. 50mA [Voltage O/P] approx. 70mA [Current O/P]
<b>Input Circuit</b>	(J1 pins 1,2,3 & J2 pins 1 & 2)
<b>Intrinsic Safety</b>	Transformer isolated
	[Ex ia IIC] Ta = -20°C ≤ Ta ≤ +60°C [AEx ia IIC] Ta = -20°C ≤ Ta ≤ +60°C [AEx iaD IIIC] Ta = -20°C ≤ Ta ≤ +60°C
<b>Safety Parameters</b>	
Uo: 10.66V Io: 50.5mA Po: 121mW Li: 0 Ci: 0 Um: 253 V	
Sensor supply:	5V @15mA max.
Lead resistance compensation:	15Ω maximum (15mA) all connections
Input resistance (J1 pin 3)	>5MΩ
<b>Output Circuit</b>	(J3 pins 1 {O/P-} and 3 {O/P+})
Voltage	0.5 to 9.5V
Output resistance	5Ω
Current loop	4 to 20mA
Load resistance	0 - 1kΩ
<b>Transfer Characteristics</b>	
Non-linearity:	< ± 0.1% FS
Temperature drift:	< 0.01% FS/°C for voltage outputs
Settling time to 1% of span:	< 300µs for 10-90% step change
Rise time:	< 200µs 10-90% of step change
Bandwidth	dc to 4.7kHz (-3dB)
Isolation:	2500V between safe area terminals and hazardous area terminals, 50V between power rail (J4) and output (J3)
<b>Electromagnetic Compatibility</b>	EN561236-2-1:2006 (EN31326-1:2006)
Ambient temperature range:	-20° to 60°C working -40°C to +100°C storage
Housing:	97.3 mm x 22.5 mm x 111.9 mm
Protection class:	IP20
Mounting:	35x7.5 mm top-hat rail (DIN 46277-3)
Connector Conductor Size:	0.2 to 2.5mm <sup>2</sup> (26-12 AWG)
Weight:	120g approx.

For further information please contact:

www.positek.com sales@positek.com

Tel: +44(0)1242 820027 fax: +44(0)1242 820615

Positek Ltd, Andoversford Industrial Estate, Cheltenham GL54 4LB U.K.



G005-17b

# Three or Five-Wire Mode Connection FOR INTRINSICALLY SAFE SENSORS IN HAZARDOUS ATMOSPHERES

The aim of this document is to help readers who do not understand what is meant by three or five wire modes of connection between the galvanic isolation amplifier and sensor, and the factors behind them. It is by no means an in-depth technical analysis of the subject.

Whether opting for a pre-wired Positek® Intrinsically Safe sensor or one with a connector, choosing the right mode of connection and cable to suit the application requires careful consideration.

Interconnecting cables are not perfect conductors and offer resistance to current flow, the magnitude of resistance<sup>†</sup> depends on conductors resistivity, which changes with temperature, cross sectional area<sup>‡</sup> and length. If the voltage were to be measured at both ends of a length of wire it would be found they are different, this is known as volts drop. Volts drop changes with current flow and can be calculated using Ohm's law, it should be noted that volts drop occurs in both positive and negative conductors. The effects of volts drop can be reduced by increasing the conductors cross sectional area, this does not however eliminate the effects due to temperature variation. There are instances where large cross-section cables are not practical; for example most standard industrial connectors of the type used for sensors have a maximum conductor capacity of 0.75mm<sup>2</sup>, copper prices and ease of installation are other considerations.

This is important because the effects of volts drop can significantly alter the perceived accuracy of the sensor which is ratiometric i.e. the output signal is directly affected by the voltage across the sensor. Changes in temperature will also be seen as gain variation in the sensor output.

**Three wire mode** connections are common and are suitable in most cases with short or moderate cable runs. Applications that do not require a high degree of accuracy but have cable runs, say in excess of 10m, volts drop can be reduced by introducing a terminal box close to the sensor and using a larger cross-section cable for a majority of the cable run. Sensors supplied with three core cable are calibrated with the cable fitted which largely eliminates errors due to conductor resistance at room temperature however, as mentioned above, small gain errors due to temperature fluctuations should be expected.

**Five wire mode** connections have significant benefits as losses in the positive and negative conductors are compensated for by the galvanic isolation amplifier which can 'sense' the voltage across the sensor and dynamically adjust the output voltage so that the voltage across the sensor is correct. The effects of cable resistance and associated temperature coefficients are eliminated allowing for smaller conductors than a three wire connection for the same cable run. The amplifier can compensate for up to 15Ω per conductor with a current flow of 15mA, which is more than adequate for 150m of 0.25 mm<sup>2</sup> cable, longer lengths will require larger conductors.

**For this reason Positek® recommends five wire connections for cable lengths exceeding 10 metres in 0.25 mm<sup>2</sup> cable to preserve the full accuracy of the sensor.**

See illustrations below for examples of connecting a sensor to the galvanic isolation amplifier.

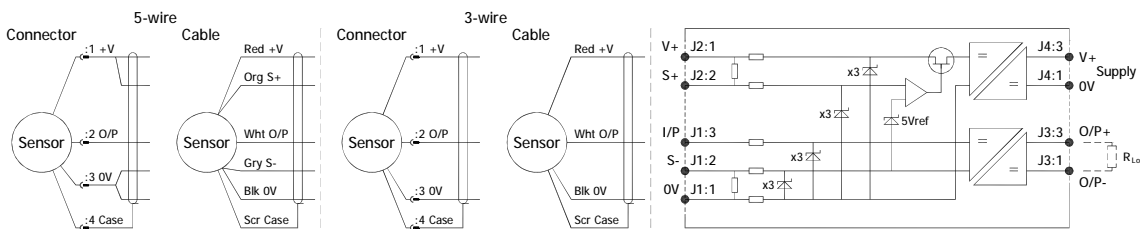

Cable Length (metres)	Up to 150	150 - 300	300 - 450	450 - 600	600 - 900	900 - 1000
Cross Section (mm <sup>2</sup> )	0.25	0.5	0.75	1.0	1.5	2.0

The table above shows recommended conductor sizes with respect to cable length for both three and five wire connections, based on copper conductors. Three wire connections will introduce a gain reduction of 5% and a ±1% temperature dependence of gain over the range -40°C to +80°C for the cable temperature. (i.e. about -150 ppm/°C for the maximum lengths shown and less pro rata for shorter lengths.)

It should be noted that the maximum cable length, as specified in the sensor certification, takes precedence and must not be exceeded.

Positek® sensors are supplied with three core 0.25 mm<sup>2</sup> cable as standard, however five core 0.25 mm<sup>2</sup> cable can be supplied on request. The galvanic isolation amplifier is available as;

- G005-\*\*\* for 'G' and 'H' prefix sensors
- X005-\*\*\* for 'E', 'M' and 'X' prefix sensors

<sup>†</sup>  $R = \rho L/A$   $\rho$  is the resistivity of the conductor ( $\Omega m$ )  $L$  is the length of conductor (m)  $A$  is the conductor cross-sectional area (m<sup>2</sup>).

<sup>‡</sup> It is presumed that direct current flow is uniform across the cross-section of the wire, the galvanic isolation amplifier and sensor are a dc system.

# Installation Information

## G005 Galvanic Isolation Amplifier

### INTRINSICALLY SAFE FOR HAZARDOUS ATMOSPHERES

CSA Qualified Associate Apparatus for Category 'ia' Certificate number CSA 12.2534055				[Ex ia IIC] Ta = -20°C ≤ Ta ≤ +60°C [AEx ia IIC] Ta = -20°C ≤ Ta ≤ +60°C [AEx ia D IIC] Ta = -20°C ≤ Ta ≤ +60°C	
Base Part N°	Module Supply Voltage:	Module Supply Current:	Sensor Supply Voltage	Sensor Supply Current	Conductor Resistance Compensation
G005-	24V Nom. (12-30V)	200mA Max. 50mA Voltage O/P (Nom.) 70mA Current O/P (Nom.)	5V nom.	15mA max.	15Ω five wire mode
Option Code	Output Signal	Calibration	Comments		
545	0.5 to 9.5V	Standard Output	For Positek Z000 coded sensors		
546	9.5 to 0.5V	Reverse Output			
425	4 to 20mA	Standard Output			
426	20 to 4mA	Reverse Output			
010	0.5 to 9.5V	Standard Output	For Positek sensors previously manufactured for use with BX002 i.e. Z010 Note: X005 does not have the same pin connections as BX002		
420	4 to 20mA	Standard Output	For Positek sensors previously manufactured for use with BX003 i.e. Z420 Note: X005 does not have the same pin connections as BX003		
001	0.5 to 9.5V	Standard Output	For Potentiometers		
002	9.5 to 0.5V	Reverse Output			
003	4 to 20mA	Standard Output			
004	20 to 4mA	Reverse Output			

**Putting Into Service:** This module must only be installed, operated and maintained by competent and suitably trained personnel. The installation and maintenance must be carried out in accordance with all appropriate international, national and local standard codes of practice and site regulations for intrinsically safe apparatus.

**Safety parameters:-**

Um	=	253V	connector J4 pin 3 with respect to pin1		
Uo	=	10.66V	connectors J1 and J2 pins 1 and 2 with respect to J1 pin 1		
Io	=	50.5mA			
Po	=	121mW			
	Group	IIC	IIB	IIA	
Co	=	2.23µF	15.6µF	69.0µF	
Lo	=	14mH	53mH	112mH	
or L/R Ratio	=	295µH/Ω	1178µH/Ω	2357µH/Ω	
Ci	=	0µF			
Li	=	0mH			

**Use:** The G005 Galvanic Isolation Amplifier is designed to supply a sensor, operating in hazardous environment, with an isolated and resistively limited dc supply and also isolate and amplify the sensor output for transmission in the safe area. This module has been designed to meet the requirements of Associate Apparatus for Category 'ia'.

**Maintenance:** This module **must not** be installed in a position where;

It may be exposed to excessive accumulation of dust.

It may be attacked by aggressive substances.

It may be subjected to mechanical or thermal stresses in excess of those permitted in the certification documentation.

Access to the circuitry **must not** be made during operation.

This module **cannot** be repaired by the user and **must** be replaced by another suitably certified part. Repairs can only be carried out by the manufacturer or approved repairer.

**Mechanical Mounting:** The housing is designed to be mounted on 35x7.5 mm top-hat rail (DIN 46277-3). It is recommended that this module is mounted inside a suitable enclosure.

This module **must not** be installed in the hazardous area **without** the further provision of certified hazardous area protection.

**Electrical Connections:** The screw terminal connector blocks can be removed to simplify panel wiring or replacement of a damaged module. The connector blocks are key coded to reduce the chance of cross connection and can accommodate conductors with a cross section of 0.2 to 2.5mm<sup>2</sup> (26-12 AWG).



For further information please contact:  
 www.positek.com sales@positek.com  
 Tel: +44(0)1242 820027 fax: +44(0)1242 820615  
 Positek Ltd, Andoversford Industrial Estate, Cheltenham GL54 4LB. U.K.



G005-19c

# Installation Information

## G005 Galvanic Isolation Amplifier

### INTRINSICALLY SAFE FOR HAZARDOUS ATMOSPHERES

This module has been designed to drive a sensor, or potentiometer, in either three or five wire mode.

In three wire mode conductor resistance is not compensated, which can result in perceived inaccuracies due to volts drop down the cable. Increasing conductor cross section reduces some of the effects of conductor resistance.

In five wire mode up to 15Ω resistance in each conductor can be compensated for, while providing the sensor with a current of 15mA. This mode is recommended for all applications requiring high degrees of accuracy and / or where the cable length between module and sensor is greater than 10 metres.

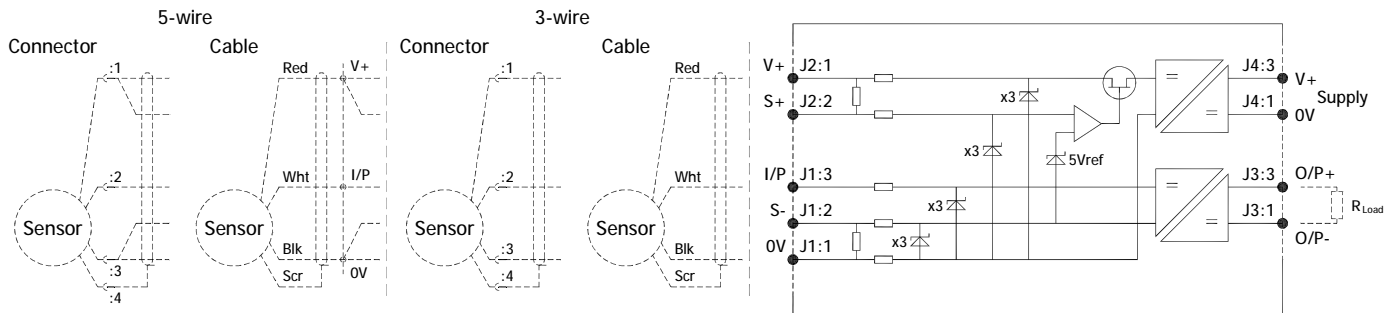

To ensure correct operation of both Amplifier and sensor, the following restrictions on conductor cross section and cable length limits are set out below (figures are based on copper conductors);

Cross Section (mm <sup>2</sup> )	Cable Length (metres)
0.25	Up to 150
0.5	150 to 300
0.75	300 to 450
1.0	450 to 600
1.5	600 to 900
2.0	900 to 1000

**Output Characteristic:** The safe area output changes with respect to the hazardous area input, direction is dependant on selected version. Voltage or 4-20mA loop output options are available.

**Incorrect Connection Protection Levels:** Safe area connections are reverse polarity protected.